

# SWIMMING POOL HEAT PUMP

## User and Service Manual





## INDEX FOR DIFFERENT LANGUAGES

Bedienungsanleitung Deutsch	P2 - P48
English manual	P40 - P92
Manuel français	P93 - P139
Manuale italiano	P140 - P187
Manual en español	P188 - P237
Instruction of WIFI connection	P238 - P244

# **SCHWIMMBAD-WÄRMEPUMPE**

**Benutzer- und Wartungshandbuch**

**INVERBOOST INVERTER**

# Verordnung (EU) Nr. 517/2014 vom 16/04/14 über fluorierte Treibhausgase und die Verordnung (EG) zur Aufhebung Nr. 842/2006

---

## Dichtheitsprüfung

1. Die Betreiber von den Geräte, die die fluorierte Treibhausgase in Mengen von 5 Tonnen CO<sub>2</sub>-Äquivalent oder mehr enthalten und nicht in Schäumen enthalten, müssen sicherstellen, dass das Gerät auf Dichtheit überprüft wird.
2. Für die Geräte, die fluorierte Treibhausgase in Mengen von 5 Tonnen 5 Tonnen CO<sub>2</sub>-Äquivalent oder mehr enthalten aber weniger als 50 Tonnen CO<sub>2</sub>-Äquivalent enthalten: mindestens alle 12 Monate.

## Bild der Gleichwertigkeit CO<sub>2</sub>

1. Belastung von CO<sub>2</sub> in kg und Tonnen.

Belastung und Tonnen von CO <sub>2</sub>	Häufigkeit der Prüfung
Von 7 bei 75 kg Belastung = von 5 bei 50 Tonnen	Jedes Jahr

**In Bezug auf die Gaz R32, 7,40 kg in Höhe von 5 Tonnen CO<sub>2</sub>, Engagement für die Überprüfung jedes Jahr.**

## Ausbildung und Zertifizierung

1. Die Betreiber der betreffenden Anwendung sollen dafür Sorge tragen, dass die zuständige Person die erforderliche Zertifizierung erlangt hat, die die angemessene Kenntnisse der geltenden Vorschriften und Normen sowie die notwendige Kompetenz in Bezug auf die Emissionsvermeidung und -verwertung von fluorierten Treibhausgasen und der Handhabungssicherheit der betreffenden Typen und Größe der Ausrüstung beinhaltet.

## Aufbewahrung der Aufzeichnungen

1. Die Betreiber von den Geräte, die auf Dichtheit überprüft werden müssen, müssen für jedes Gerät, das die folgenden Angaben enthält, Aufzeichnungen erstellen und verwalten:
  - a) Die Menge und Art der installierten fluorierten Treibhausgase;
  - b) Die Mengen an fluorierten Treibhausgasen, die während der Installation, Wartung oder Service oder aufgrund von Leckagen hinzugefügt werden;
  - c) Ob die Mengen der installierten fluorierten Treibhausgase wiederverwandt oder zurückgefordert wurden, einschließlich der Name und Anschrift der Wiederverwendung oder Rückgewinnungsanlage und gegebenenfalls der Bescheinigungsnummer;
  - d) Die Menge der fluorierten Treibhausgase wiederhergestellt wird;
  - e) Die Identität des Unternehmens, das die Ausrüstung installiert, gewartet und gegebenenfalls repariert oder außer Betrieb hat, gegebenenfalls einschließlich der Nummer des Zertifikats;
  - f) Datum und Ergebnisse der Prüfung durchgeführt werden;
  - g) Wenn das Gerät außer Betrieb hat, wurden die Maßnahmen zur Rückgewinnung und Beseitigung der fluorierten Treibhausgase getroffen.
2. **Die Betreiber bewahrendie Aufzeichnungen für mindestens fünf Jahre lang auf, wobei die Unternehmen, die die Tätigkeiten für die Betreiber ausführen, die Aufzeichnungen für mindestens fünf Jahre lang aufbewahren soll.**

# INDEX

1. Spezifikation
2. Abmessung
3. Standort und Verbindung
4. Den Bypass einstellen
5. Bedienung des Steuergeräts
6. Fehlerbehebung
7. Elektronische Verkabelung
8. Wartung
9. Explosionszeichnung

Danke dass Sie INVERBOOST INVERTER für das Beheizen ihres Schwimmbeckens benutzen. Es wird ihr Poolwasser aufheizen und auf einer konstanten Temperatur halten, wenn die Außentemperatur zwischen -20 und 43 °C liegt.



**ACHTUNG: Dieses Handbuch beinhaltet alle Informationen die für die Benutzung und die Installation ihrer Wärmepumpe erforderlich sind.**

Der Installateur muss das Handbuch gründlich durchlesen und den Anweisungen strikt folgen, sowohl bei der Implementierung als auch bei der Wartung.

Der Installateur ist verantwortlich für die Installation des Produkts und sollte allen Anweisungen des Herstellers sowie allen Vorschriften in den Anwendungen folgen. Inkorrekte Installation gegen die Anweisungen des Handbuchs macht die Garantie nichtig.

Der Hersteller lehnt jede Verantwortung ab für Schäden die durch Menschen, Objekte oder Fehler die auf Nichtbefolgung von Anweisungen im Handbuch beruhen. Jede Nutzung die bei der Herstellung nicht vorgesehen war wird als gefährlich eingestuft.

**WARNUNG:** Bitte leeren Sie das Wasser in der Wärmepumpe im Winter oder wenn die Temperatur unter 0°C sinkt, sonst wird der Titanium-Wechsler durch Frost beschädigt. In diesem Fall ist die Garantie nichtig.

**WARNUNG:** Bitte schalten Sie immer die Stromversorgung aus, wenn sie die Kabine öffnen wollen um ins Innere der Wärmepumpe vorzudringen, da drinnen Hochspannung herrscht.

**WARNUNG:** Bitte bewahren Sie den Kontrolldisplay an einem trockenen Ort, oder schließen Sie die Isolationsabdeckung sorgfältig, um es vor Beschädigung durch Nässe zu schützen.

# 1. Spezifikation

## Technische Daten INVERBOOST INVERTER Pool Wärmepumpen

Modell		UX11Csi32	UX14Csi32	UX17Csi32
<b>* Leistung bei Luft 28°C, Wasser 28°C, Luftfeuchtigkeit 80 %</b>				
Turbo Heizleistung	kW	11.0	14.0	17.0
Smart Heizleistung	kW	10.0	11.0	14.0
Energieverbrauch	kW	1.55-0.17	1.97-0.22	2.39-0.27
C.O.P.		16-7.4	16-7.1	16-7.2
C.O.P. in Turbo		7.4	7.1	7.2
C.O.P. at 50% capazität		11.8	11.0	11.8
<b>* Leistung bei Luft 15°C, Wasser 26°C, Luftfeuchtigkeit 70 %</b>				
Turbo Heizleistung	kW	8.5	9.5	12.0
Smart Heizleistung	kW	7.0	8.0	10.5
Energieverbrauch	kW	1.67-0.26	1.90-0.29	2.31-0.37
C.O.P.		8.2-5.1	8.21-5	8.5-5.2
C.O.P. in Turbo		5.1	5.0	5.2
C.O.P. at 50% capazität		7.1	7.0	7.8
<b>* Allgemeine Daten</b>				
Kompressortyp		Wechselrichterkompressor		
Spannung		220-240V/50Hz/1PH		
Nennstrom	A	6.9	8.7	10.6
maximale Spannung	A	10.5	13.5	15.5
Minimale Sicherung	A	12.0	15.0	16.0
Empfohlener Wasserfluss	m <sup>3</sup> /h	3.7	4.0	5.0
Wasserdruckabfall	Kpa	12.0	14.0	15.0
Wärmetauscher		Twist-Titan-Rohr aus		
Wasserverbindung	mm	50		
Anzahl der Lüfter		1		
Belüftungsart		Horizontal		
Geräuschpegel (10 m)	dB(A)	17.8-26.2	21.7-26.7	22.6-28.1
Geräuschpegel (1 m)	dB(A)	36-46.2	38-47.6	39.5-49.8
<b>* Abmessungen/Gewicht</b>				
Nettogewicht	kg	73	78	98
Bruttogewicht	kg	78	83	113
Netto-Abmessungen	mm	1028*441*685	1028*441*685	1073*492*886
Verpackungsmaße	mm	1140*500*830	1140*500*830	1185*530*1030

Modell		UX21Csi32	UX26Csi32	UX30Csi32
<b>* Leistung bei Luft 28°C, Wasser 28°C, Luftfeuchtigkeit 80 %</b>				
Turbo Heizleistung	kW	21.0	26.0	30.0
Smart Heizleistung	kW	18.0	21.0	25.0
Energieverbrauch	kW	2.96-0.33	3.66-0.29	4.17-0.47
C.O.P.		16-7.1	16-7.1	16-7.1
C.O.P. in Turbo		7.1	7.1	7.1
C.O.P. at 50% capazität		11.2	11.2	11.2
<b>* Leistung bei Luft 15°C, Wasser 26°C, Luftfeuchtigkeit 70 %</b>				
Turbo Heizleistung	kW	15.5	18.0	20.0
Smart Heizleistung	kW	13.5	16.0	18.0
Energieverbrauch	kW	3.04-0.47	3.53-0.55	3.92-0.61
C.O.P.		8.3-5.1	8.2-5.1	8.2-5.1
C.O.P. in Turbo		5.1	5.1	5.1
C.O.P. at 50% capazität		7.4	7.2	7.2
<b>* Allgemeine Daten</b>				
Kompressortyp		Wechselrichterkompressor		
Spannung		220-240V/50Hz/1PH		
Nennstrom	A	13.1	16.3	18.5
maximale Spannung	A	19.5	24.0	28.0
Minimale Sicherung	A	22	28	32
Empfohlener Wasserfluss	m³/h	6.0	8.0	10.0
Wasserdruckabfall	Kpa	15	18	20
Wärmetauscher		Twist-Titan-Rohr aus		
Wasser Verbindung	mm	50		
Anzahl der Lüfter		1	2	2
Belüftungsart		Horizontal		
Geräuschpegel (10 m)	dB(A)	22.9-30.6	23.1-31.8	23.2-32.4
Geräuschpegel (1 m)	dB(A)	40-51	41-51.6	42-51.8
<b>* Abmessungen/Gewicht</b>				
Nettogewicht	kg	117	125	130
Bruttogewicht	kg	135	145	148
Netto-Abmessungen	mm	1073*492*886	1039*509*1289	1113*519*1410
Verpackungsmaße	mm	1185*530*1030	1185*565*1435	1225*540*1555



Modell		UX30Csi32T	UX35Csi32T
<b>* Leistung bei Luft 28°C, Wasser 28°C, Luftfeuchtigkeit 80 %</b>			
Turbo Heizleistung	kW	30.0	35.0
Smart Heizleistung	kW	25.0	30.0
Energieverbrauch	kW	4.17-0.47	4.93-0.55
C.O.P.		16-7.1	16-7.1
C.O.P. in Turbo		7.1	7.1
C.O.P. at 50% capazität		11.2	11.2
<b>* Leistung bei Luft 15°C, Wasser 26°C, Luftfeuchtigkeit 70 %</b>			
Turbo Heizleistung	kW	20.0	24.0
Smart Heizleistung	kW	18.0	22.0
Energieverbrauch	kW	3.85-0.61	4.62-0.73
C.O.P.		8.2-5.2	8.2-5.2
C.O.P. in Turbo		5.2	5.2
C.O.P. at 50% capazität		7.2	7.2
<b>* Allgemeine Daten</b>			
Kompressortyp		Wechselrichterkompressor	
Spannung		380V/50Hz/3PH	
Nennstrom	A	7.5	8.8
maximale Spannung	A	12.0	14.0
Minimale Sicherung	A	15	17
Empfohlener Wasserfluss	m³/h	10.0	15.0
Wasserdruckabfall	Kpa	20	25
Wärmetauscher		Twist-Titan-Rohr aus	
Wasserverbindung	mm	50	
Anzahl der Lüfter		2	2
Belüftungsart		Horizontal	
Geräuschpegel (10 m)	dB(A)	23.2-32.4	23.4-32.8
Geräuschpegel (1 m)	dB(A)	42-51.8	42.8-52
<b>* Abmessungen/Gewicht</b>			
Nettogewicht	kg	130	135
Bruttogewicht	kg	148	150
Netto-Abmessungen	mm	1113*519*1410	1113*519*1410
Verpackungsmaße	mm	1225*540*1555	1225*540*1555

\*Oben genannten Daten sind Themen, die ohne vorherige Ankündigung zur Änderungen.

## 2. Abmessung

UX11Csi32/UX14Csi32

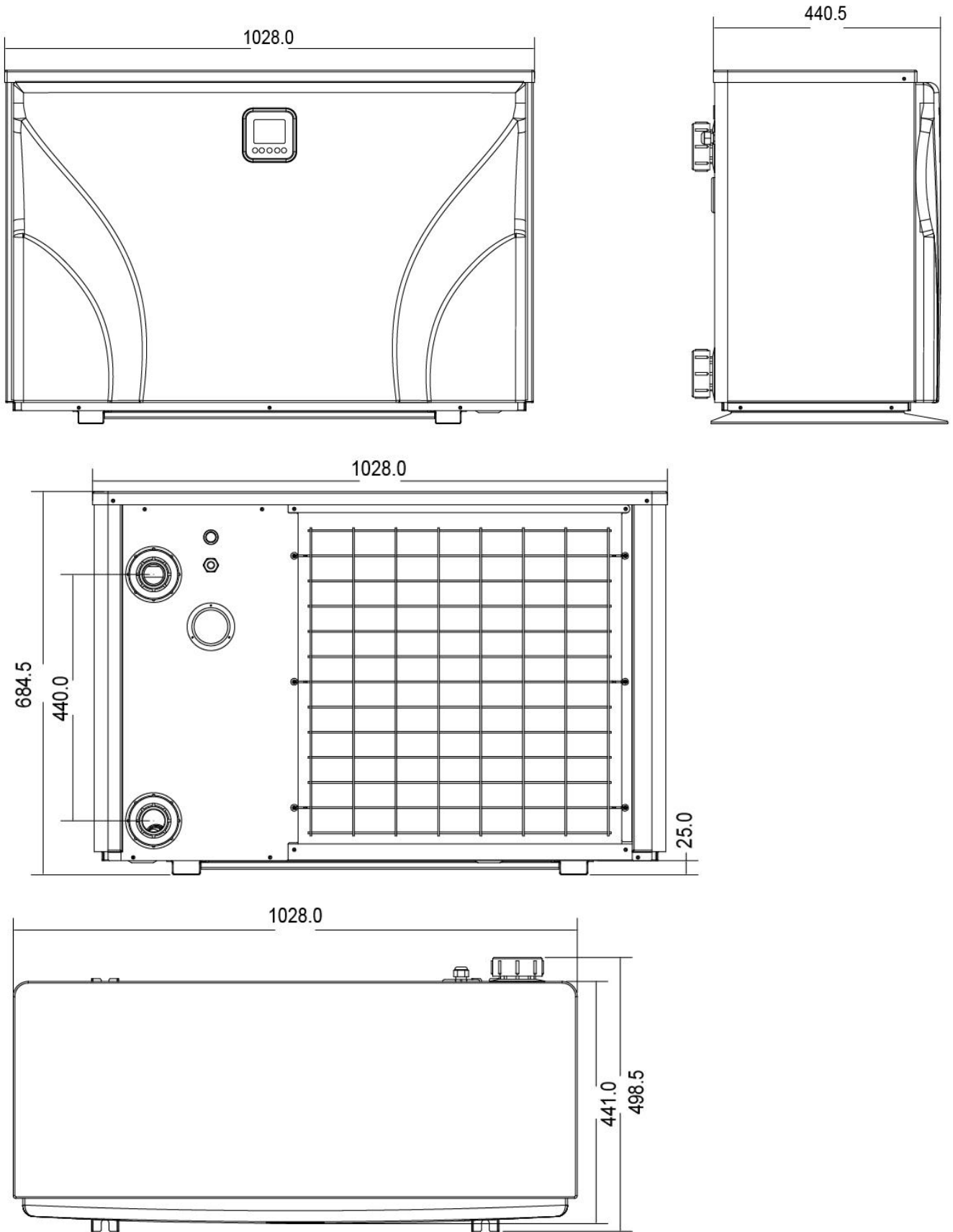

UX17Csi32/UX21Csi32

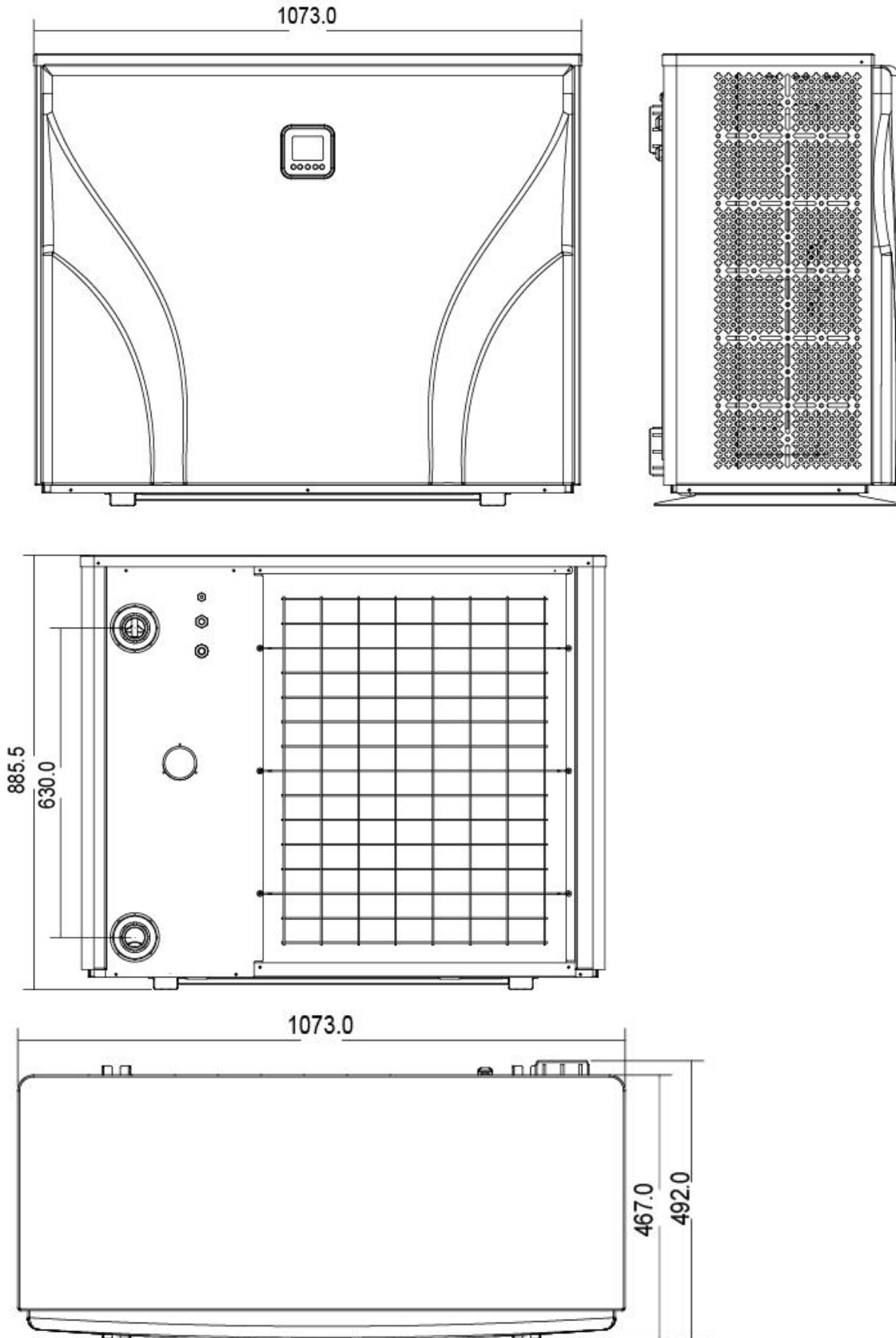

UX26Csi32

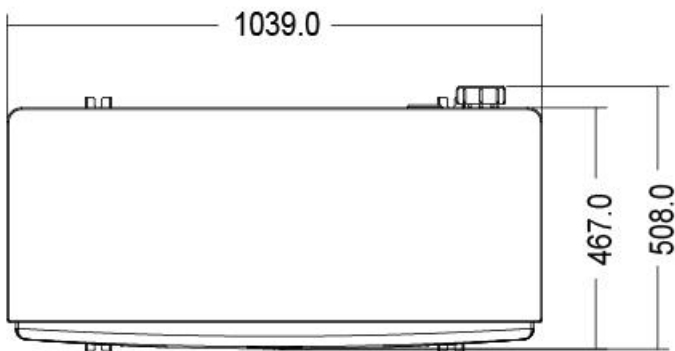
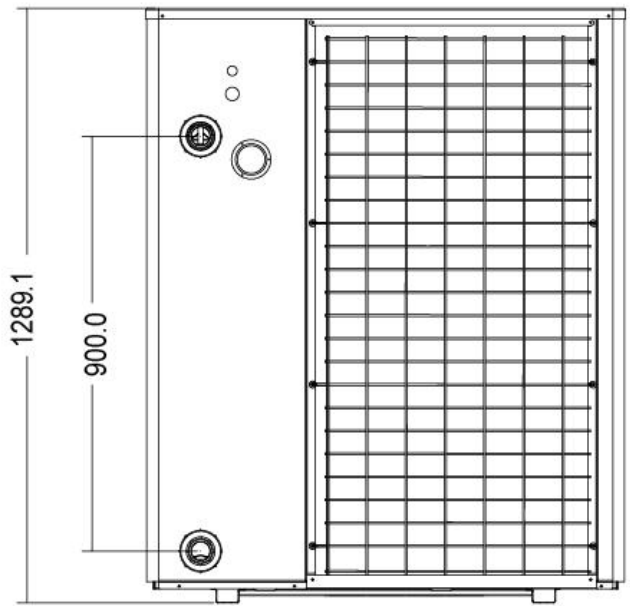
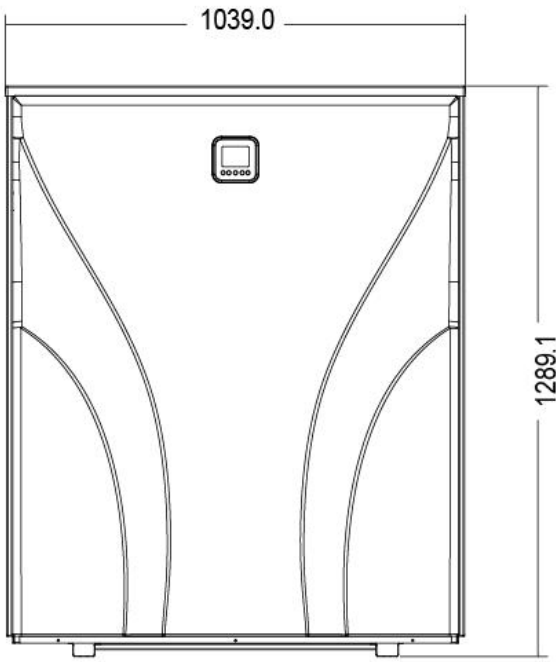

UX30Csi32/UX30Csi32T/UX35Csi32T

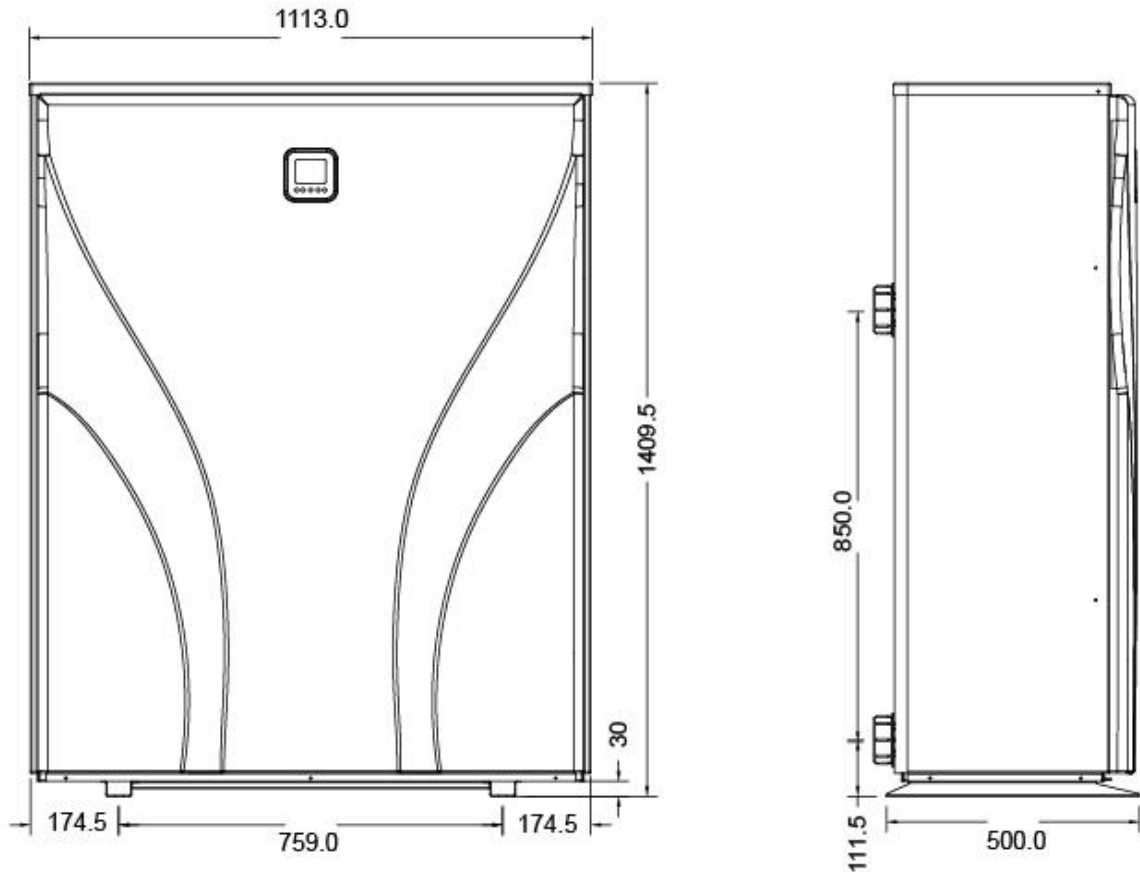

Unit: mm

### 3. Standort und Verbindung

#### 3.1 Installation

	<p><b>Antivibrationssockel</b></p> <ol style="list-style-type: none"><li>1. Nehmen Sie 4 Antivibrationssockel aus der Verpackung</li><li>2. Installieren Sie sie an der Unterseite der Maschine.</li></ol>
	<p><b>Ablassschraube</b></p> <ol style="list-style-type: none"><li>1. Installieren Sie die Ablassschraube unter der Bodenplatte</li><li>2. Verbinden Sie sie mit einer Wasserleitung, um das Wasser abzulassen.</li></ol> <p>Hinweis: Heben Sie die Wärmepumpe an, um die Ablassschraube zu installieren. Die Wärmepumpe niemals umkippen, da dies den Kompressor beschädigen könnte.</p>
	<p><b>Wasserzulauf- und Wasserablauf Anschluss</b></p> <ol style="list-style-type: none"><li>1. Installieren Sie die beiden Gelenke wie in der Abbildung gezeigt</li><li>2. Schrauben Sie sie auf den Wasserzulauf- und-ablaufanschluss</li></ol>
	<p><b>Netzkabelverdrahtung</b></p> <ol style="list-style-type: none"><li>1. Öffnen Sie die obere Abdeckung der Wärmepumpe.</li><li>2. Schließen Sie die Kabel gemäß Schaltplan an der richtigen Klemme an.</li></ol>

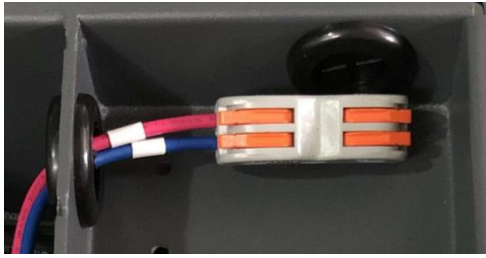

### Verkabelung der Filtrationspumpe (Trockenkontakt)

1. Öffnen Sie die obere Abdeckung der Wärmepumpe.
2. Schließen Sie die Kabel gemäß Schaltplan an der richtigen Klemme an.

### Anschluss zur Steuerung der Wasserpumpe

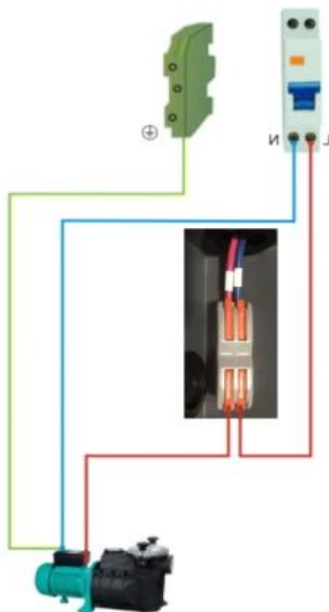
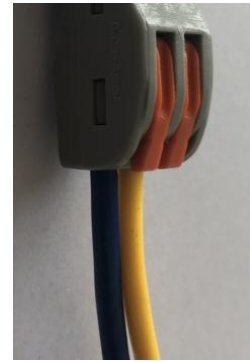
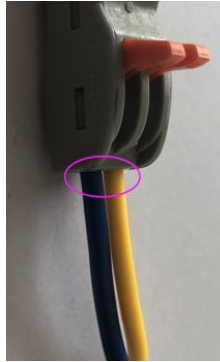
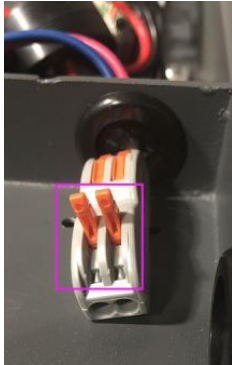

### **Achtung:**

Bitte halten Sie beim Installieren der Wärmepumpe folgende Regeln ein:

1. Jeder Zusatz von Chemikalien muss in der Rohrleitung stromabwärts der Wärmepumpe stattfinden.
2. Installieren Sie eine Bypass, wenn der Wasserfluss aus der Schwimmbadpumpe mehr als 20% größer ist als der maximal zulässige Durchfluss durch den Wärmetauscher der Wärmepumpe ist. Installieren Sie die Wasserpumpe über dem Wasserspiegel.
3. Stellen Sie die Wärmepumpe immer auf ein solides Fundament und bringen Sie die mitgelieferten Gummilager an um Vibrationen und Lärm zu vermeiden.
4. Die Wärmepumpe sollte immer lotrecht gehalten werden. Wenn das Gerät in einem Winkel gehalten wurde, warten Sie mindestens 24 Stunden bevor Sie sie verwenden.

### **3.2 Positionierung der Wärmepumpe**

Die Einheit wird an jeder gewünschten Position richtig arbeiten, solange die folgenden drei Elemente vorhanden sind:

- 1. Frische Luft** – **2. Elektrizität** – **3. Schwimmbecken-filter**

Die Einheit kann praktisch an jedem Standort im Außenbereich installiert werden, solange die angegebenen Mindestabstände zu anderen Objekten eingehalten werden (siehe Zeichnung unten). Bitte konsultieren Sie für die Installation an einem Indoor-pool einen Installateur. Die Installation an einem windigen Ort bereitet, anders als bei einem Gas-Heizer keinerlei Probleme.

**ACHTUNG:** Installieren Sie die Einheit niemals in einem geschlossenen Raum mit begrenztem Luftvolumen, wo die von der Einheit ausgestoßene Luft wiederverwendet wird, oder nahe an Sträuchern, die den Lufteinzug blockieren könnten. Solche Positionen beeinträchtigen die kontinuierliche Zufuhr von Frischluft, was die Effizienz reduziert, und möglicherweise auch die Wärmeabgabe behindert.

Für die minimalen Maße siehe Zeichnung unten:

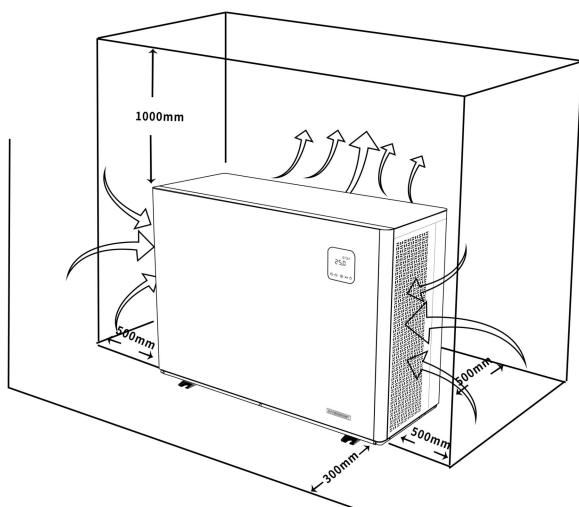



### 3.3 Entfernung von Ihrem Schwimmbad

Die Wärmepumpe wird normalerweise in einem Umkreis von 7,5 m vom Schwimmbad installiert. Je größer der Abstand zum Pool ist, desto größer ist der Wärmeverlust in den Rohren. Da die Rohre größtenteils unterirdisch sind, ist der Wärmeverlust für Entfernungen von bis zu 30 m (15 m von und zur Pumpe; insgesamt 30 m) gering, es sei denn, der Boden ist nass oder der Grundwasserspiegel ist hoch. Eine grobe Schätzung des Wärmeverlusts pro 30 m beträgt 0,6 kWh (2.000 BTU) pro 5 °C Differenz zwischen der Wassertemperatur im Pool und der Temperatur des das Rohr umgebenden Bodens. Dies erhöht die Betriebszeit um 3% bis 5%.

### 3.4 Installation des Sperrventils

Hinweis: Wenn ein automatisches Dosiergerät für den Chlor und Säuregehalt (pH) verwendet wird, ist es wichtig, die Wärmepumpe vor zu hohen chemischen Konzentrationen, die den Wärmetauscher korrodieren könnten, zu schützen. Aus diesem Grund müssen Geräte dieser Art stets in der Rohrleitung auf der stromabwärtigen Seite der Wärmepumpe montiert werden, und es wird empfohlen, ein Rückschlagventil zu installieren, um eine Rückströmung in der Abwesenheit von Wasserzirkulation zu verhindern.

Schäden an der Wärmepumpe, die durch Nichtbeachten dieser Vorschrift entstehen, werden nicht durch die Garantie gedeckt.

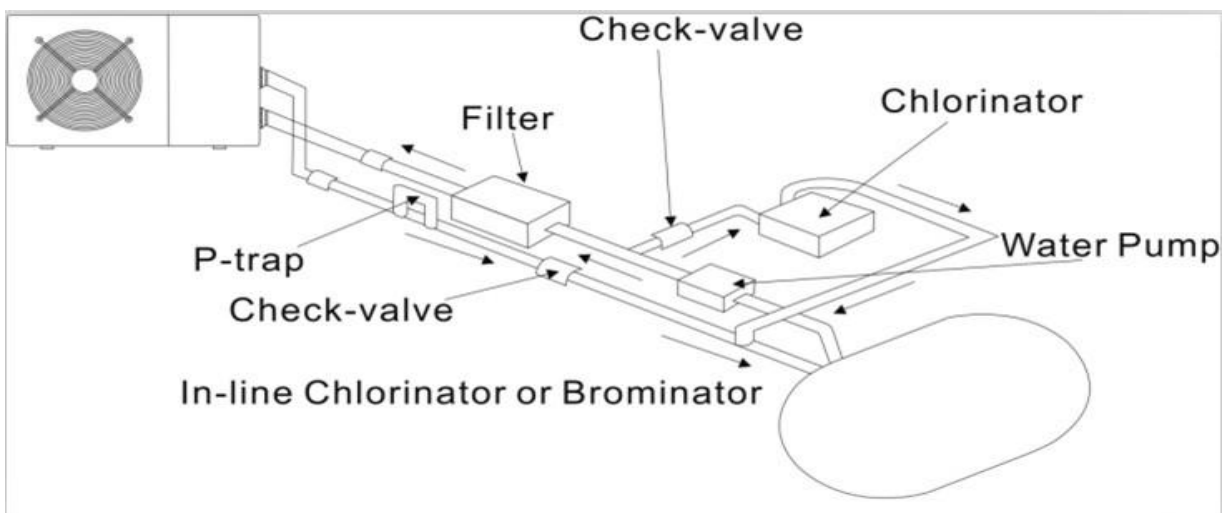

### 3.5 Typische Anordnung

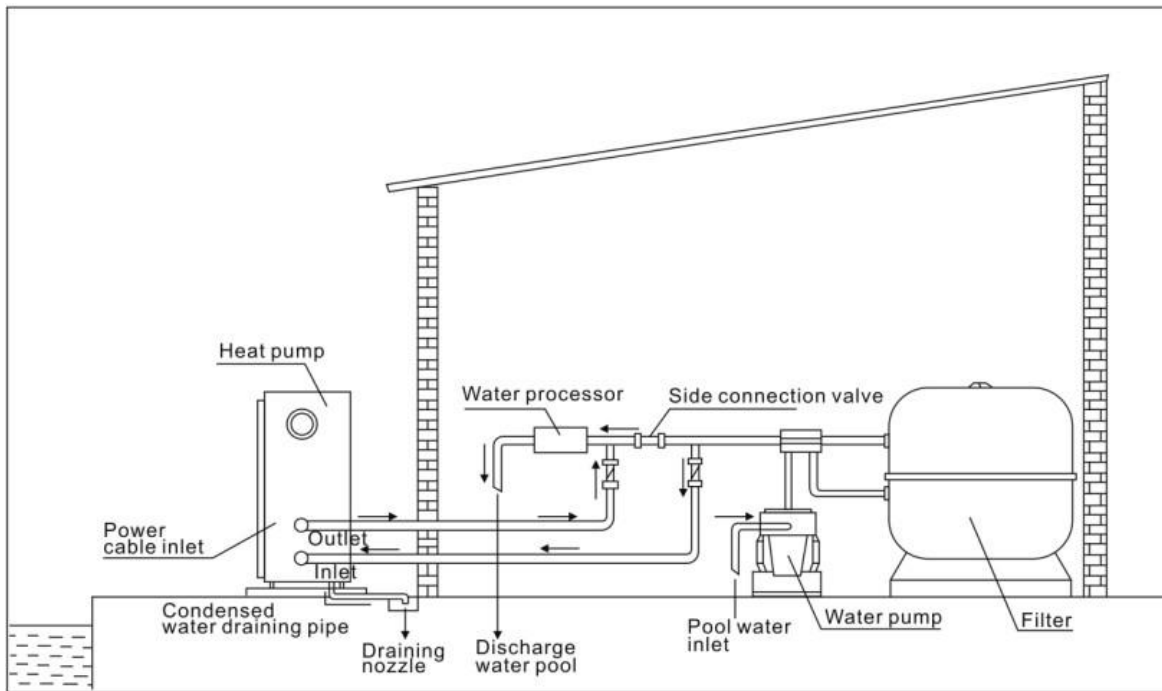

#### **NOTIZ**

Die Fabrik liefert nur die Wärmepumpe. Alle anderen Komponenten, einschließlich eines Bypass falls notwendig, muss vom Benutzer oder Installateur bereitgestellt werden.

#### **ACHTUNG:**

**Um das Wasser im Pool (oder Whirlpool) zu erwärmen, muss die Filterpumpe läuft werden, um den Wasser durch die Wärmepumpe zu zirkulieren. Die Wärmepumpe wird nicht gestartet werden, wenn das Wasser nicht zirkuliert.**

### 3.6 Erstinbetriebnahme

Nachdem alle Verbindungen hergestellt und geprüft sind, führen Sie die folgenden Schritte durch:

1. Schalten Sie die Filterpumpe aus. Prüfen Sie ob es ein Leck gibt, und stellen Sie sicher dass das Wasser vom und zum Schwimmbecken fließt.
2. Schließen Sie die Wärmepumpe an ein Stromnetz an und betätigen Sie die On/Off Taste  auf dem Bedienfeld. Das Gerät startet dann nach einer bestimmten Verzögerungszeit.
3. Überprüfen Sie nach ein paar Minuten ob die herausströmende Luft schon kühler ist.
4. Bei Ausschalten der Pumpe, sollte das Gerät auch automatisch ausschalten, wenn nicht, dann schalten Sie den Strömungswächter an.

5. Lassen Sie die Wärmepumpe und die Filterpumpe 24 Stunden am Tag laufen, bis die gewünschte Wassertemperatur erreicht ist. Die Wärmepumpe wird dann automatisch ausgeschaltet. Wenn die Wassertemperatur 2 Grad unter die gewünschte Temperatur sinkt, wird sie automatisch wieder eingeschaltet. Je nach Ausgangstemperatur des Wassers im Schwimmbad und der Lufttemperatur, kann es mehrere Tage dauern das Wasser auf die gewünschte Temperatur zu erwärmen. Eine gute Schwimmbadabdeckung könnte die erforderliche Zeit drastisch reduzieren.

 NOTIZ

Strömungswächter:

**Er soll sicherstellen dass das HP Gerät mit einer ausreichenden Durchflussrate läuft. Er wird eingeschaltet, wenn die Pool-Pumpe läuft und schaltet sich automatisch wieder aus, wenn die Pumpe abgeschaltet wird. Wenn das Wasser im Pool höher als 1 m über oder unter der Wärmepumpe steht, sollte ihr Händler alles nocheinmal neu einstellen.**

**Zeitverzögerung - Die Wärmepumpe hat eine eingebaute 3-Minuten-Anlaufverzögerung, um die Schaltung zu schützen und übermäßigen Verschleiß der Kontakte zu vermeiden. Das Gerät startet automatisch neu, nachdem diese Zeitspanne abgelaufen ist. Selbst ein kurzer Stromausfall löst diese Zeitverzögerung aus, und verhindern so, dass das Gerät nach einem Neustart sofort wieder läuft. Zusätzliche Stromunterbrechungen während dieser Verzögerung haben keinen Einfluss auf die 3-Minuten Dauer der Verzögerung.**

### **3.7 Kondensation**

Die Luft die in die Wärmepumpe gezogen wird ist stark durch den Betrieb der Wärmepumpe zur Erwärmung des Beckenwassers abgekühlt, was zu Kondensation an den Rippen des Verdampfers führen könnte.

 NOTIZ

Die Menge an Kondensationsprodukt kann bei relativ hoher Luftfeuchtigkeit mehrere Liter pro Stunde betragen. Daraus wird oft fälschlicherweise auf das Vorhandensein von Wasserlecks geschlossen.

## 4. Den Bypass einstellen

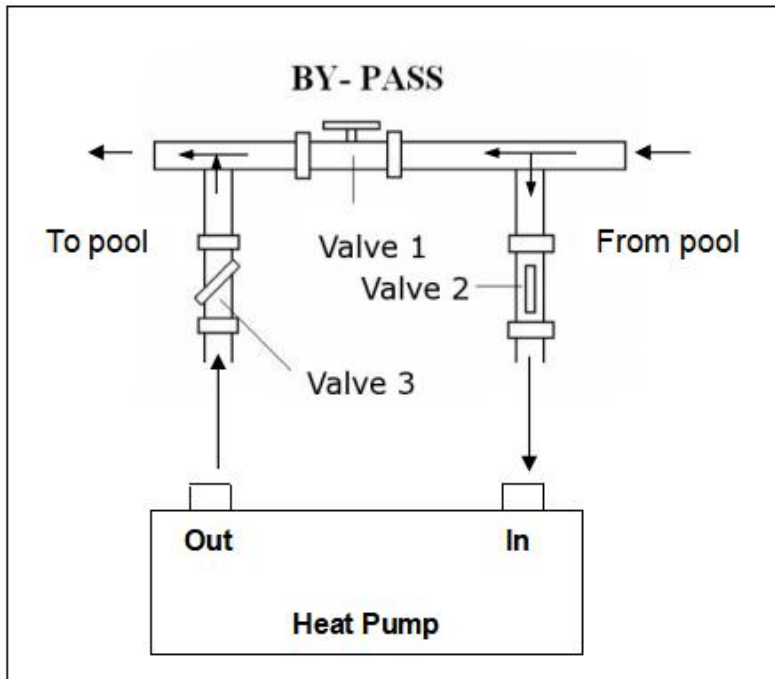

Gehen Sie wie folgt vor, um den Bypass einzustellen:

1. Ventil 1 weit geöffnet. Ventil 2 und Ventil 3 geschlossen.
2. Öffnen Sie langsam Ventil 2 und Ventil 3 zur Hälfte und schließen Sie anschließend langsam Ventil 1, um den Wasserdurchfluss zu Ventil 2 und Ventil 3 zu erhöhen.
3. Wenn auf dem Display „ON“ oder „EE3“ angezeigt wird, bedeutet dies, dass der Wasserdurchfluss in die Wärmepumpe nicht ausreicht. Sie müssen die Ventile einstellen, um den Wasserdurchfluss durch die Wärmepumpe zu erhöhen.

So erreichen Sie den optimalen Wasserfluss:

Bitte schalten Sie die Wärmepumpe unter Heizfunktion ein, schließen Sie zuerst den Bypass und öffnen Sie ihn anschließend langsam, um die Wärmepumpe zu starten (die Maschine kann nicht starten, wenn der Wasserdurchfluss nicht ausreicht).

Passen Sie den Bypass weiter an, und prüfen Sie gleichzeitig die Wasserein- und Wasseraustrittstemperatur. Die Einstellung ist optimal, wenn die Temperaturdifferenz ca. 2 Grad beträgt.

**Strömungswächter:**

Die Pumpe ist mit einem Strömungswächter ausgestattet, der die Pumpe vor einer unzureichenden Wasserdurchflussrate schützt. Er schaltet sich ein, wenn die Poolpumpe läuft, und schaltet sich aus, wenn die Pumpe abgeschaltet wird. Wenn der Poolwasserstand mehr als 1 m über oder unter dem automatischen Einstellknopf der Wärmepumpe liegt, muss Ihr Händler möglicherweise den Anfangswert anpassen.

**Zeitverzögerung** - Die Wärmepumpe verfügt über eine integrierte Anlaufverzögerung von 3 Minuten, um die Schaltung zu schützen und übermäßigen Kontaktverschleiß zu vermeiden. Das Gerät startet nach Ablauf dieser Zeitverzögerung automatisch neu. Selbst eine kurze Unterbrechung der Stromversorgung löst diese Zeitverzögerung aus und verhindert, dass das Gerät sofort neu startet. Zusätzliche Stromunterbrechungen während dieser Verzögerungszeit wirken sich nicht auf die Dauer der Verzögerung von 3 Minuten aus.

## 5. Bedienung des Steuergeräts

### 5.1. Betriebsanleitung





Wenn die Wärmepumpe an die Stromversorgung angeschlossen wird, zeigt die LED-Anzeige 3 Sekunden lang einen Code an, der das Wärmepumpenmodell anzeigt.

### 5.2 Die Tasten und ihre Bedienung

#### 5.2.1 -Taste

Betätigen Sie , um die Wärmepumpe zu starten, zeigt die LED-Anzeige die gewünschte Wassertemperatur für 5 Sekunden, dann die Einlasswassertemperatur und den Betriebsmodus an.



Drücken Sie , um die Wärmepumpe zu stoppen und "OFF"

Achtung: Drücken Sie während der Überprüfung und Einstellung des Parameters die Taste , um die aktuelle Einstellung zu beenden und die aktuelle Einstellung zu speichern.

Drücken Sie erneut , um das Gerät ein- oder auszuschalten.



#### 5.2.2 Taste und

Sperrten/entsperren die Anzeige:

Halten Sie  und  für 5 Sekunden, um die Anzeige zu sperren / zu entsperren.

Das Display wird nach 30 Sekunden Standby automatisch gesperrt. (Wenn das Display gesperrt ist, leuchtet das Symbol "Schließfach " auf)

## Wassertemperatur:

Drücken Sie  oder , um die Wassertemperatur direkt einzustellen.

Einstellbereich für Heizmodus und Auto-Modus: 6-41 °C

Einstellbereich für den Kühlmodus: 6-35 °C

### 5.2.3 Tastenarbeitsmodus

Drücken Sie  um den Arbeitsmodus, Turbo, Smart und Silent zu ändern. Der Standardmodus ist der Smart-Modus.

Während Sie den **Turbo** wählen, leuchtet das Wort "**Turbo**", die Wärmepumpe arbeitet nur mit "voller Leistung".

Wählen Sie den **Smart**, das Wort "**Smart**" leuchtet auf und die Wärmepumpe arbeitet mit „mittlerer und voller Leistung“.

Wählen Sie **Silent**, das Wort "**Lautlos**" leuchtet, die Wärmepumpe arbeitet mit "mittlerer und kleiner Leistung".

### 5.2.4 Tastenmodus

Drücken Sie  für 5S, um den Heizmodus , den Kühlmodus  und den Auto-Modus

umzuschalten .

Anmerkung: Beim Abtauen blinkt das Heizungssymbol.

### Betriebslogik des Auto-Modus

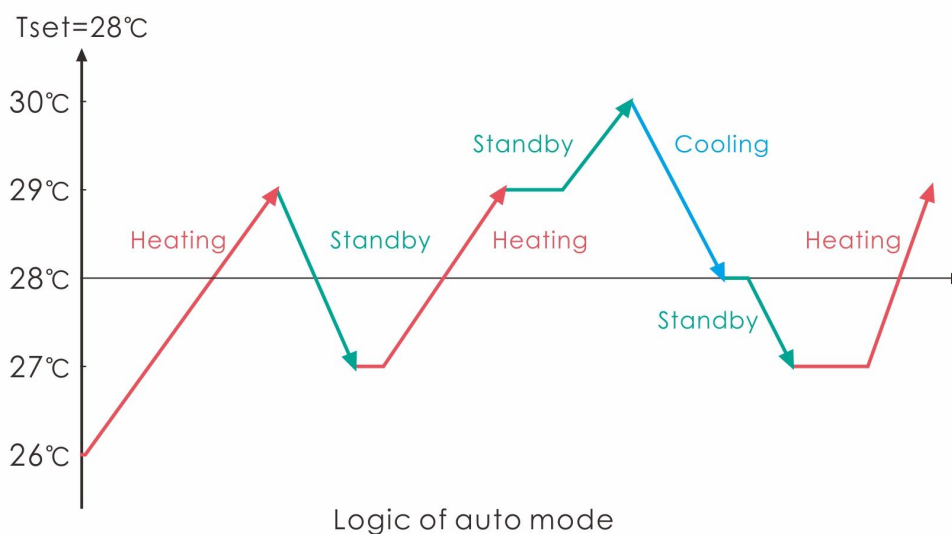

## 5.2.5 Parameterprüfung:

Drücken Sie zuerst  und drücken Sie dann , um den Benutzerparameter von d0 bis d14 zu



überprüfen

Code	Bedingung	Umfang	Anmerkung
d0	IPM Werkzeugtemperatur	0-120°C	Realer Prüfwert
d1	Einlaufwassertemp.	-9°C ~ 99°C	Realer Prüfwert
d2	Auslaufwassertemp.	-9°C ~ 99°C	Realer Prüfwert
d3	Umgebungstemp.	-30°C ~ 70°C	Realer Prüfwert
d4	Frequency Begrenzungscode	0,1,2,4,8,16	Realer Prüfwert
d5	Rohrleitungstemp.	-30°C ~ 70°C	Realer Prüfwert
d6	Abgastemperatur	0°C ~ C5°C (125°C)	Realer Prüfwert
d7	Schritt der EEV	0~99	N*5
d8	Betriebsfrequenz des Verdichters	0~99Hz	Realer Prüfwert
d9	Verdichterstrom	0~30A	Realer Prüfwert
d10	Aktuelle Lüfterdrehzahl	0-1200 (rpm)	Realer Prüfwert
d11	Fehlercode für das letzte Mal	Allen Fehlercode	

### Anmerkung:

**d4: Frequenzbegrenzungscode,**

**0: Keine Frequenzbegrenzung;**

**1: Temperaturbegrenzung des Spulenrohres;**

**2: Überhitzungs- oder Unterkühlungsfrequenzgrenze; 4: Frequenzgrenze des Antriebsstroms;**

**8: Frequenzbegrenzung der Antriebsspannung;**

**16: Frequenzbegrenzung der Hochtemperaturfrequenz des Antriebs**

## 5.2.6 Parametereinstellung

Drücken Sie zuerst , dann , um den Wert P0-P18 auszuwählen, und drücken Sie  erneut,

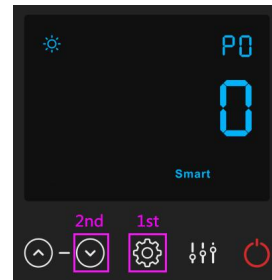

um die Einstellungsoberfläche aufzurufen, in der der Parameter blinkt.







Code	Name	Umfang	Standard	Anmerkung
P0	Mandatory Abtauen	0-1	0	0: Standard Normalbetrieb, 1: Mandatory Abtauen
P1	Arbeitsmodus	0-1	1	1 Heizbetrieb, 0 Kühlbetrieb
P2	Timer ein / aus	0-1	0	1 Timer ein / aus ist unter Funktion, 0 Timer ein / aus ist außer Funktion (Die Einstellung von P5 und P6 funktioniert nicht)
P3	Wasserpumpe	0-1	0	1 Immer laufend, 0 Abhängig vom Betrieb des Kompressors
P4	Aktuelle Uhrzeit	HH:MM	0:00	<u>0-23:0-59</u>
P5	Timer an	HH:MM	0:00	<u>0-23:0-59</u>
P6	Timer ausgeschaltet	HH:MM	0:00	<u>0-23:0-59</u>
P7	Einlaufwasserte mp. Korrektur	-9~9	0	Voreinstellung: 0
P14	Auf Werkseinstellungen zurücksetzen	0-1	0	1-Auf Werkseinstellungen zurücksetzen , 0- Standard (Wiederherstellen von P0, P1, P2, P3, P5, P6, P7, P8, P9, 10, P11 auf Werkseinstellung)
P16	Produktcode	/	/	Abhängig von der Maschine
P18	Mode	0-1	0	1—Heating only, 0—Heating/Cooling/Auto mode

Hinweis:

- 1). Drücken Sie  20 Sekunden lang, um P14, P16, P18 einzustellen.
- 2). Die Parameter P8, P9, P10, P11, P19, P20 gelten nur für die Werkseinstellung.



### 5.2.7 System-Reset-Funktion

Drücken Sie zuerst  und dann , um P14 auszuwählen, und drücken Sie  20 Sekunden lang, um die Einstellungsoberfläche aufzurufen, in der der Parameter blinkt. Drücken Sie  oder , um den richtigen Wert 1 einzustellen, und drücken Sie schließlich , um die Einstellungen zu speichern.

### 5.2.8

Als Symbol für TIMER ON leuchtet das Licht, wenn der Wert von P2 1 ist. Dies bedeutet, dass die Funktion TIME ON & OFF funktioniert. Stellen Sie dann die aktuelle Zeit (Parameter P4), TIMER EIN (Parameter P5) und TIMER AUS (Parameter P6) ein. Alle Symbole (außer Symbol ) auf dem Display sind ausgeschaltet, wenn der TIMER ausgeschaltet ist.

Hinweis: Das Symbol  leuchtet, wenn die Wärmepumpe nach TIME OFF neu gestartet wird, es sei denn, der Wert von P2 ist auf 0 gesetzt.

### 5.2.9 Pilotfunktion der Systemfiltration

**Option 1; P3 = 0 Die Filterpumpe bezieht sich auf den Betrieb der Wärmepumpe zum Starten und Stoppen.**

Die Wasserpumpe startet 60s vor dem Kompressor, die Wasserpumpe startet 30s und erfasst dann den Wasserflussschalter. Wenn die Wärmepumpe in den Standby-Modus wechselt, stoppt die Kompressors nach dem Stopp des Wasserpumpe 5 Minuten.

Die Wasserpumpe wird für 5 Minuten neu gestartet und dann gestoppt, wenn die Standby-Zeit mehr als 1 Stunden beträgt.

	Bedingung	Beispiel	Funktionslogik der Wasserpumpe
Heizmodus	P3=0, $T1 \geq T_{set} - 0.5^\circ\text{C}$ , 30 Minuten dauern	P3=0, $T1 \geq 27.5^\circ\text{C}$ , 30 Minuten dauern	Die Wasserpumpe wechselt für 1 Stunden in den Standby-Modus und startet nur außer, die Stromversorgung abzuschalten und neu zu starten. Die Wärmepumpe startet 5 Minuten nach dem Verlassen der Wasserpumpe aus dem Standby-Modus, um die Wassertemperatur T1 erneut zu ermitteln.
Kühlmodus	P3=0, $T1 \leq T_{set} + 0.5^\circ\text{C}$ , 30 Minuten dauern	P3=0, $T1 \leq 28.5^\circ\text{C}$ , 30 Minuten dauern	Die Wasserpumpe wechselt für 1 Stunden in den Standby-Modus und startet nur außer, die Stromversorgung abzuschalten und neu zu starten. Die Wärmepumpe startet 5 Minuten nach dem Verlassen der Wasserpumpe aus dem Standby-Modus, um die Wassertemperatur T1 erneut zu ermitteln.

**Option 2; P3 = 1 Filterpumpe ist immer eingeschaltet, P2 = 0 Die Timerfunktion ist nicht aktiv**

Unter der Bedingung P3 = 1, wenn  $T1 \geq T_{set} + 1^\circ\text{C}$  ( $T1 \geq 29^\circ\text{C}$ ) 3 Minuten dauern, befindet sich die Wärmepumpe im Standby-Modus, während die Filterpumpe immer eingeschaltet ist.

Wenn die Wärmepumpe manuell ausgeschaltet wird oder ZEIT AUS ist, stoppt die Filterpumpe entsprechend. Unter Option 2 mit Aktivierung des Timers; P2 = 1 zum Starten und Stoppen der Filtrationspumpe gemäß der Programmierung von P4 (Zeit), P5 (Timer EIN) und P6 (Timer AUS)

**Bedingung für den Start der Wärmepumpe, Timer EIN ist aktiv;**

Wenn der Timer die eingestellte Zeit von TIMER ON erreicht, startet die Filtrationspumpe und nach 5 Minuten startet die Wärmepumpe. Die Wärmepumpe bleibt angehalten, wenn die Wassertemperatur  $\geq T_{set} + 1^\circ\text{C}$  ( $T1 \geq 29^\circ\text{C}$ ) ist. Vor dem TIMER OFF ist die Filtration immer noch aktiviert.

**Bedingung zum Stoppen der Wärmepumpe, Timer AUS ist aktiv;**

Wenn der Timer die eingestellte Zeit von TIMER OFF erreicht, stoppt die Wärmepumpe und nach 5 Minuten stoppt die Filtrationspumpe.

**HINWEIS :**

$T_{set}$  = Tsetting Wassertemperatur

Zum Beispiel :  $T_{set} = 28^\circ\text{C}$  Tsetting wassertemperatur in Ihrer Pool-Wärmepumpe

$T_{set} - 0.5$  = less  $0.5^\circ\text{C}$  than Tsetting temperatur;  $T_{set} - 0.5 = 28 - 0.5 = 27.5^\circ\text{C}$

$T_{set} + 0.5$  = more  $0.5^\circ\text{C}$  than Tsetting temperatur;  $T_{set} + 0.5 = 28 + 0.5 = 28.5^\circ\text{C}$

### 5.3 Heizungslogik

Arbeits status		Arbeitsmodus	Wasser in der Temperatur-T1	Zum Beispiel, Wasser in der Temperatur-T1	Arbeitsniveau der Wärmepumpe
1	Inbetriebnahme der Wärmepumpe	Wenn Sie den "Smart-Arbeitsmodus" wählen	$T1 < T_{set}-1$	$T1 < 27^{\circ}\text{C}$	Powerful mode-Frequenz F9
2			$T_{set}-1 \cong T1 < T_{set}$	$27^{\circ}\text{C} \cong T1 < 28^{\circ}\text{C}$	Frequenz: F9 -F8-F7,...,-F2
3			$T_{set} \cong T1 < T_{set}+ 1$	$28^{\circ}\text{C} \cong T1 < 29^{\circ}\text{C}$	Silent mode-frequency F2
4			$T1 \cong T_{set}+1$	$T1 \cong 29^{\circ}\text{C}$	HP wird Standby sein, aufhören zu arbeiten, bis die Wassertemperatur auf weniger als $28^{\circ}\text{C}$ fällt.
5		Wenn Sie den "Stillen Arbeitsmodus" wählen.	$T1 < T_{set}$	$T1 < 28^{\circ}\text{C}$	Smart mode -Frequenz F5.
6			$T_{set} \cong T1 < T_{set}+1$	$28^{\circ}\text{C} \cong T1 < 29^{\circ}\text{C}$	Silent mode-Frequenz F2/F1.
7			$T1 \cong T_{set}+1$	$T1 \cong 29^{\circ}\text{C}$	HP wird Standby sein, aufhören zu arbeiten, bis die Wassertemperatur auf weniger als $28^{\circ}\text{C}$ fällt.
8		Wenn Sie den "Leistungsfähigen Arbeitsmodus" auswählen.	$T1 < T_{set}+1$	$T1 < 29^{\circ}\text{C}$	Powerful mode-Frequenz F10/F9
9			$T1 \cong T_{set}+1$	$T1 \cong 29^{\circ}\text{C}$	HP wird Standby sein, aufhören zu arbeiten, bis die Wassertemperatur auf weniger als $28^{\circ}\text{C}$ fällt.
10	Starten Sie erneut, um Wasser im Standby-Status zu erhitzen	Wenn HP im "Smart-Modus" arbeitet	$T1 \cong T_{set}$	$T1 \cong 28^{\circ}\text{C}$	Standby
11			$T_{set} > T1 \cong T_{set}-1$	$28^{\circ}\text{C} > T1 \cong 27^{\circ}\text{C}$	Silent-frequenz F2
12			$T_{set}-1 > T1 \cong T_{set}-2$	$27^{\circ}\text{C} > T1 \cong 26^{\circ}\text{C}$	Frequenz: F2 -F3-F4,...,-F9
13			$< T_{set}-2$	$< 26^{\circ}\text{C}$	Powerful-frequenz F9
14		Wenn HP im "Silent Mode" arbeitet	$\cong T_{set}$	$\cong 28^{\circ}\text{C}$	Standby
15			$T_{set} > T1 \cong T_{set}-1$	$28^{\circ}\text{C} > T1 \cong 27^{\circ}\text{C}$	Silent mode-frequenz F2/F1
16			$T1 < T_{set}-1$	$T1 < 27^{\circ}\text{C}$	Smart -frequenz F5
17	Wenn HP im "Leistungsstarken Modus" arbeitet	$T1 < T_{set}-1$	$T1 < 27^{\circ}\text{C}$	Powerful -frequenz F10/F9	

## 6. Fehlerbehebung

### 6.1 Fehlercodeanzeige auf einer LED-Kabelsteuerung

Fehlfunktion	Fehler code	Grund	Lösung
Hochdruckversagen	EE 01	<ol style="list-style-type: none"> <li>1.Hochdruckschalter in schlechtem Anschluss oder Ausfall</li> <li>2.Ambient Temperatur ist zu hoch</li> <li>3.Wassertemperatur ist zu hoch</li> <li>4.Wasserfluss ist zu niedrig</li> <li>5.Fan Motordrehzahl ist abnormal oder Ventilatormotor hat beschädigt</li> </ol>	<ol style="list-style-type: none"> <li>1. Überprüfen Sie die Verdrahtung auf einen Hochdruckschalter oder ändern Sie eine neue</li> <li>2. Überprüfen Sie den Wasserfluss oder die Wasserpumpe</li> <li>3. Ventilator prüfen</li> <li>4. Das Rohrleitungssystem prüfen und reparieren</li> </ol>
Niederdruckversagen	EE 02	<ol style="list-style-type: none"> <li>1. Niederdruckschalter bei schlechtem Anschluss oder Ausfall</li> <li>2.EEV ist blockiert oder Rohrsystem ist gestaut</li> <li>3.Motorgeschwindigkeit ist abnormal oder Motor hat beschädigt</li> <li>4.Gas Leckage</li> </ol>	<ol style="list-style-type: none"> <li>1. Die Verdrahtung auf Niederdruck prüfen oder eine neue ändern</li> <li>2.Verwenden Sie die EEV und das Rohrleitungssystem</li> <li>3. Motor prüfen</li> <li>3. Durch das Hochdruckmessgerät zur Überprüfung des Druckwertes</li> </ol>
Kein Wasserfluss oder Wasserflussschalteausfall	ON	<ol style="list-style-type: none"> <li>1.Wasser-Flow-Schalter ist in schlechter Verbindung</li> <li>2.Wasserstromschalter ist beschädigt</li> <li>3.No/ Unzureichender Wasserfluss.</li> </ol>	<ol style="list-style-type: none"> <li>1. Die Verdrahtung für den Wasserstromschalter prüfen</li> <li>2.Wählen Sie den Wasserflussschalter</li> <li>3.Check die Wasserpumpe oder die Wasserstraße System</li> </ol>
Überheizungsschutz für Wassertemperatur (T2) im Heizbetrieb	EE 04	<ol style="list-style-type: none"> <li>1.Low Wasserfluss</li> <li>2.Wasser-Flow-Schalter ist fest und die Wasserversorgung ist abgeschnitten</li> <li>3. T2-Sensor ist abnormal</li> </ol>	<ol style="list-style-type: none"> <li>1.Warten Sie das Wasser Weg System</li> <li>2. Wasserpumpe oder Wasserstromschalter prüfen</li> <li>3. T2-Sensor prüfen oder einen anderen ändern</li> </ol>
Abgastemperatur (T6) zu hoher Schutz	EE 05	<ol style="list-style-type: none"> <li>1.Lack von Gas</li> <li>2.Low Wasserfluss</li> <li>3.Piping-System wurde blockiert</li> <li>4.Auslasstemperatur Sensorfehler</li> </ol>	<ol style="list-style-type: none"> <li>1. Überprüfen Sie das Hochdruckmanometer, wenn es zu niedrig ist, füllen Sie es mit etwas Gas</li> <li>2. Überprüfen Sie das Wasserstraßensystem und die Wasserpumpe</li> <li>3.Überprüfen Sie das Rohrleitungssystem, wenn es einen Block gab</li> <li>4. Ändern Sie einen neuen Abgastempersensoren</li> </ol>
Reglerfehler oder Kommunikationsfehler	EE 06	<ol style="list-style-type: none"> <li>1. Drahtverbindung ist nicht gut oder beschädigter Signaldraht</li> <li>2. Controller fehler</li> </ol>	<ol style="list-style-type: none"> <li>1. Überprüfen und wieder anschließen der Signalleitung</li> <li>2.Schneiden Sie einen neuen Signaldraht</li> <li>3. Stromversorgung abschalten und Maschine neu starten</li> <li>4. Ändern eines neuen Controllers</li> </ol>

Verdichterstromschutz	EE 07	<ol style="list-style-type: none"> <li>1. Der Kompressorstrom ist zu groß momentan</li> <li>2. Wrong Anschluss für Kompressor-Phasenfolge</li> <li>3. Kompressor Ansammlungen von Flüssigkeit und Öl führen zum Strom wird größer</li> <li>4. Kompressor oder Fahrerboard beschädigt</li> <li>5. Die Wasserströmung ist abnormal</li> <li>6. Kraftschwankungen innerhalb kurzer Zeit</li> </ol>	<ol style="list-style-type: none"> <li>1. Kompressor prüfen</li> <li>2. Überprüfen Sie die Wasserstraße</li> <li>3. Überprüfen Sie, ob die Stromversorgung im normalen Bereich erfolgt</li> <li>4. Überprüfen Sie die Phasenfolgeverbindung</li> </ol>
Kommunikationsfehler zwischen der Steuerung und der Hauptplatine	EE 08	<ol style="list-style-type: none"> <li>1. Poor-Signalleitung oder beschädigte Signalleitung</li> <li>2. Controller-Störung</li> </ol>	<ol style="list-style-type: none"> <li>1. Überprüfen und wieder anschließen der Signalleitung</li> <li>2. Schneiden Sie einen neuen Signaldraht</li> <li>3. Stromversorgung abschalten und Maschine neu starten</li> <li>4. Ändern eines neuen Controllers</li> </ol>
Kommunikationsfehler zwischen Hauptplatine und Treiberplatine	EE 09	<ol style="list-style-type: none"> <li>1. Anschluss der Verbindung Draht</li> <li>2. Der Draht ist beschädigt</li> </ol>	<ol style="list-style-type: none"> <li>1. Drücken Sie den Drahtanschluss</li> <li>2. Keile einen neuen Draht</li> </ol>
VDC-Spannung zu hoher Schutz	EE 10	<ol style="list-style-type: none"> <li>1. Mother Netzspannung ist zu hoch</li> <li>2. Driver Bord ist beschädigt.</li> </ol>	<ol style="list-style-type: none"> <li>1. Überprüfen Sie, ob die Stromversorgung im normalen Bereich liegt</li> <li>2. Fahren Sie an Bord oder Hauptplatine</li> </ol>
Schutz der IPM-Module	EE 11	<ol style="list-style-type: none"> <li>1. Datenfehler</li> <li>2. Krong Verdichterphasenanschluss</li> <li>3. Kompressor Flüssigkeit und Öl Anhäufung führen zum Strom wird größer</li> <li>4. Kompressor oder Fahrerboard beschädigt</li> </ol>	<ol style="list-style-type: none"> <li>1. Programmfehler, Stromversorgung abschalten und nach 3 Minuten neu starten</li> <li>2. Fahren Sie mit dem Fahrerboard</li> <li>3. Kompressor-Sequenzverbindung prüfen</li> </ol>
VDC-Spannung zu wenig Schutz	EE 12	<ol style="list-style-type: none"> <li>1. Mother Netzspannung ist zu niedrig</li> <li>2. Driver Bord ist beschädigt.</li> </ol>	<ol style="list-style-type: none"> <li>1. Prüfen Sie, ob die Stromversorgung im normalen Bereich liegt</li> <li>2. Fahrertreiber wechseln</li> </ol>
Eingangsstrom über hohen Schutz.	EE 13	<ol style="list-style-type: none"> <li>1. Der Kompressorstrom ist zu groß momentan</li> <li>2. Die Wasserströmung ist abnormal</li> <li>3. Kraftschwankungen innerhalb kurzer Zeit</li> <li>4. Wrong PFC Induktivität</li> </ol>	<ol style="list-style-type: none"> <li>1. Kompressor prüfen</li> <li>2. Überprüfen Sie die Wasserstraße</li> <li>3. Überprüfen Sie, ob die Stromversorgung im normalen Bereich liegt</li> <li>4. Überprüfen Sie, ob die korrekte PFC-Induktivität verwendet wird</li> </ol>
Der thermische Schaltkreis des IPM-Moduls ist abnormal	EE 14	<ol style="list-style-type: none"> <li>1. Ausgang Abnormalität der IPM-Modul thermischen Kreislauf Motor</li> <li>2. Fan ist abnormal oder beschädigt</li> <li>3. Fan Klinge ist gebrochen</li> </ol>	<ol style="list-style-type: none"> <li>1. Fahren Sie eine Fahrerkarte</li> <li>2. Überprüfen Sie, ob die Motordrehzahl zu niedrig ist oder der Lüftermotor beschädigt ist, ändern Sie einen anderen</li> <li>3. Ändern Sie eine andere Lüfterklinge</li> </ol>
Die Temperatur des IPM-Moduls ist zu hoch	EE 15	<ol style="list-style-type: none"> <li>Ausfahrt Ausnahme des IPM-Modul-Thermo-Schaltkreises</li> <li>2. Motor ist abnormal oder beschädigt</li> <li>3. Fan Klinge ist gebrochen</li> </ol>	<ol style="list-style-type: none"> <li>1. Fahren Sie eine Fahrerkarte</li> <li>2. Überprüfen Sie, ob die Lüftermotordrehzahl zu niedrig ist oder der Lüftermotor beschädigt ist, ändern Sie einen anderen</li> <li>3. Ändern Sie eine andere Lüfterklinge</li> </ol>

PFC-Modulschutz	EE 16	1.Ausgang Ausnahme des PFC-Moduls 2.Motor ist abnormal oder beschädigt 3.Fan Klinge ist gebrochen 4.Input Spannungssprung, Eingangsleistung ist abnormal	1. Fahren Sie eine Fahrerkarte 2. Überprüfen Sie, ob die Motordrehzahl zu niedrig ist oder der Lüftermotor beschädigt ist, ändern Sie einen anderen 3.Klappen Sie ein anderes Lüfterblatt 4. Überprüfen Sie die Eingangsspannung
DC-Lüftermotorausfall	EE 17	1.DC Motor ist beschädigt 2.Main Board ist beschädigt 3.Die Lüfterklinge ist fest	1.Detect DC-Motor, ersetzen durch eine neue 2.Verbinden Sie eine neue Hauptplatine 3.Finden Sie die Barriere aus und arbeiten Sie es aus
Der thermische Schaltkreis des PFC-Moduls ist abnormal	EE 18	Das Fahrer Brett ist beschädigt	1.Erfahren Sie eine neue Treiber-Board 2. Überprüfen Sie, ob die Lüftermotordrehzahl zu niedrig ist oder der Lüftermotor beschädigt ist, ändern Sie einen anderen
PFC-Modul Hochtemperaturschutz	EE 19	1.PFC Modul thermische Schaltung Ausgang anormal 2.Motor ist abnormal oder beschädigt 3.Fan Klinge ist gebrochen 4.Die Schraube im Fahrer Brett ist nicht fest	1.Erfahren Sie eine neue Treiber-Board 2. Überprüfen Sie, ob die Motordrehzahl zu niedrig ist oder der Lüftermotor beschädigt ist, ändern Sie einen anderen 3.Klappen Sie ein anderes Lüfterblatt 4. Überprüfen Sie, ob die Schraube locker ist
Der Eingangsstromausfall	EE 20	Die Versorgungsspannung schwankt zu stark	Überprüfen Sie, ob die Spannung stabil ist
Software-Steuerabweichung	EE 21	1.Kompressor läuft aus dem Schritt 2.Wrong Programm 3.Impurity im Kompressor verursacht die instabile Drehzahl	1. Überprüfen Sie die Hauptplatine oder ändern Sie eine neue 2.Geben Sie das richtige Programm ein
Stromdetektorausfall	EE 22	1.Spannungssignal abnormal 2.Driver Board ist beschädigt	1. Überprüfen Sie die Hauptplatine oder ändern Sie eine neue 2.Change eine neue Treiber-Board
Kompressorstart fehlgeschlagen	EE 23	1.Main Board ist beschädigt 2.Kompressor Verdrahtungsfehler oder schlechter Kontakt oder unverbunden 3. Flüssigkeitsansammlung innen 4.Wrong Phasenanschluss für Kompressor	1. Überprüfen Sie die Hauptplatine oder ändern Sie eine neue 2.Die Verdichterverdrahtung gemäß Schaltplan prüfen Prüfen Sie den Kompressor oder ändern Sie einen neuen
Umgebungs-Temperatur-Geräte-Fehler auf Treiber-Board	EE 24	Störung der Umgebungstemperatur	Fahrertreiber oder Hauptplatine wechseln
Kompressorphasenversagen	EE 25	Die Kompressoren U, V, W sind mit einer Phase oder zwei Phasen verbunden	Überprüfen Sie die tatsächliche Verdrahtung gemäß Schaltplan

4-Wege-Ventilumkehrversagen	EE 26	1.Four-Wege-Ventilumkehrversagen 2.Lack Kältemittel (keine Erkennung, wenn T3 oder T5 Störung)	1.Schalten Sie den Kühlmodus, um das 4-Wege-Ventil zu überprüfen, wenn es richtig umgekehrt wurde 2.Geben Sie ein neues 4-Wege-Ventil ein 3.Füllen Sie mit Gas
lesen Fehlfunktion von EEPROM-Daten	EE27	1.Wrong EEPROM Daten im Programm oder fehlgeschlagene Eingabe von EEPROM Daten 2.Main Board Ausfall	1. Geben Sie korrekte EEPROM-Daten ein 2.Change eine neue Hauptplatine
Der Inter-Chip-Kommunikationsfehler auf der Hauptsteuerplatine	EE28	Hauptbrettausfall	1. Die Stromversorgung abschalten und neu starten 2.Change eine neue Hauptplatine
Fehler beim Sensor für den Heizkondensator	PP 01	1.Sensorfehler oder Kurzschluss 2.Die Verdrahtung des Sensors ist lose	1. Die Verdrahtung der Sensoren reparieren 2.Schalten Sie den Sensor
Fehler beim Sensor für den Gasrücklauf	PP 02	1.Sensorfehler oder Kurzschluss 2.Die Verdrahtung des Sensors ist lose	1. Die Verdrahtung der Sensoren reparieren 2.Schalten Sie den Sensor
Fehler beim Sensor für die Umgebungstemperatur	PP 03	1.Sensorfehler oder Kurzschluss 2.Die Verdrahtung des Sensors ist lose	1. Die Verdrahtung der Sensoren reparieren 2.Schalten Sie den Sensor
Gasrücklaufsensorausfall	PP 04	1.Sensorfehler oder Kurzschluss 2.Die Verdrahtung des Sensors ist lose	1. Die Verdrahtung der Sensoren reparieren 2.Schalten Sie den Sensor
Frostschutz im Winter	PP 05	1.Sensorfehler oder Kurzschluss 2.Die Verdrahtung des Sensors ist lose	1. Die Verdrahtung der Sensoren reparieren 2.Schalten Sie den Sensor
Ausfall des Auspuffrohrsensors	PP 06	1.Sensorfehler oder Kurzschluss 2.Die Verdrahtung des Sensors ist lose	1. Die Verdrahtung der Sensoren reparieren 2.Schalten Sie den Sensor
Frostschutz im Winter	PP 07	Die Umgebungstemperatur oder die Wassereintrittstemperatur ist zu niedrig	Normaler Schutz
Niedriger Umgebungstemperaturschutz	PP 08	1.Geben Sie den Umfang der Nutzung der Umgebung 2.Sensor Anomalie	1.Stop verwenden, über den Umfang der Verwendung 2.Schalten Sie den Sensor
Rohrtemperatur zu hoch im Kühlbetrieb	PP 10	1. Ambient Temperatur ist zu hoch oder die Wassertemperatur ist zu hoch im Kühlmodus 2. Kälteanlage ist abnormal	1. Überprüfen Sie den Umfang der Verwendung 2.Kälteanlage prüfen

Wassertemperatur (T2) zu niedriger Schutz im Kühlmodus	PP 11	1. Low Wasserfluss 2. T2 Temperatursensor abnormal	1. Wasserpumpe und Wasserstraßensystem prüfen 2. Tauschen T2 Temperatursensor
--	-------	---	---

**Hinweis:**

1. Wenn im Heizmodus die Wasseraustrittstemperatur höher als die eingestellte Temperatur über 7 ° C ist, zeigt der LED-Controller EE04 für den Wasserüberhitzungsschutz an.
2. Wenn im Kühlmodus die Wasseraustrittstemperatur niedriger als die eingestellte Temperatur über 7 ° C ist, zeigt der LED-Controller PP11 für den Wasserüberkühlungsschutz an.

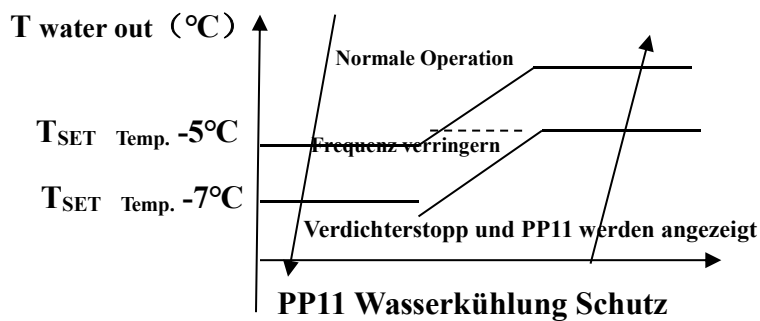
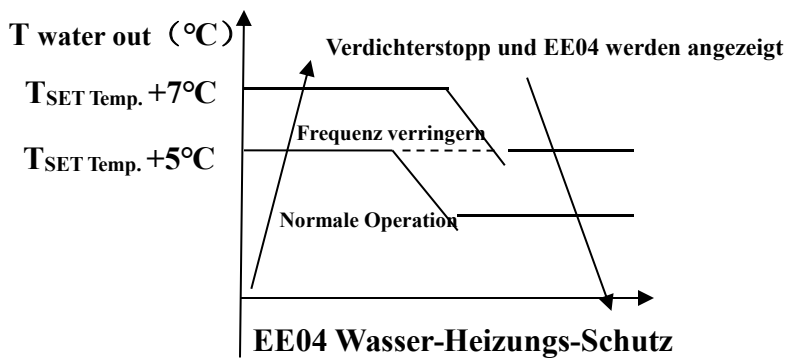

Zum Beispiel unten:

Modus	Wasseraustrittstemperatur	Temperatur einstellen	Bedingung	Fehlfunktion
Heizmodus	36°C	29°C	$T_{out} - T_{set} \cong 7^{\circ}C$	EE04 Überhitzungsschutz für Wassertemperatur (T2)
Kühlmodus	23°C	30°C	$T_{set} - T_{out} \cong 7^{\circ}C$	PP11 Zu niedriger Schutz für die Wassertemperatur (T2)



## 6.2 Andere Fehlfunktionen und ihre Lösung (werden nicht auf der LED-Kabelsteuerung angezeigt)

Fehlfunktion	Anzeichen	Ursachen	Lösung
Wärmepumpe läuft nicht	LED-Kabelsteuerung hat keine Anzeige	Keine Stromzufuhr	Überprüfen Sie ob Kabel und Schutzschalter verbunden sind
	LED-Kabelsteuerung zeigt die aktuelle Zeit an.	Wärmepumpe im Bereitschaftsmodus	Starten Sie die Wärmepumpe.
	LED-Kabelsteuerung zeigt die aktuelle Wassertemperatur an.	<ol style="list-style-type: none"> <li>1. Wassertemperatur erreicht den vorgesehenen Wert, HP ist auf konstantem Temperaturniveau</li> <li>2. Wärmepumpe hat erst zu arbeiten angefangen</li> <li>3. Im Auftaumodus</li> </ol>	<ol style="list-style-type: none"> <li>1. Überprüfen Sie die Wassertemperatureinstellungen.</li> <li>2. Starten Sie die Wärmepumpe nach ein paar Minuten.</li> <li>3. LED-Kabelsteuerung sollte "Defrosting" anzeigen.</li> </ol>
Die Wassertemperatur sinkt wenn HP im Heizmodus läuft	LED-Kabelsteuerung zeigt die aktuelle Wassertemperatur an und kein Fehlercode wird angezeigt	<ol style="list-style-type: none"> <li>1. Der falsche Modus wurde ausgewählt.</li> <li>2. Die Eingangsdaten sind falsch</li> <li>3. Steuerung ist defekt</li> </ol>	<ol style="list-style-type: none"> <li>1. Stellen Sie den Modus richtig ein</li> <li>2. Ersetzen Sie die defekte LED-Kabelsteuerung, und überprüfen Sie den Status nachdem Sie in den Betriebsmodus übergegangen sind, schließlich überprüfen Sie die Wassereintritts- und Austrittstemperatur.</li> <li>3. Ersetzen oder Reparieren Sie die Heipumpeneinheit</li> </ol>
Kurze Laufzeiten	LED-Bildschirm zeigt aktuelle Wassertemperatur an, kein Fehlercode wird angezeigt.	<ol style="list-style-type: none"> <li>1. Ventilator läuft nicht</li> <li>2. Luftzirkulation ist nicht ausreichend.</li> <li>3. Unzureichende Kühlmittel.</li> </ol>	<ol style="list-style-type: none"> <li>1. Überprüfen Sie die Kabelverbindungen zwischen dem Motor und dem Ventilator. Wenn nötig sollten Sie ersetzt werden.</li> <li>2. Überprüfen Sie die Position der Wärmepumpeneinheit, und entfernen Sie alle Hindernisse um eine optimale Luftzirkulation zu erreichen.</li> <li>3 Ersetzen oder reparieren Sie die Wärmepumpeneinheit.</li> </ol>
Wasserflecken	Wasserflecken auf der Wärmepumpeneinheit	<ol style="list-style-type: none"> <li>1. Beton.</li> <li>2. Wasserlecke.</li> </ol>	<ol style="list-style-type: none"> <li>1. Nichts tun.</li> <li>2. Überprüfen Sie den Luft-Wärmewechsle auf Defekte.</li> </ol>
Zu viel Eis am Verdampfer	Zu viel Eis am Verdampfer		<ol style="list-style-type: none"> <li>1. Überprüfen Sie die Position der Wärmepumpeneinheit, und entfernen Sie alle Hindernisse, um eine optimale Luftzirkulation zu erreichen.</li> <li>2. Ersetzen oder reparieren Sie die Wärmepumpeneinheit.</li> </ol>

# 7. Elektronische Verkabelung

## 7.1 Umrichter Schwimmbad Wärmepumpe Schaltplan

UX11Csi32/UX14Csi32/UX17Csi32/UX21Csi32

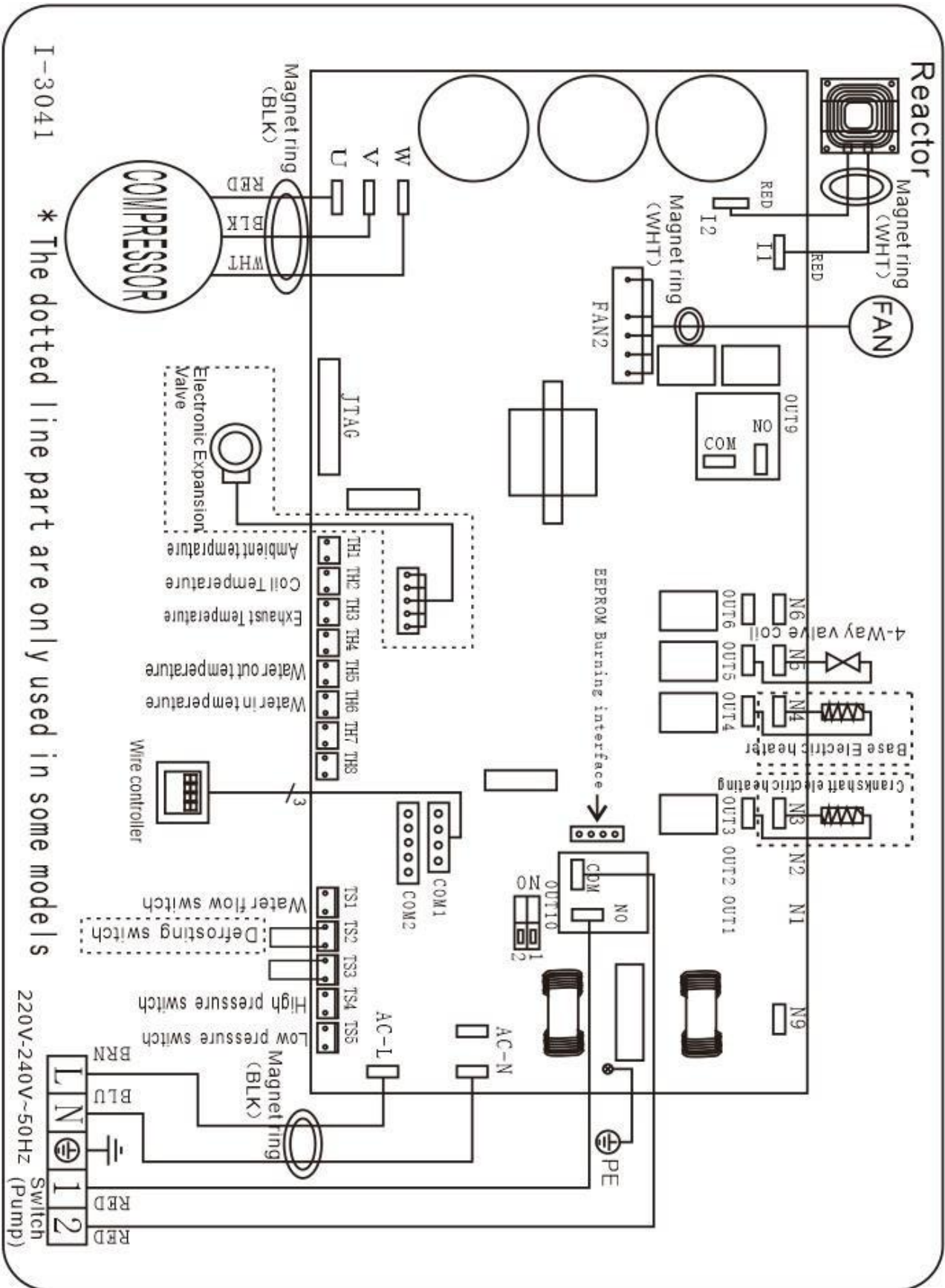

I-3051S \* The dotted line part are only used in some models

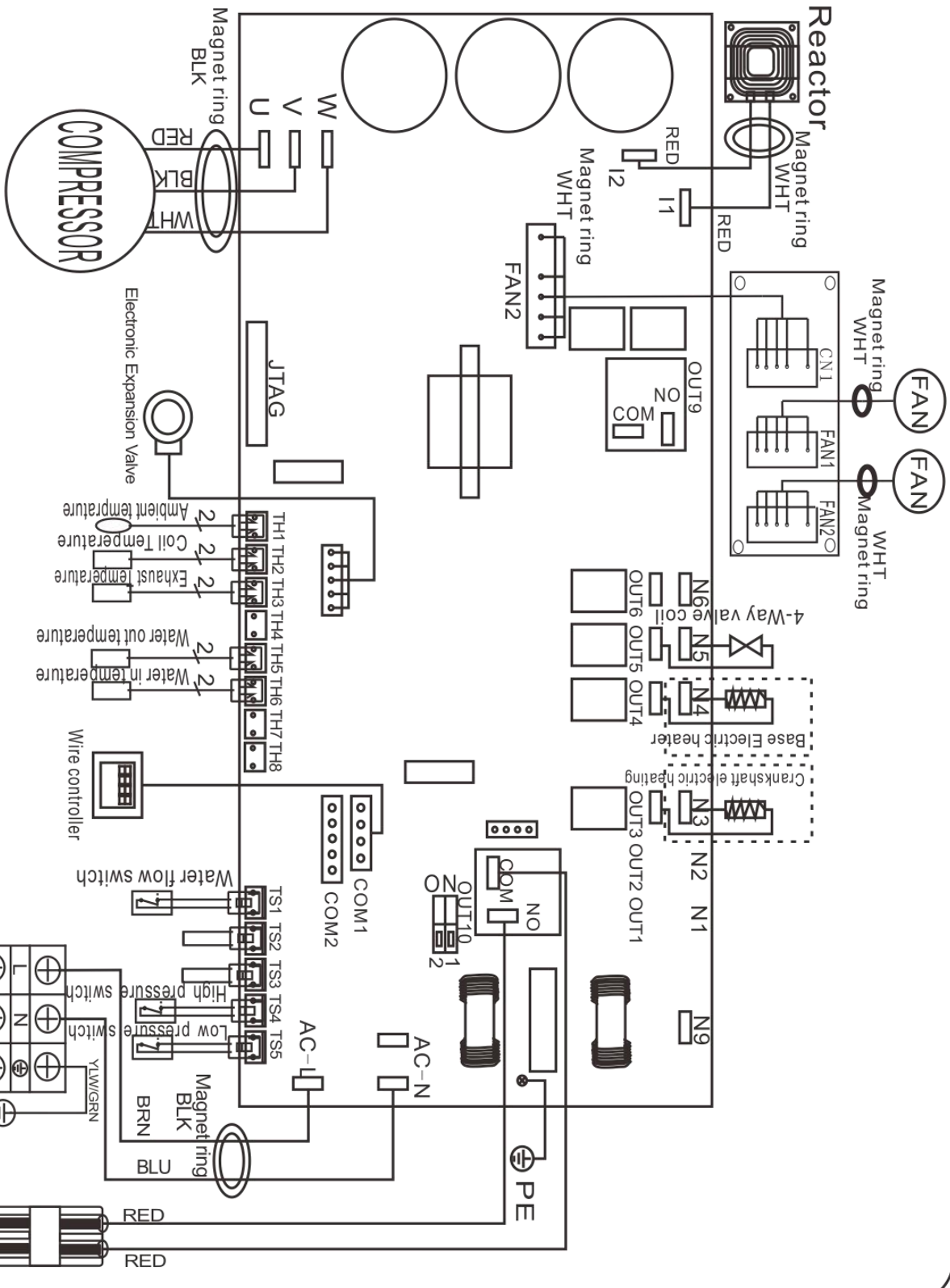

220V-240V~50HZ

SWITCHE (Water Pump)

I-5101

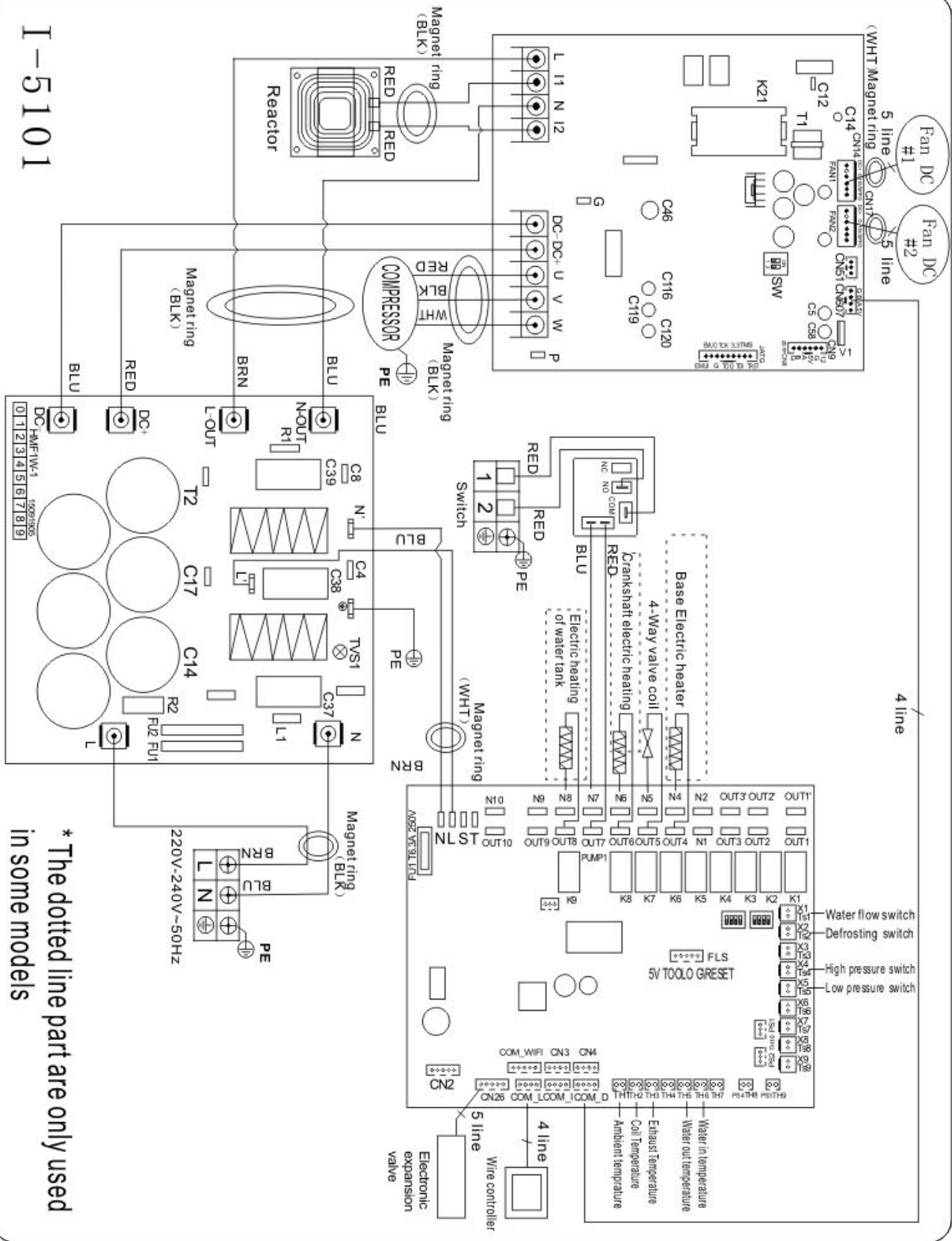



## 7.2 Elektronischer Schutz

### NOTIZ

Die Schwimmbecken-Wärmepumpe muss gut geerdet sein, auch wenn der Wärmewechsler vom Rest der Einheit elektrisch isoliert ist. Die Erdung ist dennoch wichtig, um Sie vor Kurzschlüssen im Inneren des Gerätes zu schützen. Verkleben ist ebenfalls erforderlich.

**ATTENTIE:** Ein Unterbrecher (d.h. ein circuit breaker, fused or un-fused switch) sollte in Sichtweite und vom Gerät aus leicht erreichbar positioniert werden..Das ist bei kommerziellen und häuslichen Wärmepumpen so üblich. Es schützt davor unbeaufsichtigte Einheiten mit Strom zu versorgen, und erlaubt die Einheit auszuschalten während sie verwendet wird.

## 8. Wartung

- 1) Sie sollten das Wasserzufuhrsystem regelmäßig überprüfen, um zu vermeiden dass Luft in das System eindringt und geringe Wasserflussmenge verursacht, denn das würde die Leistung und Zuverlässigkeit der HP-Einheit reduzieren.
- 2) Reinigen Sie ihr Becken und Filtersystem regelmäßig um Schäden an der Einheit durch verschmutzte Filter zu vermeiden.
- 3) Sie sollten das Wasser am Boden der Wasserpumpe auslassen, wenn die HP-Einheit für längere Zeit unbenutzt bleiben soll (besonders im Winter).
- 4) Ansonsten sollten überprüfen ob die Einheit mit Wasser gefüllt ist, bevor Sie sie starten.
- 5) Nachdem die Einheit für die Winterseason ausgerüstet wurde, sollte sie mit einer speziellen Winterdecke abgedeckt werden.
- 6) Während die Einheit läuft ist es normal wenn ein wenig Wasser darunter ausläuft.

# 9. Explosionszeichnung

Explosionszeichnung

UX11Csi32/UX14Csi32

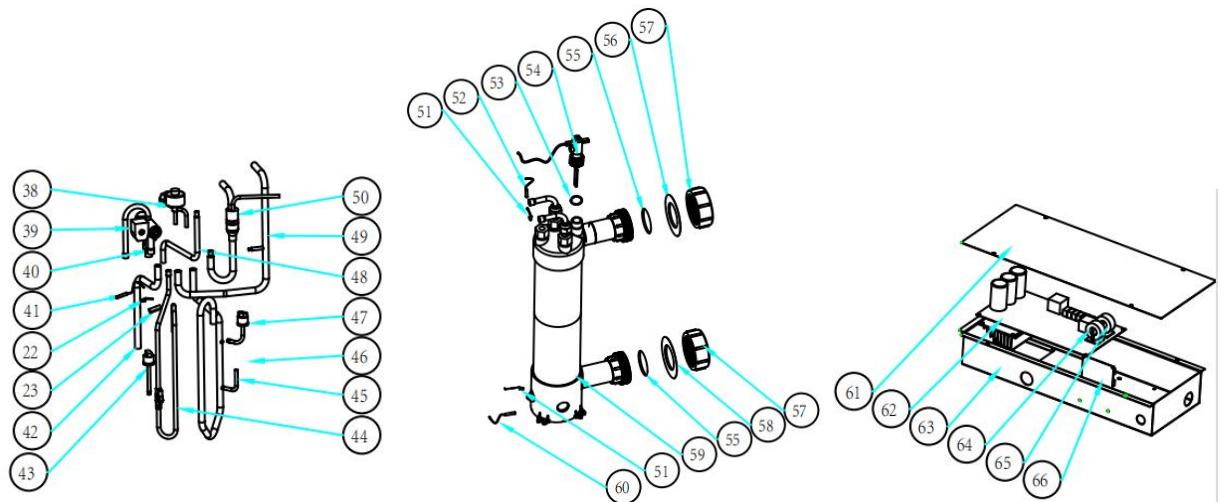
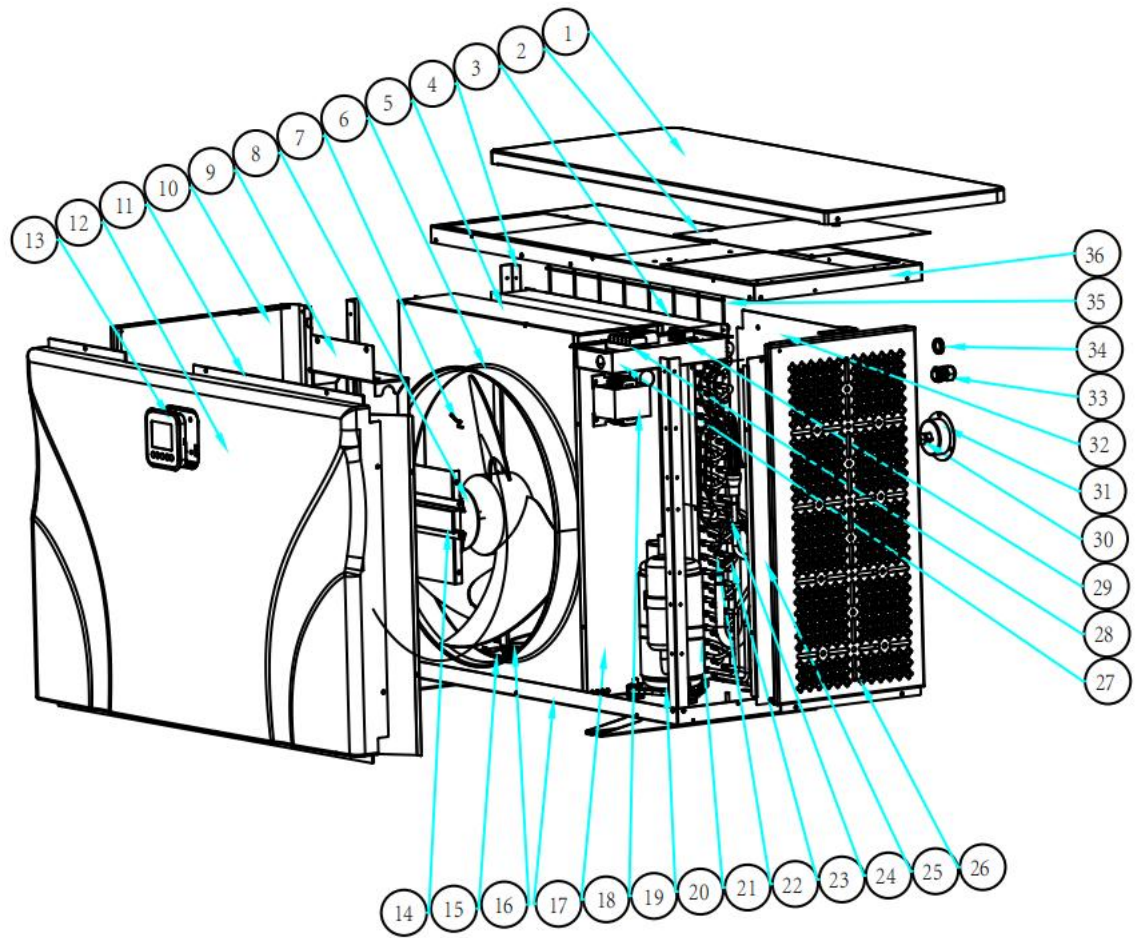

## UX11Csi32

NO.	ERP	Part name	NO.	ERP	Part name
1	109060056	Obere Abdeckung	34	136020119	Kabelverbinder
2	109060053	Service-Panel	35	109060017	Hinterer Grill
3	103000335	Verdampfer	36	109060051	Oberer Rahmen
4	109060052	Säule	37	119000058	EEV
5	109060023	Lüfterpanel	38	121000037	4-Wege-Ventilspule
6	117110063	Umgebungstemparatursensor T5-TH1	39	121000034	4 Wege Ventil
7	132000015	Ventilatorflügel	40	117110050	Verdampfertemperatursensor T3-TH2
8	112000031	Lüftermotor	41	113060188	Rohr
9	109060027	Lüfter Motorhalterung	42	116000066	Hochdruckschalter
10	109060058	Linkes Feld	43	113020623	Rohr
11	109060042	Service-Panel	44	113020579	Rohr
12	133470001	Frontblende	45	/	Rohr
13	117020293	Display	46	116000071	Niederdruckschalter
14	109060054	Säule	47	113080123	Rohr
15	109060004	Verdampferplatte	48	113030214	Rohr
16	142000142	Verdampferheizwiderstand	49	113070067	Rohr
17	109060050	Bodenschale	50	108010025	Clip
18	109060059	Isolierungsplatte	51	117110057	Wasseraustrittstemperatursensor T2-TH5
19	117230003	Elektrischer Reaktor	52	136010072	Dichtungsring
20	101000188	Kompressor	53	116000103	Strömungswächter
21	142000072	Kompressorheizwiderstand	54	133020007	PVC-Abdeckung
22	113190007	Clip	55	133020012	Roter Gummiring
23	113190001	Sensorhalter	56	102050004	Wasserverbindung
24	117110061	Entladetemperatursensor T6-TH3	57	133020012	Roter Gummiring
25	109060044	Service-Panel	58	102041113	Titan-Wärmetauscher
26	109060057	Rechtes Feld	59	117110053	Wassereintrittstemperatursensor T1-TH6
27	108960058	Anschlusskasten	60	109060007	Schaltkastenabdeckung
28	115000004	Anschlussklemme	61	117100079	PCB
29	136010004	Clip	62	109060039	Schaltkasten
30	124020011	Schraube	63	117240002	Magnetring
31	106000012	Druckanzeige	64	117240003	Magnetring
32	109060055	RückWand	65	117010122	Wifi-Modul
33	110000039	Kabelverbinder			



## UX14Csi32

NO.	ERP	Part name	NO.	ERP	Part name
1	109060056	Obere Abdeckung	34	136020119	Kabelverbinder
2	109060053	Service-Panel	35	109060017	Hinterer Grill
3	103000335	Verdampfer	36	109060051	Oberer Rahmen
4	109060052	Säule	37	119000058	EEV
5	109060023	Lüfterpanel	38	121000037	4-Wege-Ventilspule
6	117110063	Umgebungstemparatursensor T5-TH1	39	121000034	4 Wege Ventil
7	132000015	Ventilatorflügel	40	117110050	Verdampfertemperatursensor T3-TH2
8	112000031	Lüftermotor	41	113060188	Rohr
9	109060027	Lüfter Motorhalterung	42	116000066	Hochdruckschalter
10	109060058	Linkes Feld	43	113020623	Rohr
11	109060042	Service-Panel	44	113020693	Rohr
12	133470001	Frontblende	45	/	Rohr
13	117020293	Display	46	116000071	Niederdruckschalter
14	109060054	Säule	47	113080123	Rohr
15	109060004	Verdampferplatte	48	113030214	Rohr
16	142000142	Verdampferheizwiderstand	49	113070067	Rohr
17	109060050	Bodenschale	50	108010025	Clip
18	109060059	Isolierungsplatte	51	117110057	Wasseraustrittstemperatursensor T2-TH5
19	117230003	Elektrischer Reaktor	52	136010072	Dichtungsring
20	101000188	Kompressor	53	116000103	Strömungswächter
21	142000072	Kompressorheizwiderstand	54	133020007	PVC-Abdeckung
22	113190007	Clip	55	133020012	Roter Gummiring
23	113190001	Sensorhalter	56	102050004	Wasserverbindung
24	117110061	Entladetemperatursensor T6-TH3	57	133020012	Roter Gummiring
25	109060044	Service-Panel	58	102041138	Titan-Wärmetauscher
26	109060057	Rechtes Feld	59	117110053	Wassereintrittstemperatursensor T1-TH6
27	108960058	Anschlusskasten	60	109060007	Schaltkastenabdeckung
28	115000004	Anschlussklemme	61	117100076	PCB
29	136010004	Clip	62	109060039	Schaltkasten
30	124020011	Schraube	63	117240002	Magnetring
31	106000012	Druckanzeige	64	117240003	Magnetring
32	109060055	RückWand	65	117010122	Wifi-Modul
33	110000039	Kabelverbinder			

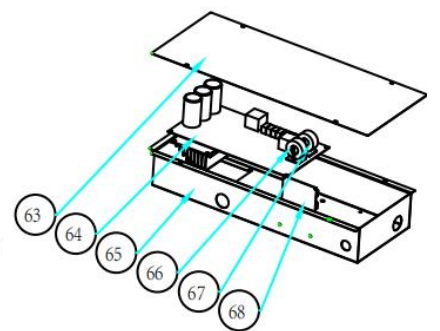
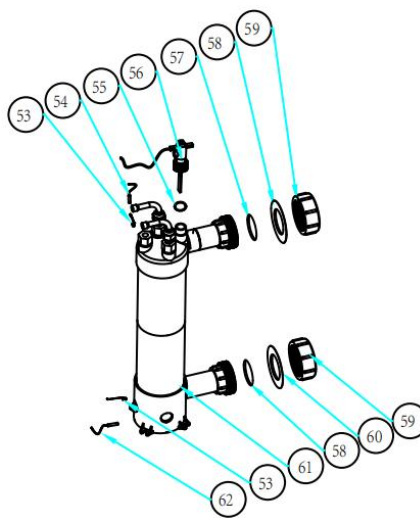
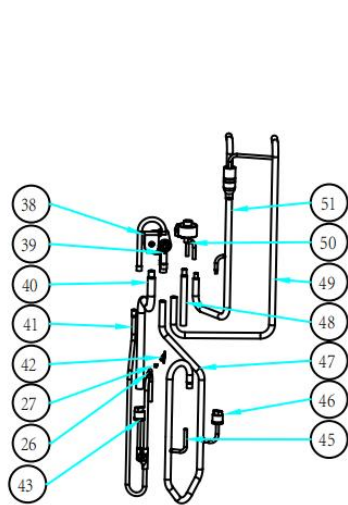
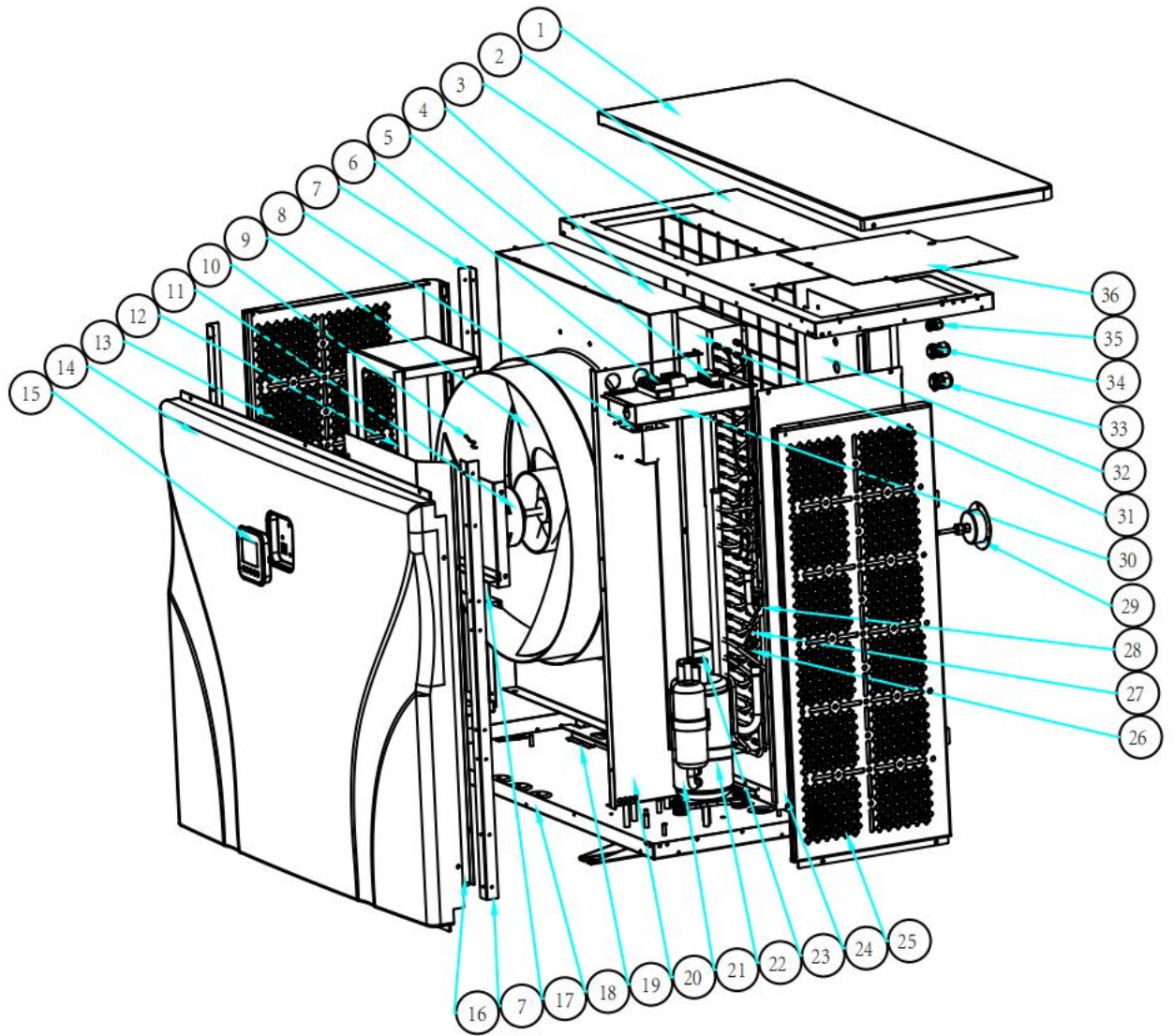

**UX17Csi32**

NO.	ERP	Part name	NO.	ERP	Part name
1	108960050	Obere Abdeckung	35	110000036	Kabelverbinder
2	108960057	Oberer Rahmen	36	108960053	Service-Panel
3	108840091	Hinterer Grill	37	/	/
4	108960061	Lüfterpanel	38	121000037	4-Wege-Ventilspule
5	136010004	Clip	39	121000034	4 Wege Ventil
6	115000004	Anschlussklemme	40	113060208	Rohr
7	108960037	Säule	41	113010440	Rohr
8	117230003	Elektrischer Reaktor	42	117110050	Verdampfer Temperatursensor T3-TH2
9	132000023	Ventilatorflügel	43	116000067	Hochdruckschalter
10	112000031	Lüftermotor	44	/	/
11	117110063	Umgebungstemperatursensor T5-TH1	45	/	Rohr
12	108960060	Lüfter Motorhalterung	46	116000073	Niederdruckschalter
13	108960073	Linkes Feld	47	113020673	Rohr
14	133450001	Frontblende	48	113080128	Rohr
15	117020293	Display	49	113030212	Rohr
16	108960062	Service-Panel	50	119000058	EEV
17	108960052	Säule	51	113070065	Rohr
18	108960074	Bodenschale	52		#N/A
19	108960002	Verdampferplatte	53	108010025	Clip
20	108960063	Isolierungsplatte	54	117110057	Wasseraustrittstemperatursensor T2-TH5
21	101000181	Kompressor	55	136010072	Dichtungsring
22	142000074	Kompressorheizwiderstand	56	116000065	Strömungswächter
23	142000142	Verdampferheizwiderstand	57	133020007	PVC-Abdeckung
24	108960065	Service-Panel	58	133020012	Roter Gummiring
25	108960072	Rechtes Feld	59	102050004	Wasserverbindung
26	113190001	Sensorhalter	60	133020011	Blauer Gummiring
27	113190007	Clip	61	102041110	Titan-Wärmetauscher
28	117110061	Entladetemperatursensor T6-TH3	62	117110053	Wassereintrittstemperatursensor T1-TH6
29	106000012	Druckanzeige	63	108960007	Schaltkastenabdeckung
30	108960058	Anschlusskasten	64	117100076	PCB
31	103000360	Verdampfer	65	108960054	Schaltkasten
32	108960075	RückWand	66	117240002	Magnetring
33	110000048	Kabelverbinder	67	117240003	Magnetring
34	110000039	Kabelverbinder	68	117010122	Wifi-Modul

**UX21Csi32**

NO.	ERP	Part name	NO.	ERP	Part name
1	108960050	Obere Abdeckung	35	110000036	Kabelverbinder
2	108960057	Oberer Rahmen	36	108960053	Service-Panel
3	108840091	Hinterer Grill	37	121000028	4 Wege Ventil
4	108960061	Lüfterpanel	38	121000037	4-Wege-Ventilspule
5	136010004	Clip	39	119000066	EEV
6	115000004	Anschlussklemme	40	113080128	Rohr
7	108960037	Säule	41	113060193	Rohr
8	117230003	Elektrischer Reaktor	42	116000068	Hochdruckschalter
9	132000023	Ventilatorflügel	43	117110050	Verdampfer temperatursensor T3-TH2
10	112000031	Lüftermotor	44	113010434	Rohr
11	117110063	Umgebungstemperatursensor T5-TH1	45	105000004	Flüssigkeitsvorratsbehälter
12	108960060	Lüfter Motorhalterung	46	113020683	Rohr
13	108960073	Linkes Feld	47	113130041	Rohr
14	133450001	Frontblende	48	116000073	Niederdruckschalter
15	117020293	Display	49	113120065	Rohr
16	108960062	Service-Panel	50	113030216	Rohr
17	108960052	Säule	51	120000066	Dörrfilter
18	108960079	Bodenschale	52	113170079	Rohr
19	108960002	Verdampferplatte	53	108010025	Clip
20	108960063	Isolierungsplatte	54	117110057	Wasseraustrittstemperatursensor T2-TH5
21	101000252	Kompressor	55	136010072	Dichtungsring
22	142000072	Kompressorheizwiderstand	56	116000065	Strömungswächter
23	142000142	Verdampferheizwiderstand	57	133020007	PVC-Abdeckung
24	108960065	Service-Panel	58	133020012	Roter Gummiring
25	108960072	Rechtes Feld	59	102050004	Wasserverbindung
26	113190001	Sensorhalter	60	133020011	Blauer Gummiring
27	113190007	Clip	61	102041110	Titan-Wärmetauscher
28	117110061	Entladetemperatursensor T6-TH3	62	117110053	Wassereintrittstemperatursensor T1-TH6
29	106000012	Druckanzeige	63	108960007	Schaltkastenabdeckung
30	108960058	Anschlusskasten	64	117100076	PCB
31	103000337	Verdampfer	65	108960054	Schaltkasten
32	108960075	Rückwand	66	117240002	Magnetring
33	110000048	Kabelverbinder	67	117240003	Magnetring
34	110000039	Kabelverbinder	68	117010122	Wifi-Modul

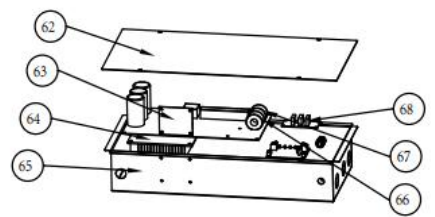
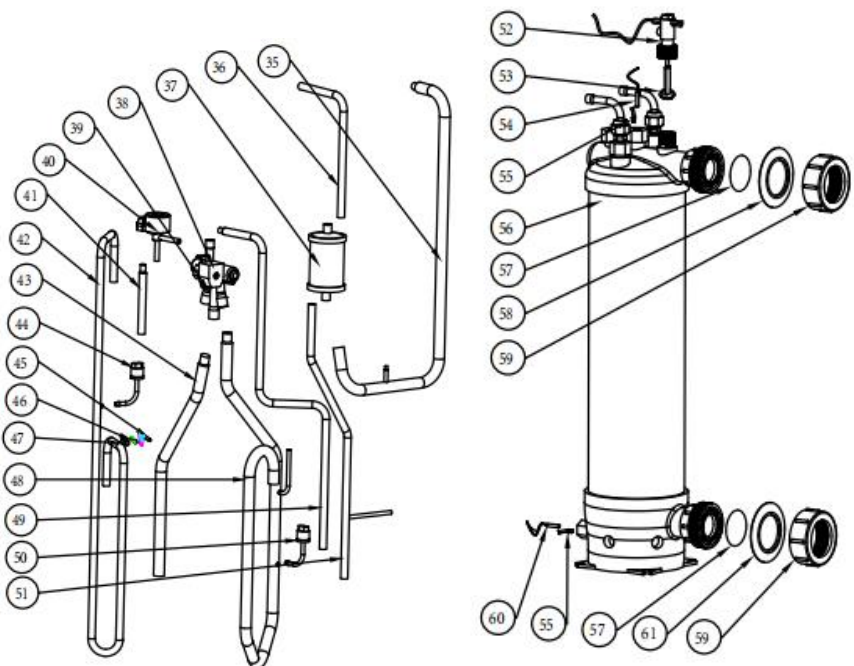
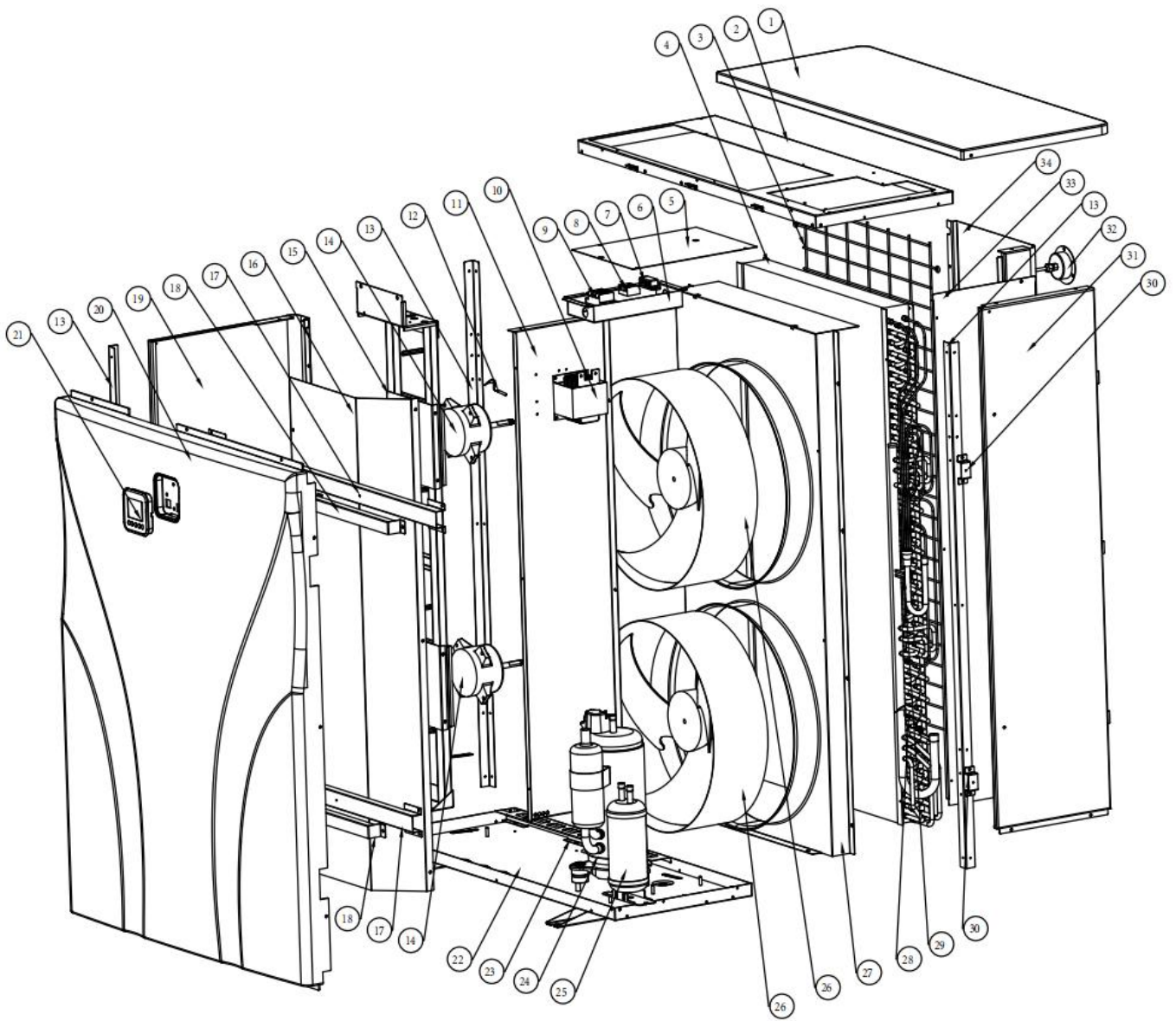

**UX26Csi32**

NO.	ERP	Part name	NO.	ERP	Part name
1	108940051	Obere Abdeckung	35	113030215	Rohr
2	108940059	Oberer Rahmen	36	113170078	Rohr
3	108940012	Hinterer Grill	37	120000066	Dörrfilter
4	103000354	Verdampfer	38	121000037	4-Wege-Ventilspule
5	108940034	Service-Panel	39	121000028	4 Wege Ventil
6	108960058	Anschlusskasten	40	119000059	EEV
7	136010004	Clip	41	113080116	Rohr
8	115000012	Anschlussklemme	42	113020621	Rohr
9	115000025	Anschlussklemme	43	113060211	Rohr
10	117230002	Elektrischer Reaktor	44	116000068	Hochdruckschalter
11	108940060	Isolierungsplatte	45	117110051	Entladetemperatursensor T6-TH3
12	117110063	Umgebungstemperatursensor T5-TH1	46	113190007	Clip
13	108940047	Säule	47	113190001	Sensorhalter
14	112000031	Lüftermotor	48	113020703	Rohr
15	108940016	Lüfter Motorhalterung	49	113130040	Rohr
16	108940035	Service-Panel	50	116000073	Niederdruckschalter
17	108940048	Säule	51	113120063	Rohr
18	108960081	Säule	52	116000065	Strömungswächter
19	108940057	Linkes Feld	53	136010089	Dichtungsring
20	133480002	Frontblende	54	117110057	Wasseraustrittstemperatursensor T2-TH5
21	117020293	Display	55	108010025	Clip
22	108940043	Bodenschale	56	102041127	Titan-Wärmetauscher
23	108940004	Verdampferplatte	57	133020007	PVC-Abdeckung
24	101000185	Kompressor	58	133020012	Roter Gummiring
25	105000015	Flüssigkeitsvorratsbehälter	59	102050004	Wasserverbindung
26	132000015	Ventilatorflügel	60	117110053	Wassereintrittstemperatursensor T1-TH6
27	108940056	Lüfterpanel	61	133020011	Blauer Gummiring
28	117110050	Verdampfertemperatursensor T3-TH2	62	108940062	Schaltkastenabdeckung
29	136020005	Gummiblock	63	117010122	Wifi-Modul
30	109070064	Säule	64	117100077	PCB
31	108940058	Rechtes Feld	65	108940061	Schaltkasten
32	106000012	Druckanzeige	66	117240002	Magnetring
33	108940036	Service-Panel	67	117240003	Magnetring
34	108940053	Rückwand	68	117010081	Clip

UX30Csi32/UX30Csi32T/UX35Csi32T

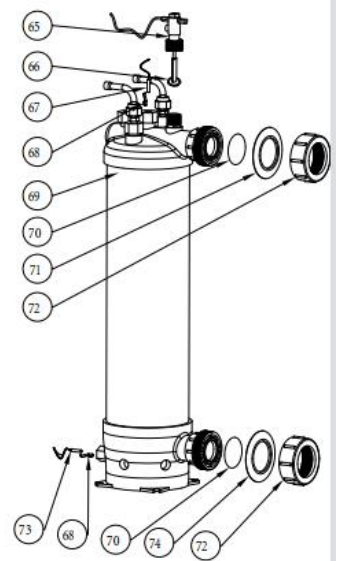
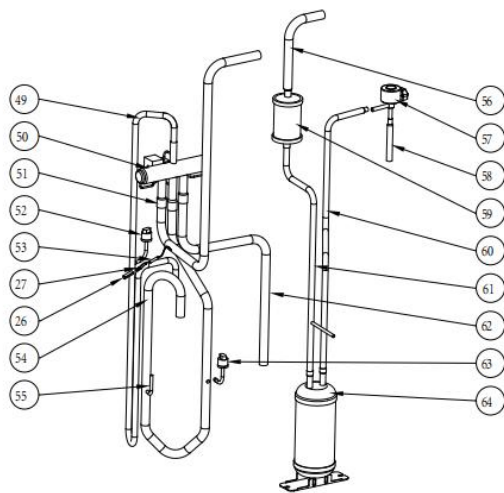
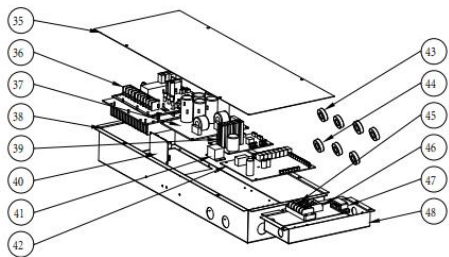
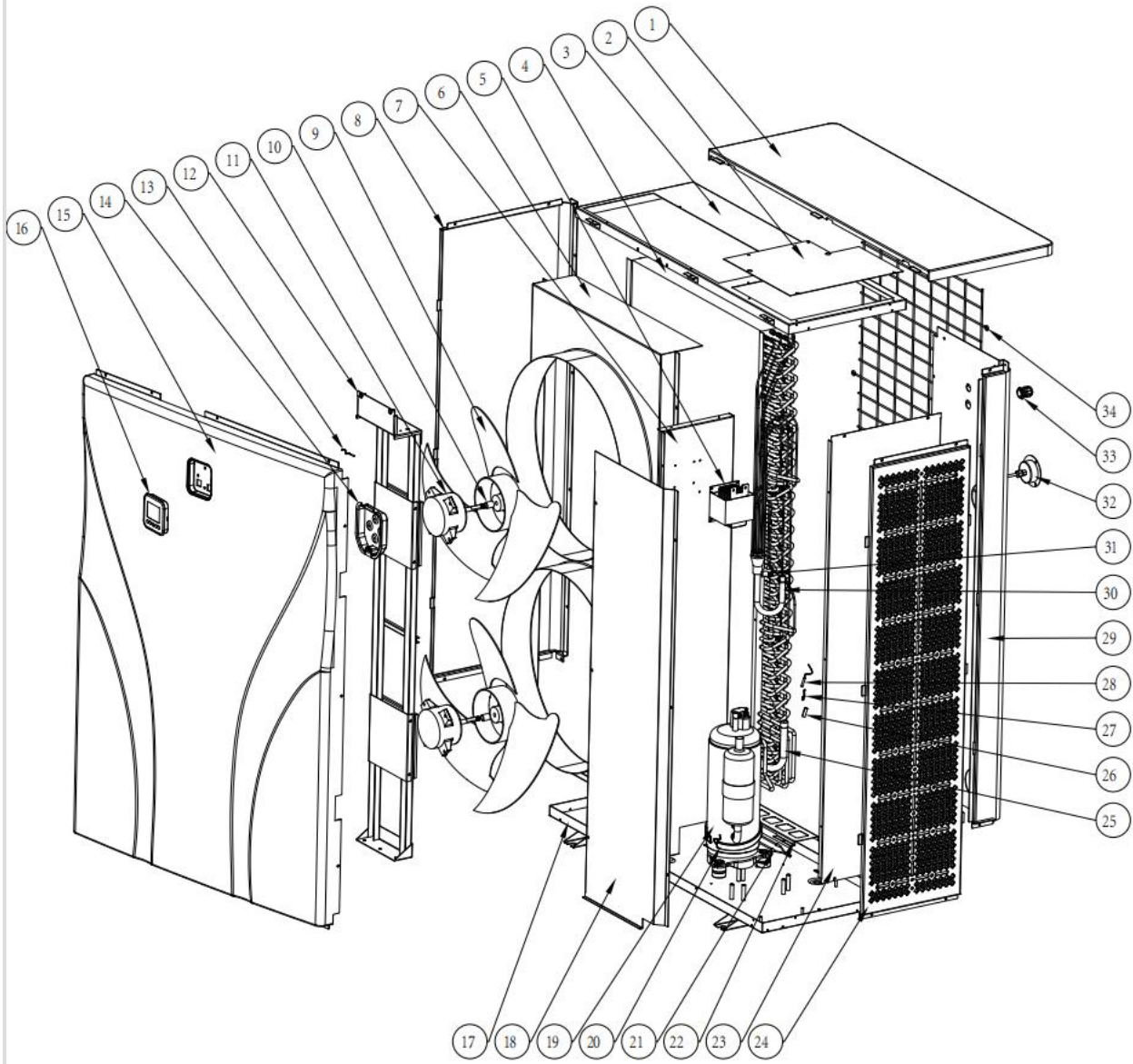

**UX30Csi32**

NO.	ERP	Part name	NO.	ERP	Part name
1	109070060	Obere Abdeckung	38	109070006	Schaltkasten
2	109070052	Service-Panel	39	/	/
3	109070051	Oberer Rahmen	40	117010122	Wifi-Modul
4	103000331	Verdampfer	41	142000038	Relais
5	117230002	Elektrischer Reaktor	42	117250021	PCB
6	109070019	Lüfterpanel	43	117240002	Magnetring
7	109070026	Isolierungsplatte	44	117240003	Magnetring
8	109070057	Linkes Feld	45	115000025	Anschlussklemme
9	132000023	Ventilatorflügel	46	115000023	Anschlussklemme
10	108010024	Lüftermotorbaugruppe	47	136010004	Clip
11	112000031	Lüftermotor	48	108960058	Anschlusskasten
12	109070021	Lüfter Motorhalterung	49	113010444	Rohr
13	117110063	Umgebungstempersensord T5-TH1	50	121000028	4 Wege Ventil
14	133030020	Steuergerät-Box	51	113030183	Rohr
15	133460001	Frontblende	52	116000068	Hochdruckschalter
16	117020293	Display	53	117110051	Entladetempersensord T6-TH3
17	109070065	Bodenschale	54	113020684	Rohr
18	109070053	Service-Panel	55	113020685	Rohr
19	101000185	Kompressor	56	113070061	Rohr
20	142000077	Kompressorheizwiderstand	57	119000061	EEV
21	142000079	Verdampferheizwiderstand	58	113080116	Rohr
22	109070004	Verdampferplatte	59	120000066	Dörrfilter
23	109070054	Service-Panel	60	113120053	Rohr
24	109070058	Rechtes Feld	61	113130039	Rohr
25	103000331	Rohr	62	113060214	Rohr
26	113190001	Sensorhalter	63	116000073	Niederdruckschalter
27	113190007	Clip	64	105000015	Flüssigkeitsvorratsbehälter
28	117110050	Verdampfertempersensord T3-TH2	65	116000065	Strömungswächter
29	109070062	RückWand	66	136020083	Dichtungsring
30	103000331	Rohr	67	117110057	Wasseraustrittstempersensord T2-TH5
31	136020005	Gummiblock	68	108010025	Clip
32	106000012	Druckanzeige	69	102041106	Titan-Wärmetauscher
33	110000038	Kabelverbinder	70	133020006	Gummiring am Wasseranschluss
34	109070022	Hinterer Grill	71	133020012	Roter Gummiring
35	109070007	Schaltkastenabdeckung	72	102050004	Wasserverbindung
36	117140016	Treiberplatine	73	117110053	Wassereintrittstempersensord T1-TH6
37	117260001	Filterplatine	74	133020011	Blauer Gummiring



**UX30Csi32T**

NO.	ERP	Part name	NO.	ERP	Part name
1	109070060	Obere Abdeckung	38	109070006	Schaltkasten
2	109070052	Service-Panel	39	/	/
3	109070051	Oberer Rahmen	40	117010122	Wifi-Modul
4	103000331	Verdampfer	41	142000038	Relais
5	117230002	Elektrischer Reaktor	42	117250022	PCB
6	109070019	Lüfterpanel	43	117240002	Magnetring
7	109070068	Isolierungsplatte	44	117240003	Magnetring
8	109070070	Linkes Feld	45	115000006	Anschlussklemme
9	132000023	Ventilatorflügel	46	115000023	Anschlussklemme
10	108010024	Lüftermotorbaugruppe	47	136010004	Clip
11	112000031	Lüftermotor	48	108960058	Anschlusskasten
12	109070021	Lüfter Motorhalterung	49	113020636	Rohr
13	117110063	Umgebungstempatursensor T5-TH1	50	121000028	4 Wege Ventil
14	133030020	Steuergerät-Box	51	113030183	Rohr
15	133460001	Frontblende	52	116000068	Hochdruckschalter
16	117020293	Display	53	117110051	Entladetempatursensor T6-TH3
17	180060001	Bodenschale	54	113020697	Rohr
18	109070069	Service-Panel	55	/	Rohr
19	101000239	Kompressor	56	113070061	Rohr
20	142000077	Kompressorheizwiderstand	57	119000061	EEV
21	142000079	Verdampferheizwiderstand	58	113080116	Rohr
22	109070004	Verdampferplatte	59	120000066	Dörrfilter
23	109070066	Service-Panel	60	113120053	Rohr
24	109070058	Rechtes Feld	61	113130039	Rohr
25	103000331	Rohr	62	113060214	Rohr
26	113190001	Sensorhalter	63	116000073	Niederdruckschalter
27	113190007	Clip	64	105000015	Flüssigkeitsvorratsbehälter
28	117110050	Verdampfertempatursensor T3-TH2	65	116000065	Strömungswächter
29	109070062	RückWand	66	136020083	Dichtungsring
30	103000331	Rohr	67	117110057	Wasseraustrittstempatursensor T2-TH5
31	136020005	Gummiblock	68	108010025	Clip
32	106000012	Druckanzeige	69	102041106	Titan-Wärmetauscher
33	110000038	Kabelverbinder	70	133020006	Gummiring am Wasseranschluss
34	109070022	Hinterer Grill	71	133020012	Roter Gummiring
35	109070007	Schaltkastenabdeckung	72	102050004	Wasserverbindung
36	117140019	Treiberplatine	73	117110053	Wassereintrittstempatursensor T1-TH6
37	117260002	Filterplatine	74	133020011	Blauer Gummiring

**UX35Csi32T**

NO.	ERP	Part name	NO.	ERP	Part name
1	109070060	Obere Abdeckung	38	109070006	Schaltkasten
2	109070052	Service-Panel	39	/	/
3	109070051	Oberer Rahmen	40	117010122	Wifi-Modul
4	103000356	Verdampfer	41	142000038	Relais
5	117230002	Elektrischer Reaktor	42	117250022	PCB
6	109070019	Lüfterpanel	43	117240002	Magnetring
7	109070068	Isolierungsplatte	44	117240003	Magnetring
8	109070070	Linkes Feld	45	115000006	Anschlussklemme
9	132000023	Ventilatorflügel	46	115000023	Anschlussklemme
10	108010024	Lüftermotorbaugruppe	47	136010004	Clip
11	112000031	Lüftermotor	48	108960058	Anschlusskasten
12	109070021	Lüfter Motorhalterung	49	113020636	Rohr
13	117110063	Umgebungstempersensord T5-TH1	50	121000028	4 Wege Ventil
14	133030020	Steuergerät-Box	51	113030183	Rohr
15	133460001	Frontblende	52	116000068	Hochdruckschalter
16	117020293	Display	53	117110051	Entladetempersensord T6-TH3
17	180060001	Bodenschale	54	113020697	Rohr
18	109070069	Service-Panel	55	/	Rohr
19	101000239	Kompressor	56	113070061	Rohr
20	142000077	Kompressorheizwiderstand	57	119000061	EEV
21	142000079	Verdampferheizwiderstand	58	113080116	Rohr
22	109070004	Verdampferplatte	59	120000066	Dörrfilter
23	109070066	Service-Panel	60	113120053	Rohr
24	109070058	Rechtes Feld	61	113130039	Rohr
25	103000356	Rohr	62	113060214	Rohr
26	113190001	Sensorhalter	63	116000073	Niederdruckschalter
27	113190007	Clip	64	105000015	Flüssigkeitsvorratsbehälter
28	117110050	Verdampfertempersensord T3-TH2	65	116000065	Strömungswächter
29	109070062	RückWand	66	136020083	Dichtungsring
30	103000356	Rohr	67	117110057	Wasseraustrittstempersensord T2-TH5
31	136020005	Gummiblock	68	108010025	Clip
32	106000012	Druckanzeige	69	102041106	Titan-Wärmetauscher
33	110000038	Kabelverbinder	70	133020006	Gummiring am Wasseranschluss
34	109070022	Hinterer Grill	71	133020012	Roter Gummiring
35	109070007	Schaltkastenabdeckung	72	102050004	Wasserverbindung
36	117140019	Treiberplatine	73	117110053	Wassereintrittstempersensord T1-TH6
37	117260002	Filterplatine	74	133020011	Blauer Gummiring

**Swimming Pool Heat Pump  
User and Service Manual**

**INVERBOOST INVERTER**

# Regulation (EU) n° 517/2014 of 16/04/14 on fluorinated greenhouse gases and repealing Regulation (EC) n° 842/2006

---

## Leak checks

1. Operators of equipment that contains fluorinated greenhouse gases in quantities of 5 tons of CO<sub>2</sub>, equivalent or more and not contained in foams shall ensure that the equipment is checked for leaks.
2. For equipment that contains fluorinated greenhouse gases in quantities of 5 tons of CO<sub>2</sub> equivalent or more, but of less than 50 tons of CO<sub>2</sub> equivalent: at least every 12 months.

## Picture of the equivalence CO<sub>2</sub>

1. Load in kg and Tons amounting CO<sub>2</sub>.

Load and Tons amounting CO <sub>2</sub>	Frequency of test
From 7 at 75 kg load = from 5 at 50 Tons	Each year

Concerning the Gas R32, 7.40kg amounting at 5 tons of CO<sub>2</sub>, commitment to check each year.

## Training and certification

1. The operator of the relevant application shall ensure that the relevant personnel have obtained the necessary certification, which implies appropriate knowledge of the applicable regulations and standards as well as the necessary competence in emission prevention and recovery of fluorinated greenhouse gases and handling safety the relevant type and size of equipment.

## Record keeping

1. Operators of equipment which is required to be checked for leaks, shall establish and maintain records for each piece of such equipment specifying the following information:
  - a) The quantity and type of fluorinated greenhouse gases installed;
  - b) The quantities of fluorinated greenhouse gases added during installation, maintenance or servicing or due to leakage;
  - c) Whether the quantities of installed fluorinated greenhouse gases have been recycled or reclaimed, including the name and address of the recycling or reclamation facility and, where applicable, the certificate number;
  - d) The quantity of fluorinated greenhouse gases recovered
  - e) The identity of the undertaking which installed, serviced, maintained and where applicable repaired or decommissioned the equipment, including, where applicable, the number of its certificate;
  - f) The dates and results of the checks carried out;
  - g) If the equipment was decommissioned, the measures taken to recover and dispose of the fluorinated greenhouse gases.
2. The operator shall keep the records for at least five years, undertakings carrying out the activities for operators shall keep copies of the records for at least five years.

## INDEX

1. Specifications
2. Dimension
3. Installation and Connection
4. Adjust the by-pass Kit
5. Display Controller Operation
6. Malfunction and Trouble Shooting
7. Electrical Wiring
8. Maintenance
9. Exploded View

Thank you for using INVERBOOST INVERTER swimming pool heat pump for your pool heating, it will heat your pool water and keep the constant temperature when the air ambient temperature is at -20 to 43°C.

 **ATTENTION:** This manual includes all the necessary information with the use and the installation of your heat pump.

The installer must read the manual and attentively follow the instructions in implementation and maintenance.

The installer is responsible for the installation of the product and should follow all the instructions of the manufacturer and the regulations in application. Incorrect installation against the manual implies the exclusion of the entire guarantee.

The manufacturer declines any responsibility for the damage caused with the people, objects and of the errors due to the installation that disobey the manual guideline. Any use that is without conformity at the origin of its manufacturing will be regarded as dangerous.

**WARNING:** Please always empty the water in heat pump during winter time or when the ambient temperature drops below 0°C, or else the Titanium exchanger will be damaged because of being frozen, in such case, your warranty will be lost.

**WARNING:** Please always cut the power supply if you want to open the cabinet to reach inside the heat pump, because there is high voltage electricity inside.

**WARNING:** Please well keep the display controller in a dry area, or well close the insulation cover to protect the display controller from being damaged by humidity.

# 1. Specification

Model		UX11Csi32	UX14Csi32	UX17Csi32
<b>* Performance at Air 28°C, Water 28°C, Humidity 80%</b>				
Turbo Heating Capacity	kW	11.0	14.0	17.0
Smart Heating Capacity	kW	10.0	11.0	14.0
Power consumption	kW	1.55-0.17	1.97-0.22	2.39-0.27
C.O.P.		16-7.4	16-7.1	16-7.2
C.O.P. in Turbo Mode		7.4	7.1	7.2
C.O.P. at 50% capacity		11.8	11.0	11.8
<b>* Performance at Air 15°C, Water 26°C, Humidity 70%</b>				
Turbo Heating Capacity	kW	8.5	9.5	12.0
Smart Heating Capacity	kW	7.0	8.0	10.5
Power consumption	kW	1.67-0.26	1.90-0.29	2.31-0.37
C.O.P.		8.2-5.1	8.21-5	8.5-5.2
C.O.P. in Turbo Mode		5.1	5.0	5.2
C.O.P. at 50% capacity		7.1	7.0	7.8
<b>*General Date</b>				
Compressor type		Inverter compressor		
Voltage		220-240V/50Hz/1PH		
Rated current	A	6.9	8.7	10.6
Max current	A	10.5	13.5	15.5
Minimum fuse	A	12.0	15.0	16.0
Advised water flux	m <sup>3</sup> /h	3.7	4.0	5.0
Water pressure drop	Kpa	12.0	14.0	15.0
Heat exchanger		Twist Titanium exchanger		
Water connection	mm	50		
Fan quantity		1		
Ventilation type		Horizontal		
Noise level(10m)	dB(A)	17.8-26.2	21.7-26.7	22.6-28.1
Noise level(1m)	dB(A)	36-46.2	38-47.6	39.5-49.8
<b>* Dimension/ Weight</b>				
Net weight	kg	73	78	98
Gross weight	kg	78	83	113
Net dimension	mm	1028*441*685	1028*441*685	1073*492*886
Packing dimension	mm	1095*525*830	1095*525*830	1140*555*1030

Model		UX21Csi32	UX26Csi32	UX30Csi32
<b>* Performance at Air 28°C, Water 28°C, Humidity 80%</b>				
Turbo Heating Capacity	kW	21.0	26.0	30.0
Smart Heating Capacity	kW	18.0	21.0	25.0
Power consumption	kW	2.96-0.33	3.66-0.29	4.17-0.47
C.O.P.		16-7.1	16-7.1	16-7.1
C.O.P. in Turbo Mode		7.1	7.1	7.1
C.O.P. at 50% capacity		11.2	11.2	11.2
<b>* Performance at Air 15°C, Water 26°C, Humidity 70%</b>				
Turbo Heating Capacity	kW	15.5	18.0	20.0
Smart Heating Capacity	kW	13.5	16.0	18.0
Power consumption	kW	3.04-0.47	3.53-0.55	3.92-0.61
C.O.P.		8.3-5.1	8.2-5.1	8.2-5.1
C.O.P. in Turbo Mode		5.1	5.1	5.1
C.O.P. at 50% capacity		7.4	7.2	7.2
<b>*General Date</b>				
Compressor type		Inverter compressor		
Voltage		220-240V/50Hz/1PH		
Rated current	A	13.1	16.3	18.5
Max current	A	19.5	24.0	28.0
Minimum fuse	A	22	28	32
Advised water flux	m <sup>3</sup> /h	6.0	8.0	10.0
Water pressure drop	Kpa	15	18	20
Heat exchanger		Twist Titanium exchanger		
Water connection	mm	50		
Fan quantity		1	2	2
Ventilation type		Horizontal		
Noise level(10m)	dB(A)	22.9-30.6	23.1-31.8	23.2-32.4
Noise level(1m)	dB(A)	40-51	41-51.6	42-51.8
<b>* Dimension/ Weight</b>				
Net weight	kg	117	125	130
Gross weight	kg	135	145	148
Net dimension	mm	1073*492*886	1039*509*1289	1113*519*1410
Packing dimension	mm	1185*530*1030	1185*565*1435	1225*540*1555

Model		UX30Csi32T	UX35Csi32T
<b>* Performance at Air 28°C, Water 28°C, Humidity 80%</b>			
Turbo Heating Capacity	kW	30.0	35.0
Smart Heating Capacity	kW	25.0	30.0
Power consumption	kW	4.17-0.47	4.93-0.55
C.O.P.		16-7.1	16-7.1
C.O.P. in Turbo Mode		7.1	7.1
C.O.P. at 50% capacity		11.2	11.2
<b>* Performance at Air 15°C, Water 26°C, Humidity 70%</b>			
Turbo Heating Capacity	kW	20.0	24.0
Smart Heating Capacity	kW	18.0	22.0
Power consumption	kW	3.85-0.61	4.62-0.73
C.O.P.		8.2-5.2	8.2-5.2
C.O.P. in Turbo Mode		5.2	5.2
C.O.P. at 50% capacity		7.2	7.2
<b>*General Date</b>			
Compressor type		Inverter compressor	
Voltage		380V/50Hz/3PH	
Rated current	A	7.5	8.8
Max current	A	12.0	14.0
Minimum fuse	A	15	17
Advised water flux	m <sup>3</sup> /h	10.0	15.0
Water pressure drop	Kpa	20	25
Heat exchanger		Twist Titanium exchanger	
Water connection	mm	50	
Fan quantity		2	2
Ventilation type		Horizontal	
Noise level(10m)	dB(A)	23.2-32.4	23.4-32.8
Noise level(1m)	dB(A)	42-51.8	42.8-52
<b>* Dimension/ Weight</b>			
Net weight	kg	130	135
Gross weight	kg	148	150
Net dimension	mm	1113*519*1410	1113*519*1410
Packing dimension	mm	1225*540*1555	1225*540*1555

\* Above data may be modified without notice.



## 2. Dimension

UX11Csi32/UX14Csi32

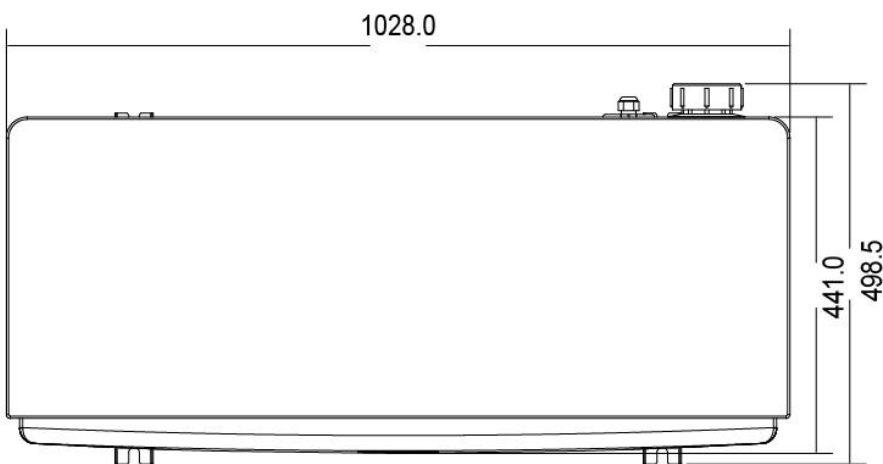
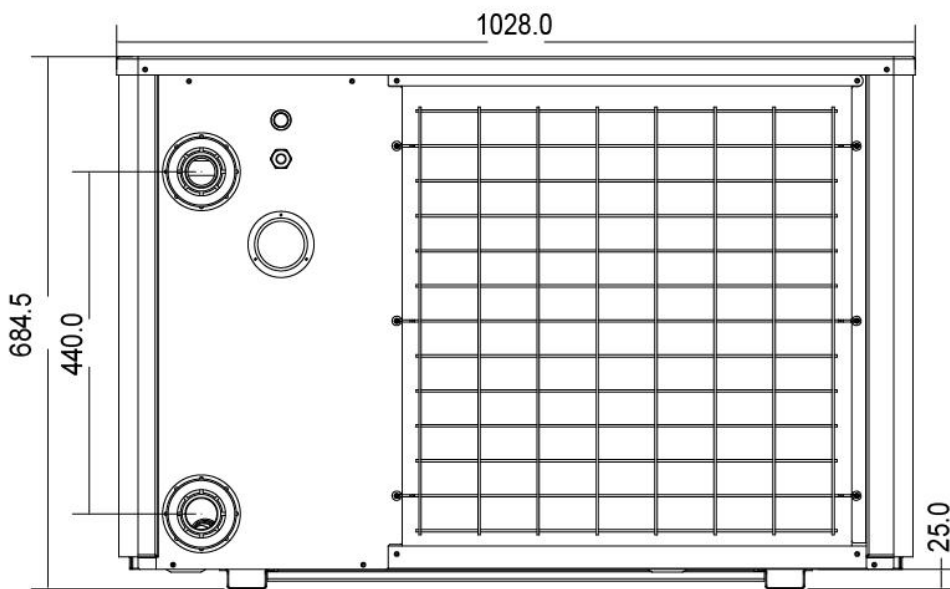
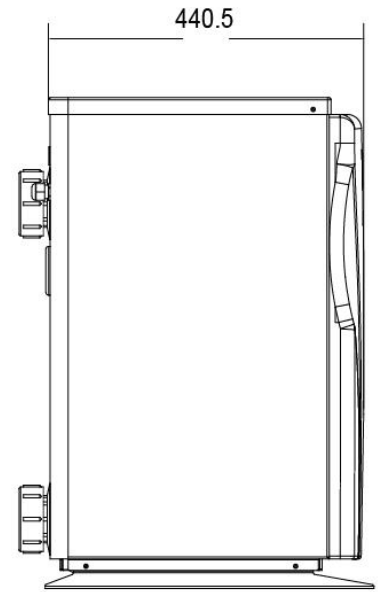
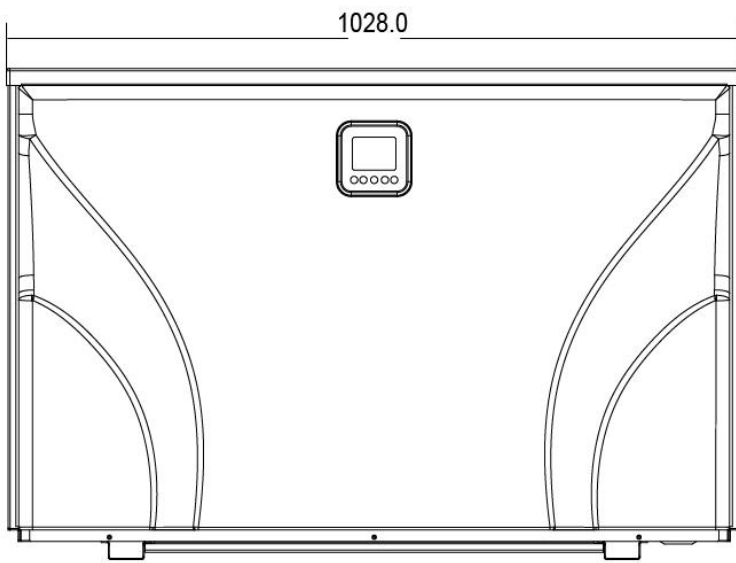

UX17Csi32/UX21Csi32

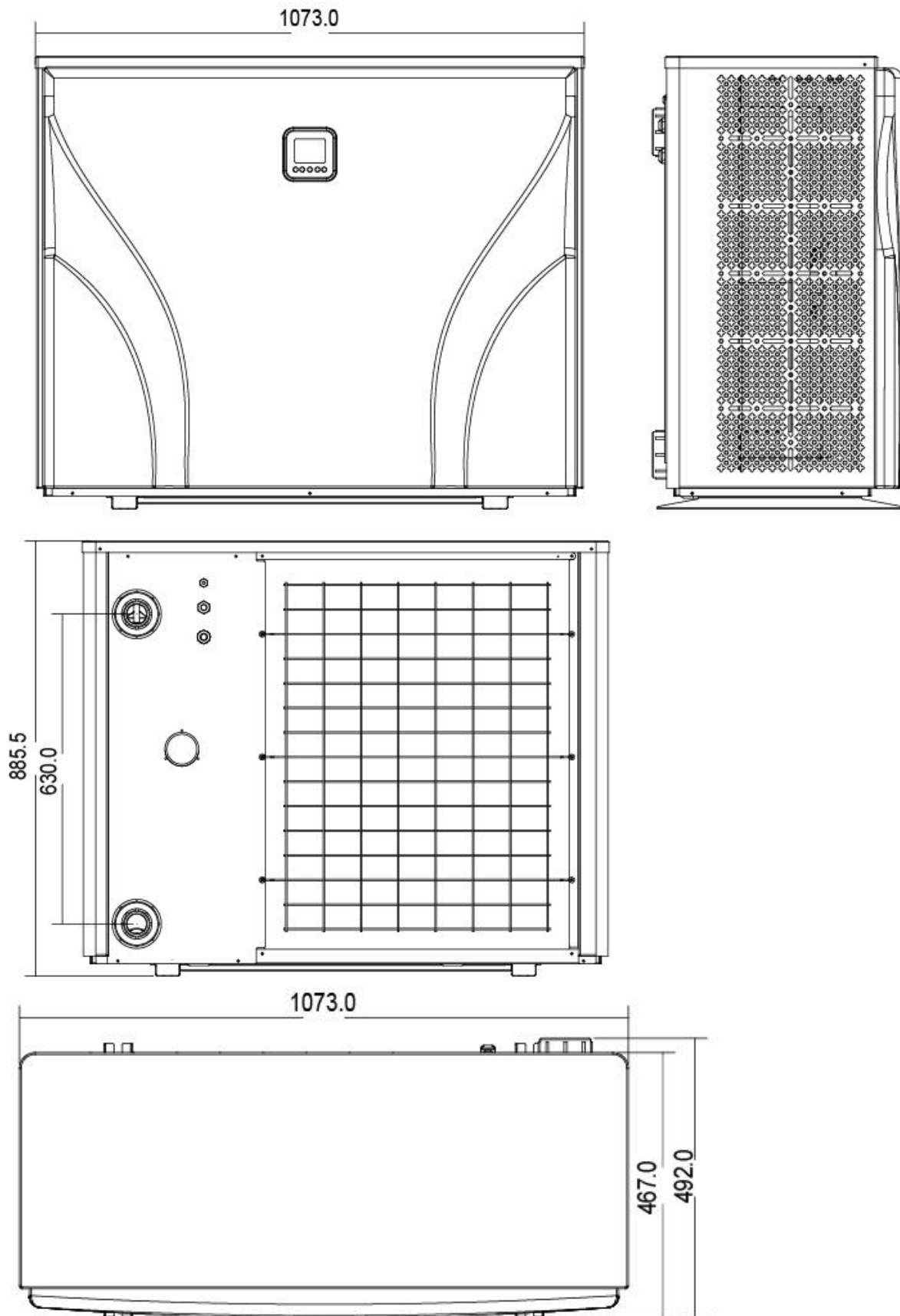

UX26Csi32

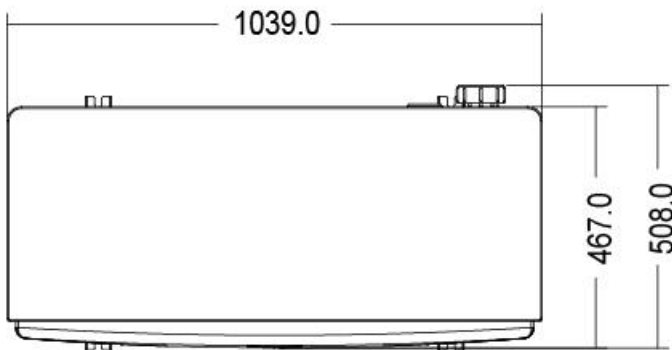
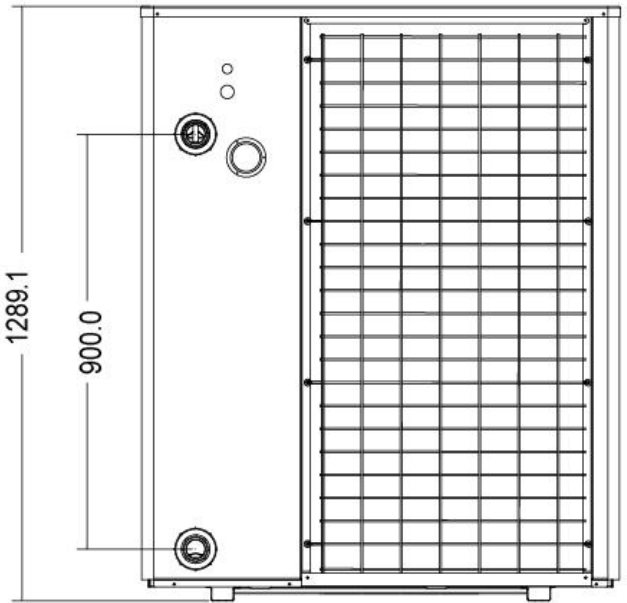
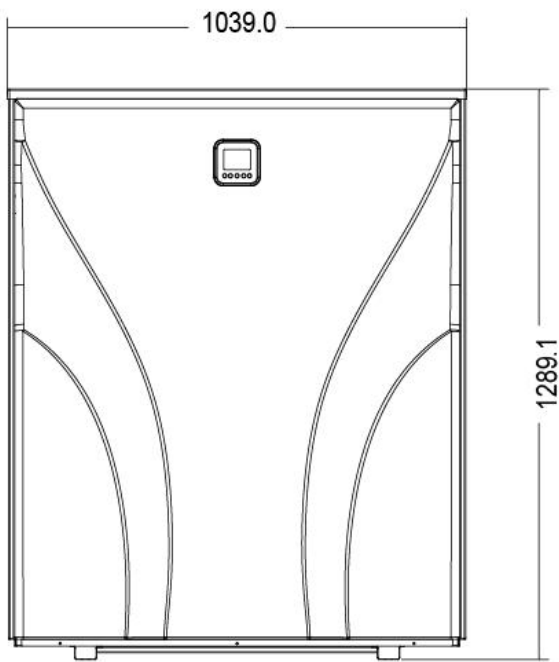

UX30Csi32/UX30Csi32T/UX35Csi32T

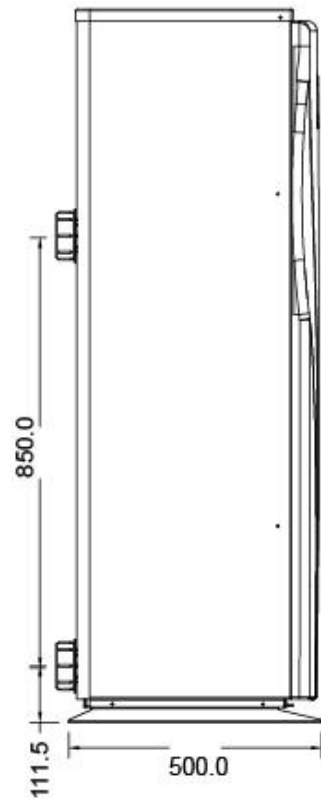
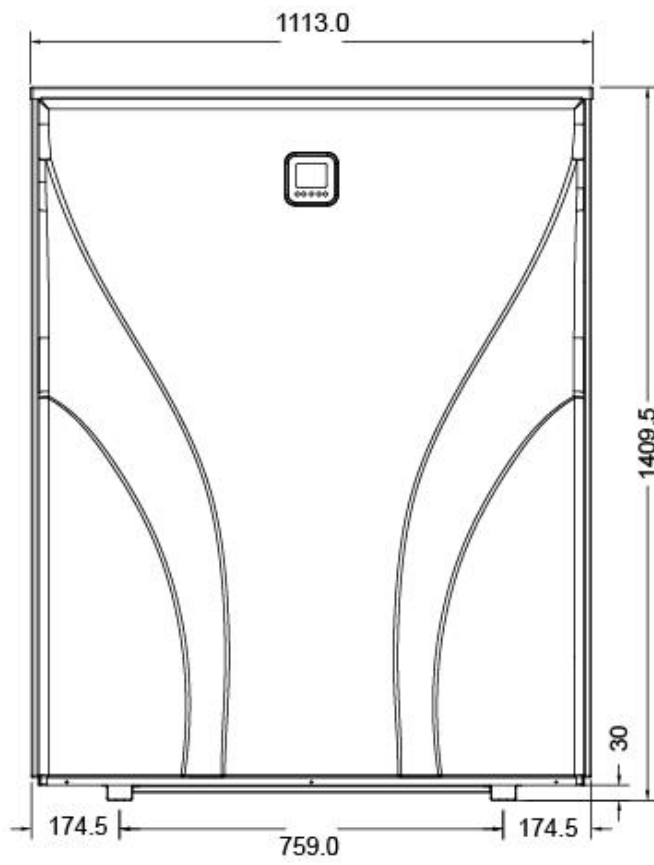

Unit: mm

### 3. Installation and connection

#### 3.1 Installation



##### Anti-vibration bases

1. Take out 4 Anti-vibration bases
2. Put them one by one on the bottom of machine like the picture.

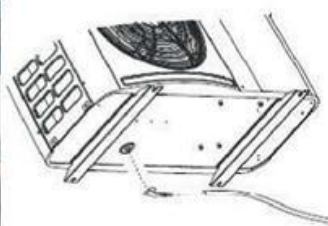

##### Draining jet

1. Install the draining jet under the bottom panel
2. Connect with a water pipe to drain out the water.

Note: Lift the heat pump to install the jet. Never overturn the heat pump, it could damage the compressor.



##### Water Inlet & outlet junction

1. Use the pipe tape to connect the water Inlet & outlet junction onto the heat pump
2. Install the two joints like the picture shows
3. Screw them onto the water Inlet & outlet junction



##### Mains Cable wiring

1. Open the cover of the electric box inside the machine
2. Connect the cables in the correct terminal according to electric diagram.

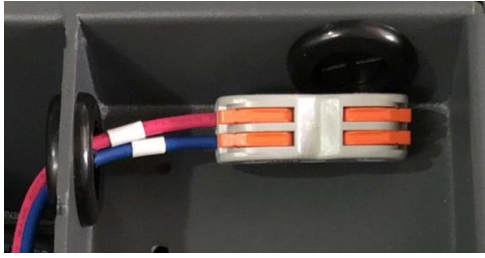

### Filtration pump wiring (Dry contact)

1. Open the cover of the electric box inside the machine
2. Connect the cables in the correct terminal according to electric diagram.

### Connection to pilot the water pump

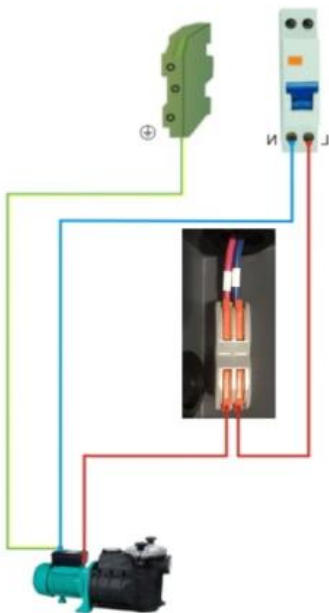
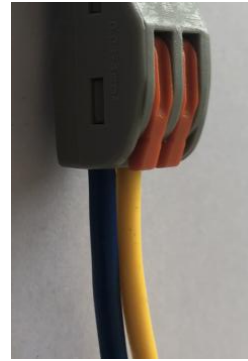
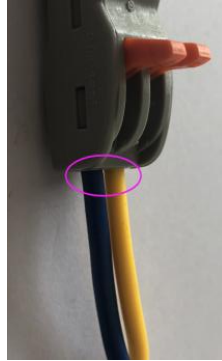
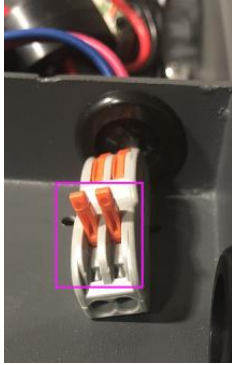

### Notes

The factory supplies only the heat pump. All other components, including a bypass if necessary, must be provided by the user or the installer.

### Attention:

Please observe the following rules when installing the heat pump:

1. Any addition of chemicals must take place in the piping located **downstream** from the heat pump.
2. Install a bypass if the water flow from the swimming pool pump is more than 20% greater than the allowable flow through the heat exchanger of the heat pump.
3. Install the heat pump above the water level of the swimming pool.
4. Always place the heat pump on a solid foundation and use the included rubber mounts to avoid vibration and noise.

5. Always hold the heat pump upright. If the unit has been held at an angle, wait at least 24 hours before starting the heat pump.

### 3.2 Heat pump location

The unit will work properly in any desired location as long as the following three items are present:

1. Fresh air
2. Electricity
3. Swimming pool filters

The unit may be installed in virtually any **outdoor** location as long as the specified minimum distances to other objects are maintained (see drawing below). Please consult your installer for installation with an indoor pool. Installation in a windy location does not present any problem at all, unlike the situation with a gas heater (including pilot flame problems).

**ATTENTION:** Never install the unit in a closed room with a limited air volume in which the air expelled from the unit will be reused, or close to shrubbery that could block the air inlet. Such locations impair the continuous supply of fresh air, resulting in reduced efficiency and possibly preventing sufficient heat output. See the drawing below for minimum dimensions.

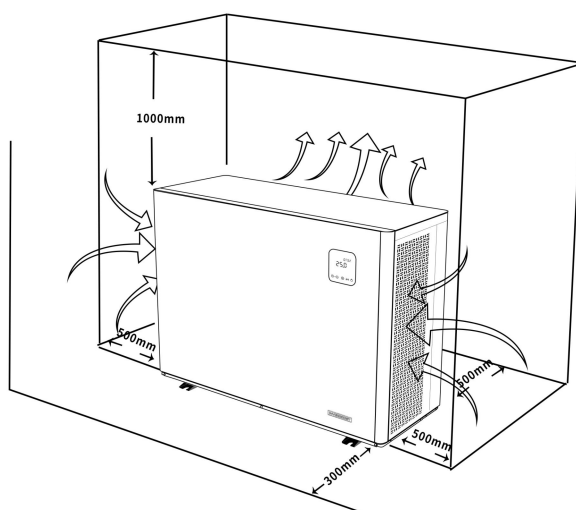

### 3.3 Distance from your swimming pool

The heat pump is normally installed within a perimeter area extending 7.5 m from the swimming pool. The greater the distance from the pool, the greater the heat loss in the pipes. As the pipes are mostly underground, the heat loss is low for distances up to 30 m (15 m from and to the pump; 30 m in total) unless the ground is wet or the groundwater level is high. A rough estimate of the heat loss per 30 m is 0.6 kWh (2,000 BTU) for every 5 °C difference between the water temperature in the pool and the temperature of the soil surrounding the pipe. This increases the operating time by 3% to 5%.

### 3.4 Check-valve installation

Note: If automatic dosing equipment for chlorine and acidity (pH) is used, it is essential to protect the heat pump against excessively high chemical concentrations which may corrode the heat exchanger. For this reason, equipment of this sort must always be fitted in the piping on the **downstream** side of the heat pump, and it is recommended to install a check-valve to prevent reverse flow in the absence of water circulation.

Damage to the heat pump caused by failure to observe this instruction is not covered by the warranty.

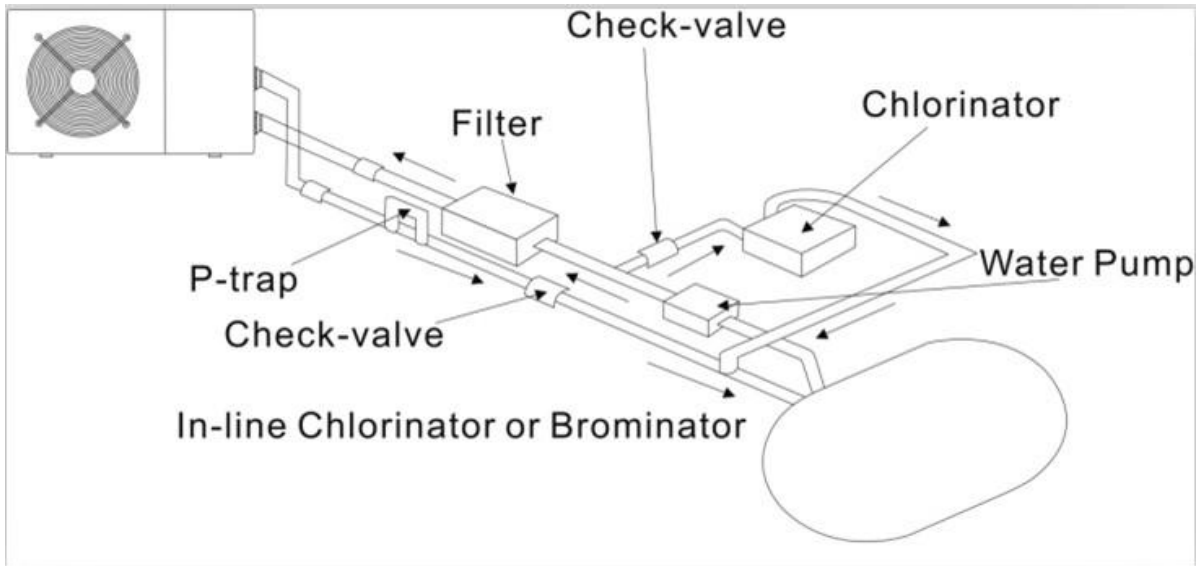

### 3.5 Typical arrangement

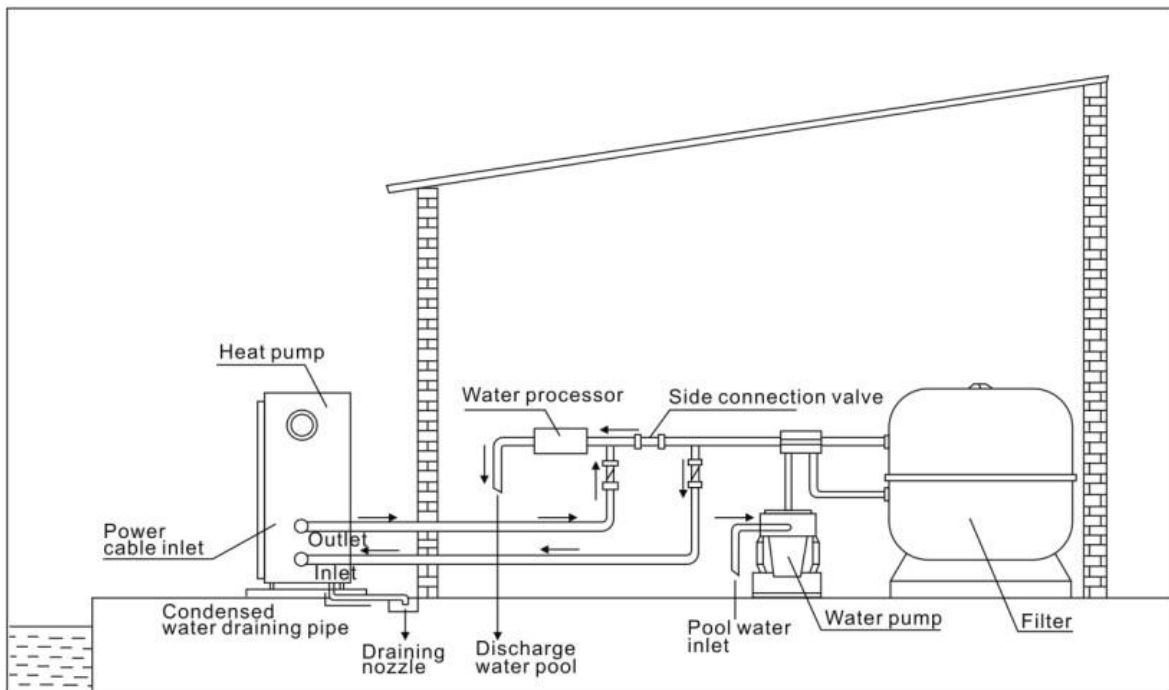

**Note: This arrangement is only an illustrative example.**

### 3.6 Initial operation

**Note: In order to heat the water in the pool (or hot tub), the filter pump must be running to cause the water to circulate through the heat pump. The heat pump will not start up if the water is not circulating.**

After all connections have been made and checked, carry out the following procedure:

1. Switch on the filter pump. Check for leaks and verify that water is flowing from and to the swimming pool.
2. Connect power to the heat pump and press the On/Off button  on the electronic control panel. The unit will start up after the time delay expires (see below).
3. After a few minutes, check whether the air blowing out of the unit is cooler.
4. When turn off the filter pump , the unit should also turn off automatically , if not, then adjust the flow switch.



5. Allow the heat pump and the filter pump to run 24 hours a day until the desired water temperature is reached. The heat pump will stop running at this point. After this, it will restart automatically (as long as the filter pump is running) whenever the swimming pool water temperature drops 2 degree below the set temperature.

Depending on the initial temperature of the water in the swimming pool and the air temperature, it may take several days to heat the water to the desired temperature. A good swimming pool cover can dramatically reduce the required length of time.

### **3.7 Condensation**

The air drawn into the heat pump is strongly cooled by the operation of the heat pump for heating the pool water, which may cause condensation on the fins of the evaporator. The amount of condensation may be as much as several liters per hour at high relative humidity. This is sometimes mistakenly regarded as a water leak.

## 4. Adjusting the bypass kit

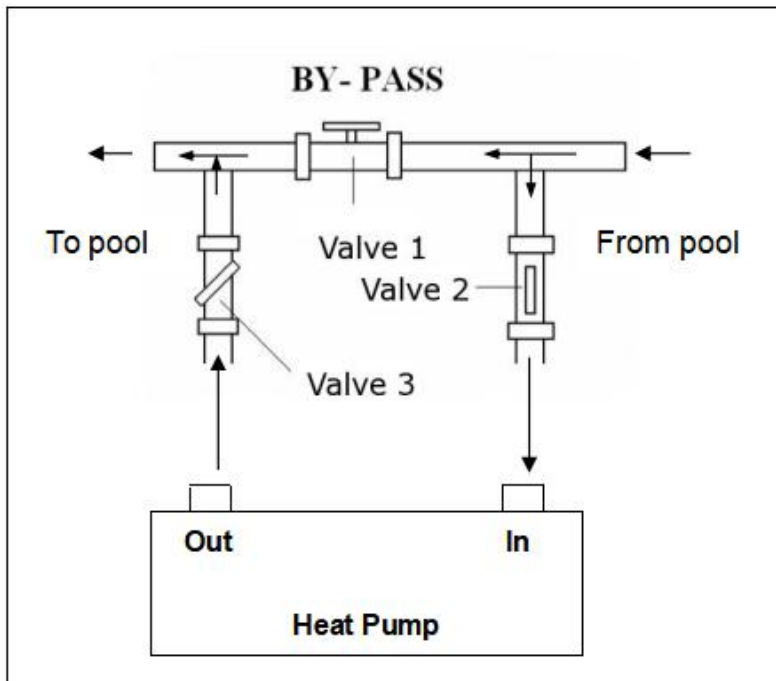

Use the following procedure to adjust the bypass:

- fully open all three valves
- slowly close valve 1 until the water pressure is increased by approximately 100 to 200 g
- Close valve 3 approximately half-way to adjust the gas pressure in the cooling system
- If the display shows "ON" or error code EE03, close step by step the valve 2, to increase water flow and stop when the code disappear.

Optimal operation of the heat pump occurs when the cooling gas pressure is  $22 \pm 2$  bar.

This pressure can be read on the pressure gauge next to the control heat pump panel. Under these conditions the water flow through the unit is also optimal.

**Note: Operation without a bypass or with improper bypass adjustment may result in sub-optimal heat pump operation and possibly damage to the heat pump, which renders the warranty null and void.**

### Water Flow Switch:

It is equipped with a flow switch for protecting the HP unit running with adequate water flow rate .It will turn on when the pool pump runs and shut it off when the pump shuts off. If the pool water level higher than 1 m above or below the heat pump's automatic adjustment knob, your dealer may need to adjust its initial start-up.

**Time delay** - The heat pump has a built-in 3-minute start-up delay to protect the circuitry and avoid excessive contact wear. The unit will restart automatically after this time delay expires. Even a brief power interruption will trigger this time delay and prevent the unit from restarting immediately. Additional power interruptions during this delay period do not affect the 3-minute duration of the delay.

# 5. Display Controller Operation

## 5.1. Guide for operation





When the heat pump connects to the power, the display shows a code for 3 seconds which indicates the heat pump model.

## 5.2 The keys and their operations

### 5.2.1 button

Press  to start the heat pump unit, the display shows the desired water temperature for 5 seconds, then shows the inlet water temperature and the operation mode.



Press  to stop the heat pump unit and show "OFF"

Notice : During the parameter checking and setting, press the  to quick-exit and save the current setting .

Press  again to turn on/off the machine.



### 5.2.2 and button

**Lock/unlock the display:**

Hold  and  for 5 seconds to lock/Unlock the display.

The display will lock automatically after 30s of standby. (when the display is locked, the "locker  " icon is lighted ON)

**Water temperature setting:**

Press  or  to set the water temperature directly.

Heating mode and Auto mode setting range: 6-41 °C

Cooling mode setting range: 6-35 °C

### 5.2.3 button working mode

Press  to change the working mode, Turbo, Smart and Silent. The default mode is smart mode. While you choose the **Turbo**, the word "Turbo" will be lit, the heat pump will operate in 'Full output' only. Choose the **Smart**, the word "Smart" will be lit, the heat pump will operate in 'Medium and Full output'. Choose the **Silent**, the word "Silent" will be lit, heat pump will operate in 'Medium and Small output'.

### 5.2.4 button mode



Press  for 5S to switch the heating mode , cooling mode  and auto mode .

Remark: When defrosting, the heating symbol will flash.

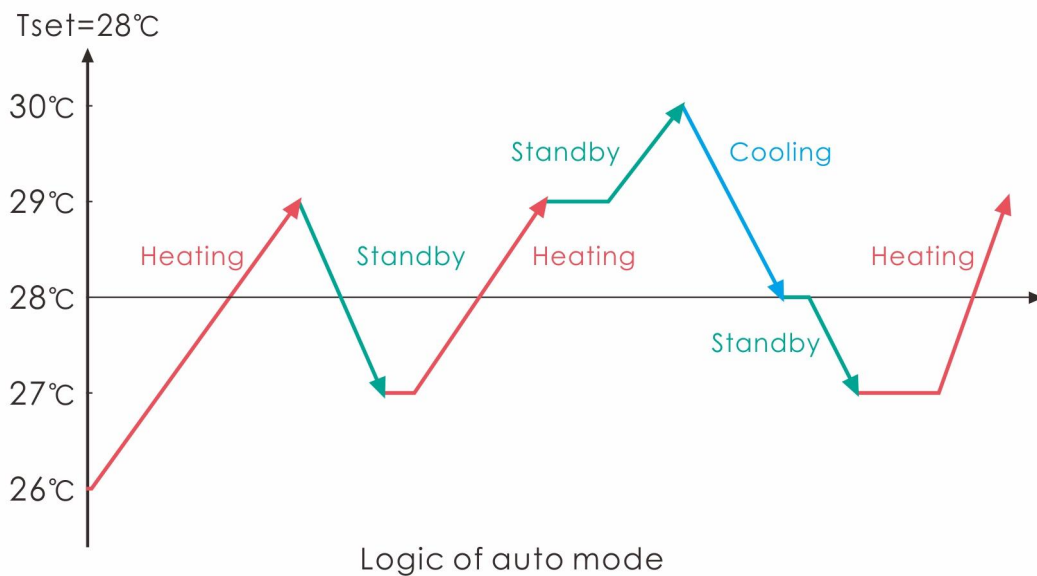
#### Operation logic of Auto Mode:



### 5.2.5 Parameter checking

Press , then press  to check d0-d14 value. 

Code	Condition	Scope	Remark
d0	IPM mould temperature	0-120℃	Real testing value
d1	Inlet water temp.	-9℃～99℃	Real testing value
d2	Outlet water temp.	-9℃～99℃	Real testing value
d3	Ambient temp.	-30℃～70℃	flash if Real value<-9
d4	Frequency limitation code	0,1,2,4,8,16	Real testing value
d5	Piping temp.	-30℃～70℃	flash if Real value<-9
d6	Gas exhaust temprature	0℃～C5℃ (125℃)	Real testing value
d7	Step of EEV	0～99	N*5
d8	Compressor running frequency	0～99Hz	Real testing value
d9	Compressor current	0～30A	Real testing value
d10	Current fan speed	0-1200 (rpm)	Real testing value
d11	Error code for last time	All error code	

Remark:

d4: Frequency limitation code,

0: No frequency limit;



1:Coil pipe temperature limit;

2: Overheating or overcooling frequency limit; 4:Drive Current frequency limit;

8:Drive voltage frequency limit;

16:Drive high temperature frequency limit

## 5.2.6 Parameter setting

Press , then press  to choose P0-P18 value, and press  again to enter the setting interface, in which parameter will flash.

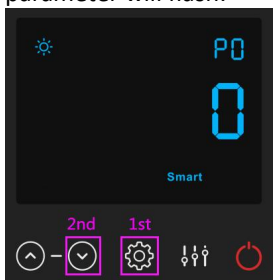







Code	Name	Scope	Default	Remark
P0	Mandatory defrosting	0-1	0	0: Default normal operation 1: mandatory defrosting.
P1	Working mode	0-1	1	1:Heating mode, 0:cooling mode,
P2	Timer on/off	0-1	0	1 Timer on/off is under function, 0 Timer on/off is out of function (The setting of P5 and P6 won't work)
P3	Water pump	0-1	0	1:Always running; 0:Depends on the running of compressor
P4	Current time	HH:MM	00: 00	<u>0-23:0-59</u>
P5	Timer on	HH:MM	00: 00	<u>0-23:0-59</u>
P6	Timer off	HH:MM	00: 00	<u>0-23:0-59</u>
P7	Water temp. calibration	-9~9	0	Default setting: 0
P14	Restore to factory settings	0-1	0	1-Restore to factory settings, 0- default (restore P0, P1, P2, P3, P5, P6, P7, P8, P9, 10, P11 to factory setting)
P16	Product code	/	/	Depends on the machine
P18	Mode	0-1	0	1—Heating only, 0—Heating/Cooling/Auto mode

Note:

- 1). Long press  for 20s to set P14, P16, P18.
- 2). P8,P9,P10,P11,P19,P20 parameter is only for factory setting.

### 5.2.7 System reset function

Press  , then press  to choose P14, and enter into the value setting interface by long press  for 20s, in which parameter will flash. Press  or  to set the value 1, finally press  to save settings.

### 5.2.8

Symbol of TIMER ON, the light will be on when the value of P2 is 1, which means TIME ON & OFF function is working. Then set the current time(Parameter P4), TIMER ON (Parameter P5) and TIMER OFF (Parameter P6). All the symbols (except symbol ) on the display will be off when TIMER is OFF.

Note: The symbol  keeps on when restart the heat pump after TIME OFF, unless the value of P2 is set to 0.

### 5.2.9 System filtration pilot function

#### Option 1; P3=0 Filtration pump is related to heat pump operation to start and stop.

Filtration pump starts 60s before compressor, filtration pump start 30s and then the water flow switch detect flow. Before the heat pump enters into Standby mode, the compressor stops first and after 5 minutes filtration pump stops.

	Condition	Example	Water pump working logic	
Heating mode	P3=0, T1≥Tset-0.5°C, last for 30 minutes	P3=0, T1≥27.5°C, last for 30 minutes	1. Then it enters into standby mode for 1 hour (It will not restart except turn it on manually.)	2. After 1 hour, the filtration pump will restart for 5 minutes. If the T1≤27°C, the heat pump will start to work until T1≥27.5°C and last for 30 minutes to go into standby
Cooling mode	P3=0, T1≤Tset+0.5°C, last for 30 minutes	P3=0, T1≤28.5°C, last for 30 minutes	1. Then it enters into standby mode for 1 hour (It will not restart except turn it on manually.)	2. After 1 hour, the filtration pump will restart for 5 minutes. If it tests T1≥29°C, the heat pump will start to work until T1≤28.5°C and last for 30 minutes to go into standby

#### Option 2; P3=1 Filtration pump is always on, P2=0 the timer function is no active

Under condition P3=1, when T1≥Tset+1°C (T1≥29°C) last for 3 minutes, heat pump will be in standby, while filtration pump is always on.

**Under option 2, with activation of the timer; P2=1 to start and stop the filtration pump according the programming of the P4 (time), P5 (timer ON) and P6 (timer OFF)**

#### Condition for the heat pump start, timer ON actives;

When the timer reaches **the set time of TIMER ON**, the filtration pump will start and after 5 minutes the heat pump start. The heat pump stays in stop if the water in temperature is ≥ Tset+1°C, before the TIMER OFF, the filtration is still activated.

#### Condition to stop the heat pump, timer OFF actives;

When the timer reaches the set time of the TIMER OFF, the heat pump will stop and after 5 minutes the filtration pump stops.

**If heat pump is turned ON/OFF manually, the filtration pump will start and stop accordingly.**

#### NOTE :

Tset = Tseting water temperature

For example : Tset = 28°C Tseting water temperature in your pool heat pump

Tset-0.5 = less 0.5°C than Tseting temperature, Tset- 0.5 = 28-0.5=27.5°C

Tset+0.5= more 1°C than Tseting temperature, Tset+ 0.5 = 28+0.5=28.5°C

### 5.3 Heating operation logic

Working status		Working mode	Water in temperature-T1	For example, water in temperature-T1	Heat pump working level
1	Start-up of heat pump	When you select the "Smart working mode "	$T1 < Tset-1$	$T1 < 27^{\circ}C$	Powerful mode-frequency F9
2			$Tset-1 \leq T1 < Tset$	$27^{\circ}C \leq T1 < 28^{\circ}C$	Frequency: F9 -F8-F7,...,-F2
3			$Tset \leq T1 < Tset+ 1$	$28^{\circ}C \leq T1 < 29^{\circ}C$	Silent mode-frequency F2
4			$T1 \geq Tset+1$	$T1 \geq 29^{\circ}C$	HP will be in Standby, stop working until the water temperature drops to less $28^{\circ}C$ .
5		When you select the "Silent working mode".	$T1 < Tset$	$T1 < 28^{\circ}C$	Smart mode -frequency F5.
6			$Tset \leq T1 < Tset+1$	$28^{\circ}C \leq T1 < 29^{\circ}C$	Silent mode-frequency F2/F1.
7			$T1 \geq Tset+1$	$T1 \geq 29^{\circ}C$	HP will be in Standby, stop working until the water temperature drops to less $28^{\circ}C$ .
8		When you select the "Powerful working mode."	$T1 < Tset+1$	$T1 < 29^{\circ}C$	Powerful mode-frequency F10/F9
9			$T1 \geq Tset+1$	$T1 \geq 29^{\circ}C$	HP will be in Standby, stop working until the water temperature drops to less $28^{\circ}C$ .
10	Re-start to heat water in standby status	When HP is working at " Smart mode"	$T1 \geq Tset$	$T1 \geq 28^{\circ}C$	Standby
11			$Tset > T1 \geq Tset-1$	$28^{\circ}C > T1 \geq 27^{\circ}C$	Silent-frequency F2
12			$Tset-1 > T1 \geq Tset-2$	$27^{\circ}C > T1 \geq 26^{\circ}C$	Frequency: F2 -F3-F4,...,-F9
13			$< Tset-2$	$< 26^{\circ}C$	Powerful-frequency F9
14		When HP is working at " Silent mode"	$\geq Tset$	$\geq 28^{\circ}C$	Standby
15			$Tset > T1 \geq Tset-1$	$28^{\circ}C > T1 \geq 27^{\circ}C$	Silent mode-frequency F2/F1
16			$T1 < Tset-1$	$T1 < 27^{\circ}C$	Smart -frequency F5
17	When HP is working at " Powerful mode"	$T1 < Tset-1$	$T1 < 27^{\circ}C$	Powerful -frequency F10/F9	



## 5.4 Cooling operation logic

Working status	Working mode	Water in temperature	For example, water in temperature	Heat pump working level
1	When you select the "Smart working mode "	$T1 \leq T_{set}-1$	$T1 \leq 27^{\circ}\text{C}$	Standby.
2		$T_{set}-1 < T1 \leq T_{set}$	$27^{\circ}\text{C} < T1 \leq 28^{\circ}\text{C}$	Silent mode-frequency F2
3		$T_{set} < T1 \leq T_{set}+1$	$28 < T1 \leq 29^{\circ}\text{C}$	frequency: F9 -F8-F7,...,- F2
4		$T1 \geq T_{set}+1$	$T1 \geq 29^{\circ}\text{C}$	Powerful mode-F9
5	Start-up of heat pump When you select the "Silent working mode".	$T1 \leq T_{set}-1$	$\leq 27^{\circ}\text{C}$	Standby
6		$T_{set}-1 < T1 \leq T_{set}$	$27^{\circ}\text{C} < T1 \leq 28^{\circ}\text{C}$	Silent mode - frequency F2/F1
7		$T1 > T_{set}$	$T1 > 28^{\circ}\text{C}$	Smart mode -frequency F5
8	When you select the "Powerful working mode."	$T1 > T_{set}-1$	$T1 > 27^{\circ}\text{C}$	Powerful mode-frequency F10/F9
9		$T1 \leq T_{set}-1$	$T1 \leq 27^{\circ}\text{C}$	Standby
10	Re-start to cool water in standby status Smart	$T1 \leq T_{set}-1$	$T1 \leq 27^{\circ}\text{C}$	Standby
11		$T_{set} \leq T1 < T_{set}+1$	$28 \leq T1 < 29^{\circ}\text{C}$	Silent- frequency F2
12		$T_{set}+1 \leq T1 < T_{set}+2$	$29 \leq T1 < 30^{\circ}\text{C}$	Frequency: F2 -F3-F4,...,- F9
13		$T1 \geq T_{set}+2$	$T1 \geq 30^{\circ}\text{C}$	Powerful mode -frequency F9
14	Silent	$T_{set} < T1 \leq T_{set}+1$	$28 < T1 \leq 29^{\circ}\text{C}$	Silent mode-frequency F2/F1
15		$T1 > T_{set}+1$	$T1 > 29^{\circ}\text{C}$	Smart mode-frequency F5
16	Powerful	$T1 > T_{set}+1$	$T1 > 29^{\circ}\text{C}$	Powerful mode-frequency F10/F9
17		$T1 \leq T_{set}-1$	$T1 \leq 27^{\circ}\text{C}$	Standby

## 6. Malfunction and Trouble Shooting

### 6.1 Error code display on LED wire controller

Malfunction	Error code	Reason	Solution
Inlet water temperature sensor failure	PP01	1. The sensor in open or short circuit 2. The wiring of sensor is loose	1. Check or change the sensor 2.Re-fix the wiring of the sensors
Outlet water temperature sensor failure	PP02	1. The sensor in open or short circuit 2. The wiring of sensor is loose	1. Check or change the sensor 2.Re-fix the wiring of the sensors
Heating piping sensor failure	PP03	1. The sensor in open or short circuit 2. The wiring of sensor is loose	1. Check or change the sensor 2.Re-fix the wiring of the sensors
Gas return sensor failure	PP04	1. The sensor in open or short circuit 2. The wiring of sensor is loose	1. Check or change the sensor 2.Re-fix the wiring of the sensors
Ambient temperature sensor failure	PP05	1. The sensor in open or short circuit 2. The wiring of sensor is loose	1. Check or change the sensor 2.Re-fix the wiring of the sensors
Exhaust piping sensor failure	PP06	1. The sensor in open or short circuit 2. The wiring of sensor is loose	1. Check or change the sensor 2.Re-fix the wiring of the sensors
Antifreeze protection in Winter	PP07	Ambient temperature or water inlet temperature is too low	Normal protection
Low ambient temperature protection	PP08	1.Beyond the scope of using environment 2. Sensor abnormality	1. Stop using, beyond the scope of using 2.Change the sensor
Piping temperature too high protection under cooling mode	PP10	1. Ambient temperature is too high or the water temperature is too high in cooling mode 2. Refrigeration system is abnormal	1. Check the scope of using 2. Check refrigeration system
T2 water temp. Too low protection under cooling mode	PP11	1. Low water flow 2. T2 temperature sensor abnormal	1. Check water pump and waterway system 2. Change T2 temperature sensor
High pressure failure	EE01	1. Ambient temperature is too high 2. Water temperature is too high 3. Water flow is too low Fan motor speed is abnormal or fan motor has damaged	1. Check the water flow or water pump 2. Check the fan motor 3. Check and repair the piping system
Low pressure failure	EE02	1. EEV has blocked or pipe system is jammed 2. Motor speed is abnormal or motor has damaged 3. Gas leakage	1. Check the EEV and piping system Check the motor 2. Through the high pressure gauge to check the pressure value
Water flow failure	ON	1. Water flow switch is damaged 2. No/ Insufficient water flow.	1. Change the water flow switch 2. Check the water pump or the waterway system
Over heating protection for water temperature (T2) in heating mode	EE04	1. Low water flow 2. Water flow switch is stuck and the water supply is cut off 3. T2 sensor is abnormal	1. Check the water way system 2. Check the water pump or water flow switch 3. CheckT2 sensor or change another one
T6 Exhaust too high protection	EE05	1.Lack of gas 2.Low water flow 3.Piping system has been blocked 4.Exhaust temp. Sensor failure	1. Check the high pressure gauge, if too low, fill with some gas 2. Check the waterway system and water pump 3. Check the piping system if there was any block 4. Change a new exhaust temp. sensor
Controller failure	EE06	1. Wire connection is not good, or damaged signal wire 2. Controller failure	1. Check and re-connect the signal wire 2. Change a new signal wire 3. Turn off electricity supply and

			restart machine 4. Change anew controller
Compressor current protection	EE07	<ol style="list-style-type: none"> <li>1. The compressor current is too large instantaneously</li> <li>2. Wrong connection for compressor phase sequence</li> <li>3. Compressor accumulations of liquid and oil lead to the current becomes larger</li> <li>4. Compressor or driver board damaged</li> <li>5. The water flow is abnormal</li> <li>6. Power fluctuations within a short time</li> </ol>	<ol style="list-style-type: none"> <li>1. Check the compressor</li> <li>2. Check the waterway system</li> <li>3. Check if the power in the normal range</li> <li>4. Check the phase sequence connection</li> </ol>
Communication failure between controller and main board	EE08	<ol style="list-style-type: none"> <li>1. Poor signal wire connection or damaged signal wire</li> <li>2. Controller malfunction</li> </ol>	<ol style="list-style-type: none"> <li>1. Check and re-connect the signal wire</li> <li>2. Change a new signal wire</li> <li>3. Turn off electricity supply and restart machine</li> <li>4. Change anew controller</li> </ol>
Communication failure between Main control board and Driving board	EE09	<ol style="list-style-type: none"> <li>1. Poor connection of communication wire</li> <li>2. The wire is damaged</li> </ol>	<ol style="list-style-type: none"> <li>1. Check the wire connection</li> <li>2. Change a new wire</li> </ol>
VDC voltage too high protection	EE10	<ol style="list-style-type: none"> <li>1. Mother line voltage is too high</li> <li>2. Driver board is damaged.</li> </ol>	<ol style="list-style-type: none"> <li>1. Check if the power is in the normal range</li> <li>2. Change driver board or main board</li> </ol>
IPM module protection	EE11	<ol style="list-style-type: none"> <li>1. Data mistake</li> <li>2. Wrong compressor phase connection</li> <li>3. Compressor liquid and oil accumulation lead to the current becomes larger</li> <li>4. Compressor or driver board damaged</li> </ol>	<ol style="list-style-type: none"> <li>1. Program error, turn off electricity supply and restart after 3 minutes</li> <li>2. Change driver board</li> <li>3. Check compressor sequence connection</li> </ol>
VDC voltage too low protection	EE12	<ol style="list-style-type: none"> <li>1. Mother line voltage is too low</li> <li>2. Driver board is damaged.</li> </ol>	<ol style="list-style-type: none"> <li>1. Check if the power is in the normal range</li> <li>2. Change driver board</li> </ol>
Input current over high protection.	EE13	<ol style="list-style-type: none"> <li>1. The compressor current is too large momentary</li> <li>2. The water flow is abnormal</li> <li>3. Power fluctuations within a short time</li> <li>4. Wrong PFC inductor</li> </ol>	<ol style="list-style-type: none"> <li>1. Check the compressor</li> <li>2. Check the waterway system</li> <li>3. Check if the power is in the normal range</li> <li>4. Check if the correct PFC inductor is used</li> </ol>
IPM module thermal circuit is abnormal	EE14	<ol style="list-style-type: none"> <li>1. Output enormity of IPM module thermal circuit</li> <li>2. Fan motor is abnormal or damaged</li> <li>Fan blade is broken</li> </ol>	<ol style="list-style-type: none"> <li>1. Change a driver board</li> <li>2. Check if the motor speed is too low or fan motor damaged, change another one</li> <li>3. Change another fan blade</li> </ol>
IPM module temperature too high protection	EE15	<ol style="list-style-type: none"> <li>1. Output exception of IPM module thermal circuit</li> <li>2. Motor is abnormal or damaged</li> <li>3. Fan blade is broken</li> </ol>	<ol style="list-style-type: none"> <li>1. Change a driver board</li> <li>2. Check if the fan motor speed is too low or fan motor damaged, change another one</li> <li>3. Change another fan blade</li> </ol>
PFC module protection	EE16	<ol style="list-style-type: none"> <li>1. Output exception of PFC module</li> <li>2. Motor is abnormal or damaged</li> <li>3. Fan blade is broken</li> <li>4. Input voltage leap, input power is abnormal</li> </ol>	<ol style="list-style-type: none"> <li>1. Change a driver board</li> <li>2. Check if the motor speed is too low or fan motor damaged, change another one</li> <li>3. Change another fan blade</li> <li>4. Check the input voltage</li> </ol>
DC fan motor failure	EE17	<ol style="list-style-type: none"> <li>1. DC motor is damaged</li> <li>2. Main board is damaged</li> <li>3. The fan blade is stuck</li> </ol>	<ol style="list-style-type: none"> <li>1. Detect DC motor, replace with a new one</li> <li>2. Change a new main board</li> <li>3. Find out the barrier and work it out</li> </ol>

PFC module thermal circuit is abnormal	EE18	The driver board is damaged	<ol style="list-style-type: none"> <li>1. Change a new driver board</li> <li>2. Check if the fan motor speed is too low or fan motor damaged, change another one</li> </ol>
PFC module high temperature protection	EE19	<ol style="list-style-type: none"> <li>1. PFC module thermal circuit output abnormal</li> <li>2. Motor is abnormal or damaged</li> <li>3. Fan blade is broken</li> <li>4. The screw in the driver board is not tight</li> </ol>	<ol style="list-style-type: none"> <li>1. Change a new driver board</li> <li>2. Check if the motor speed is too low or fan motor damaged, change another one</li> <li>3. Change another fan blade</li> <li>4. Check if the screw is loose</li> </ol>
Input power failure	EE20	The supply voltage fluctuates too much	Check whether the voltage is stable
Software control exception	EE21	<ol style="list-style-type: none"> <li>1. Compressor runs out of step</li> <li>2. Wrong program</li> <li>3. Impurity inside compressor causes the unstable rotate speed</li> </ol>	<ol style="list-style-type: none"> <li>1. Check the main board or change a new one</li> <li>2. Enter correct program</li> </ol>
Current detection circuit failure	EE22	<ol style="list-style-type: none"> <li>1. Voltage signal abnormal</li> <li>2. Driver board is damaged</li> </ol>	<ol style="list-style-type: none"> <li>1. Check the main board or change a new one</li> <li>2. Change a new driver board</li> </ol>
Compressor start failure	EE23	<ol style="list-style-type: none"> <li>1. Main board is damaged</li> <li>2. Compressor wiring error or poor contact or unconnected</li> <li>3. Liquid accumulation inside</li> <li>4. Wrong phase connection for compressor</li> </ol>	<ol style="list-style-type: none"> <li>1. Check the main board or change a new one</li> <li>2. Check the compressor wiring according to the circuit diagram</li> </ol> <p>Check the compressor or change a new one</p>
Ambient Temperature device failure on Driver board	EE24	Ambient Temperature device failure	Change driver board or main board
Compressor phase failure	EE25	Compressors U, V, W are connected to one phase or two phases.	Check the actual wiring according to the circuit diagram
Four-way valve reversal failure	EE26	<ol style="list-style-type: none"> <li>1. Four-way valve reversal failure</li> <li>2. Lack of refrigerant (no detect when T3 or T5 malfunction)</li> </ol>	<ol style="list-style-type: none"> <li>1. Switch to Cooling mode to check the 4-way valve if it has been reversed correctly</li> <li>2. Change a new 4-way valve</li> <li>3. Fill with gas</li> </ol>
EEPROM data read malfunction	EE27	<ol style="list-style-type: none"> <li>1. Wrong EEPROM data in the program or failed input of EEPROM data</li> <li>2. Main board failure</li> </ol>	<ol style="list-style-type: none"> <li>1. Re-enter correct EEPROM data</li> <li>2. Change a new main board</li> </ol>
The inter-chip communication failure on the main control board	EE28	Main board failure	<ol style="list-style-type: none"> <li>1. Turn off electricity supply and restart it</li> <li>2. Change a new main board</li> </ol>

**Remarks:**

1. In heating mode, if the water out temperature is higher than the set temperature over 7°C, LED controller displays EE04 for water over-heating protection.
2. In cooling mode, if the water out temperature is lower than the set temperature over 7°C, LED controller displays PP11 for water over-cooling protection.

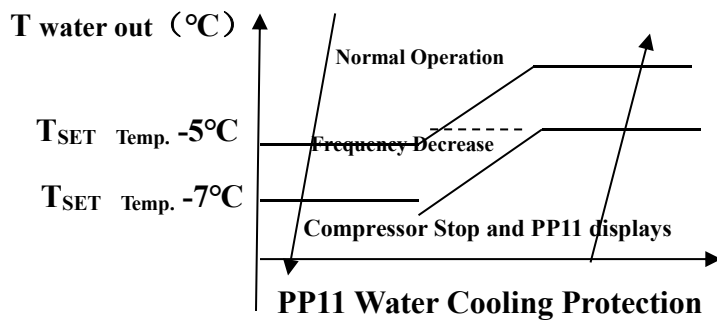
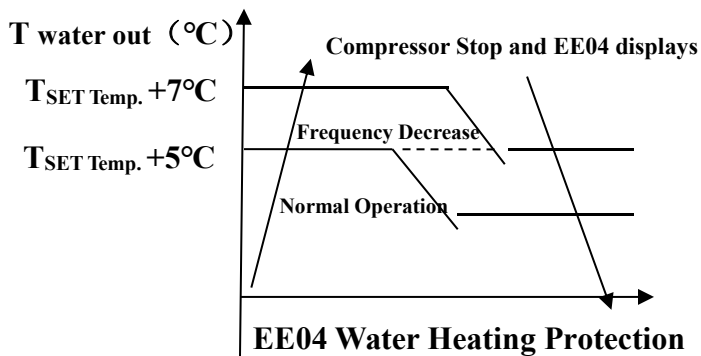

For example below:

Mode	Water out temperature	Setting temperature	Condition	Malfunction
Heating mode	36°C	29°C	$T_{out} - T_{set} \cong 7^{\circ}\text{C}$	EE04 Over heating protection for water temperature (T2)
Cooling mode	23°C	30°C	$T_{set} - T_{out} \cong 7^{\circ}\text{C}$	PP11 Too low protection for water temperature (T2)

## 6.2 Other Malfunctions and Solutions (No display on LED wire controller)

Malfunctions	Observing	Reasons	Solution
Heat pump is not running	LED wire controller no display.	No power supply	Check cable and circuit breaker if it is connected
	LED wire controller displays the actual time.	Heat pump under standby status	Startup heat pump to run.
	LED wire controller displays the actual water temperature.	<ol style="list-style-type: none"> <li>1. Water temperature is reaching to setting value, HP under constant temperature status.</li> <li>2. Heat pump just starts to run.</li> <li>3. Under defrosting.</li> </ol>	<ol style="list-style-type: none"> <li>1. Verify water temperature setting.</li> <li>2. Startup heat pump after a few minutes.</li> <li>3. LED wire controller should display "Defrosting".</li> </ol>
Water temperature is cooling when HP runs under heating mode	LED wire controller displays actual water temperature and no error code displays.	<ol style="list-style-type: none"> <li>1. Choose the wrong mode.</li> <li>2. Figures show defects.</li> <li>3. Controller defect.</li> </ol>	<ol style="list-style-type: none"> <li>1. Adjust the mode to proper running</li> <li>2. Replace the defect LED wire controller, and then check the status after changing the running mode, verifying the water inlet and outlet temperature.</li> <li>3. Replace or repair the heat pump unit</li> </ol>
Short running	LED displays actual water temperature, no error code displays.	<ol style="list-style-type: none"> <li>1. Fan NO running.</li> <li>2. Air ventilation is not enough.</li> <li>3. Refrigerant is not enough.</li> </ol>	<ol style="list-style-type: none"> <li>1. Check the cable connections between the motor and fan, if necessary, it should be replaced.</li> <li>2. Check the location of heat pump unit, and eliminate all obstacles to make good air ventilation.</li> <li>3 Replace or repair the heat pump unit.</li> </ol>
Water stains	Water stains on heat pump unit.	<ol style="list-style-type: none"> <li>1. Concreting.</li> <li>2. Water leakage.</li> </ol>	<ol style="list-style-type: none"> <li>1. No action.</li> <li>2. Check the titanium heat exchanger carefully if it is any defect.</li> </ol>
Too much ice on evaporator	Too much ice on evaporator.		<ol style="list-style-type: none"> <li>1. Check the location of heat pump unit, and eliminate all obstacles to make good air ventilation.</li> <li>2. Replace or repair the heat pump unit.</li> </ol>

# 7. Electrical Wiring

UX11Csi32/UX14Csi32/UX17Csi32/UX21Csi32

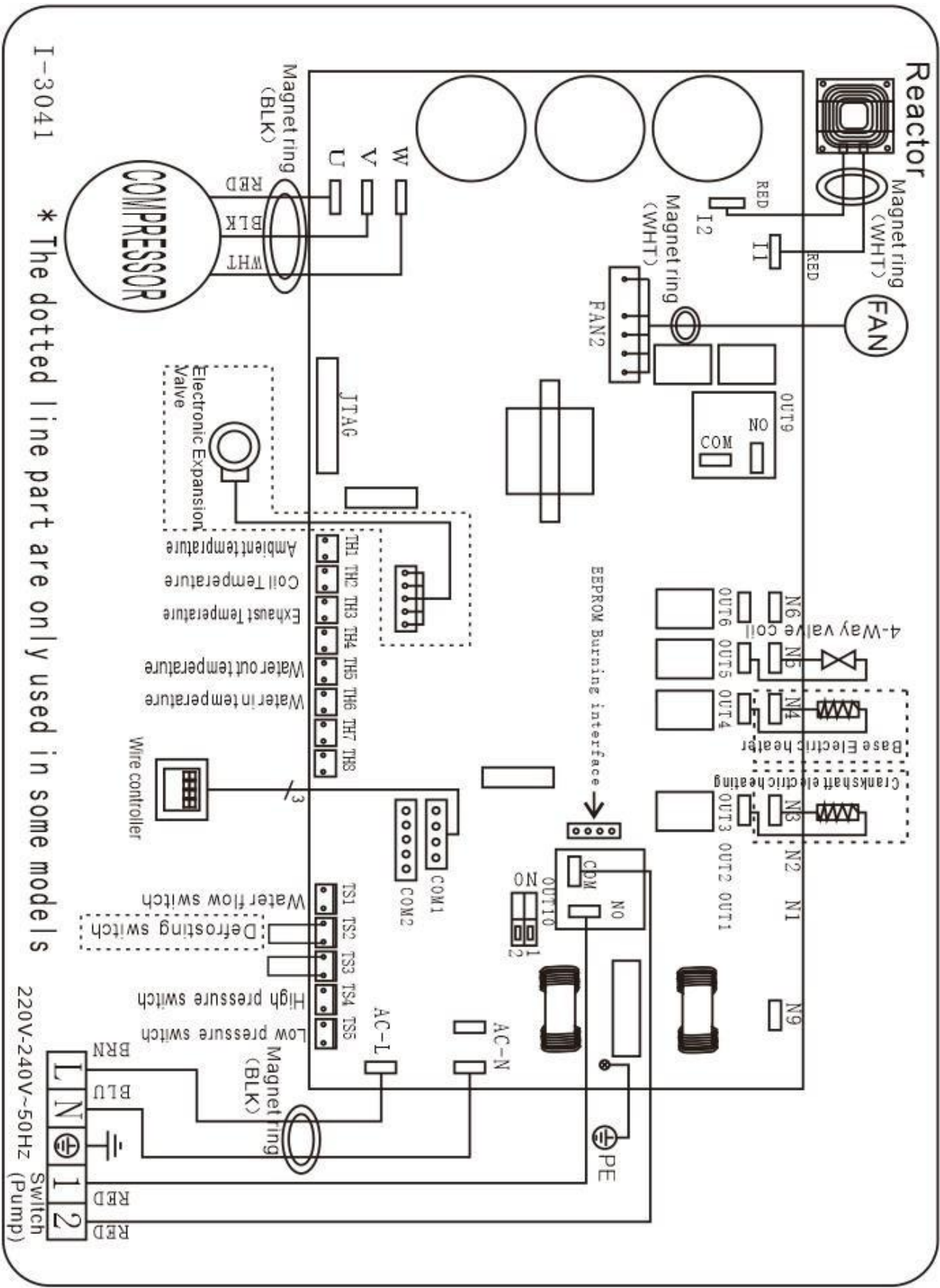

I-3041

\* The dotted line part are only used in some models

I-3051S \* The dotted line part are only used in some models

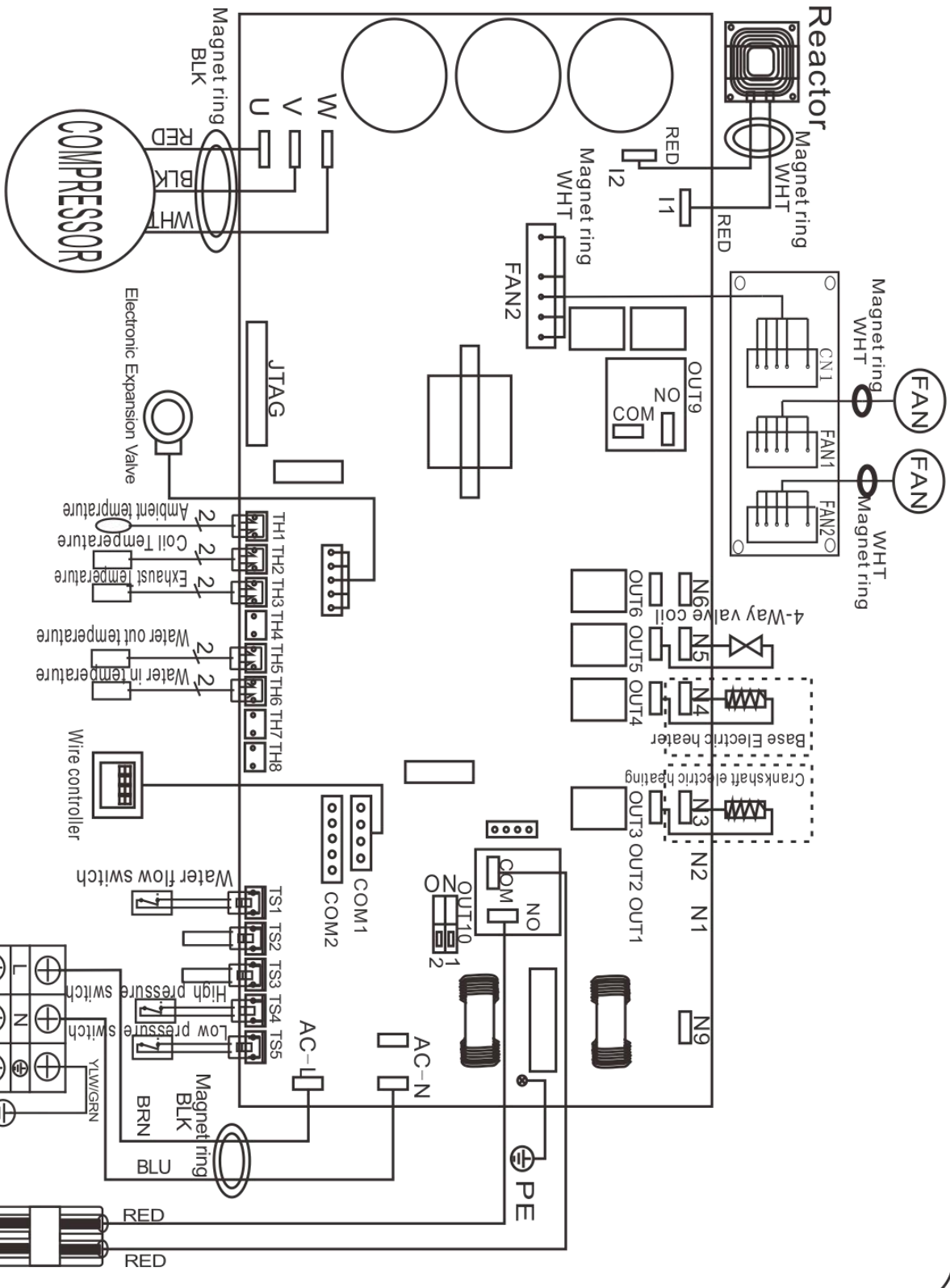

Power Supply  
220V-240V~50HZ

SWITCH  
(Water Pump)



# I-5101

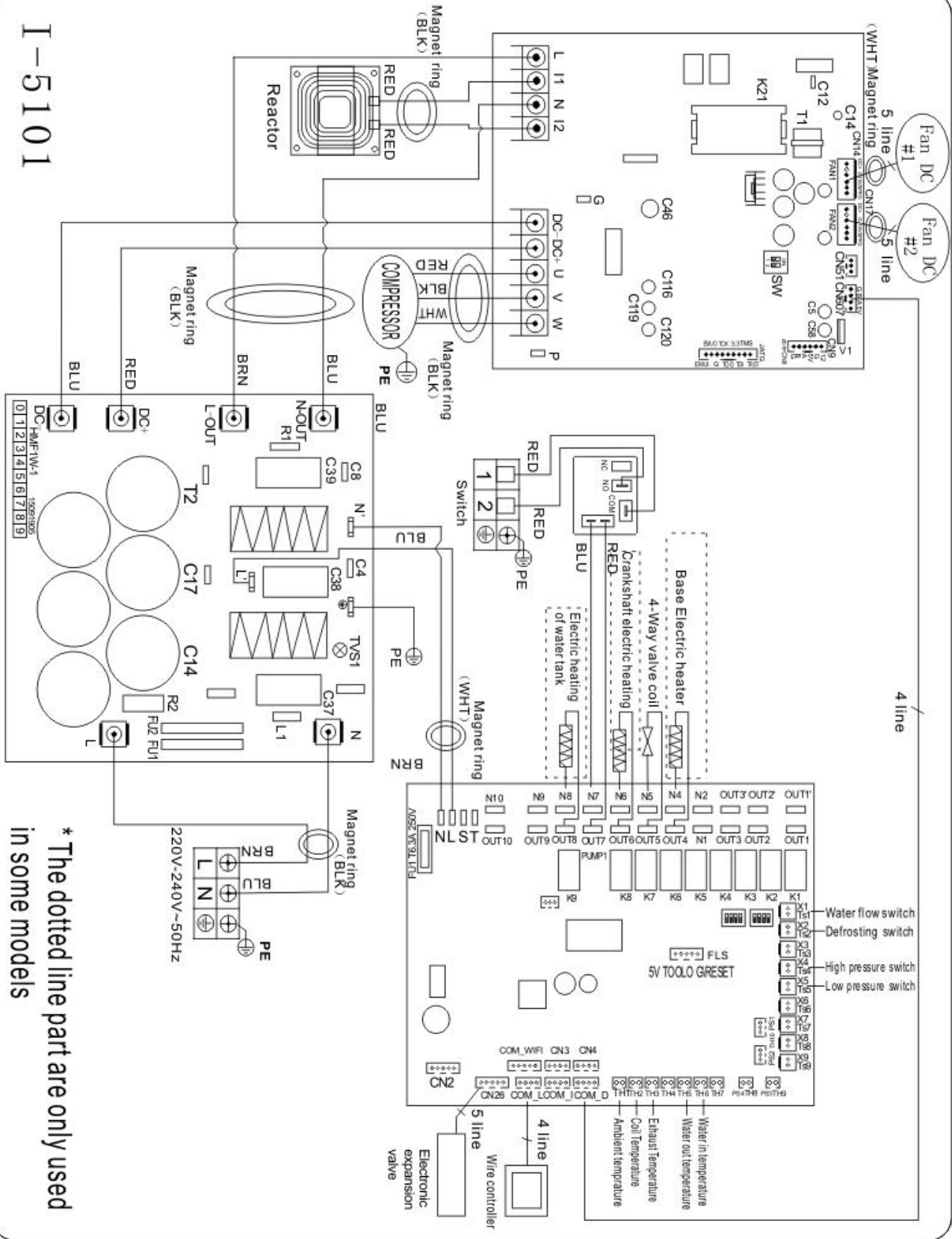

\* The dotted line part are only used in some models

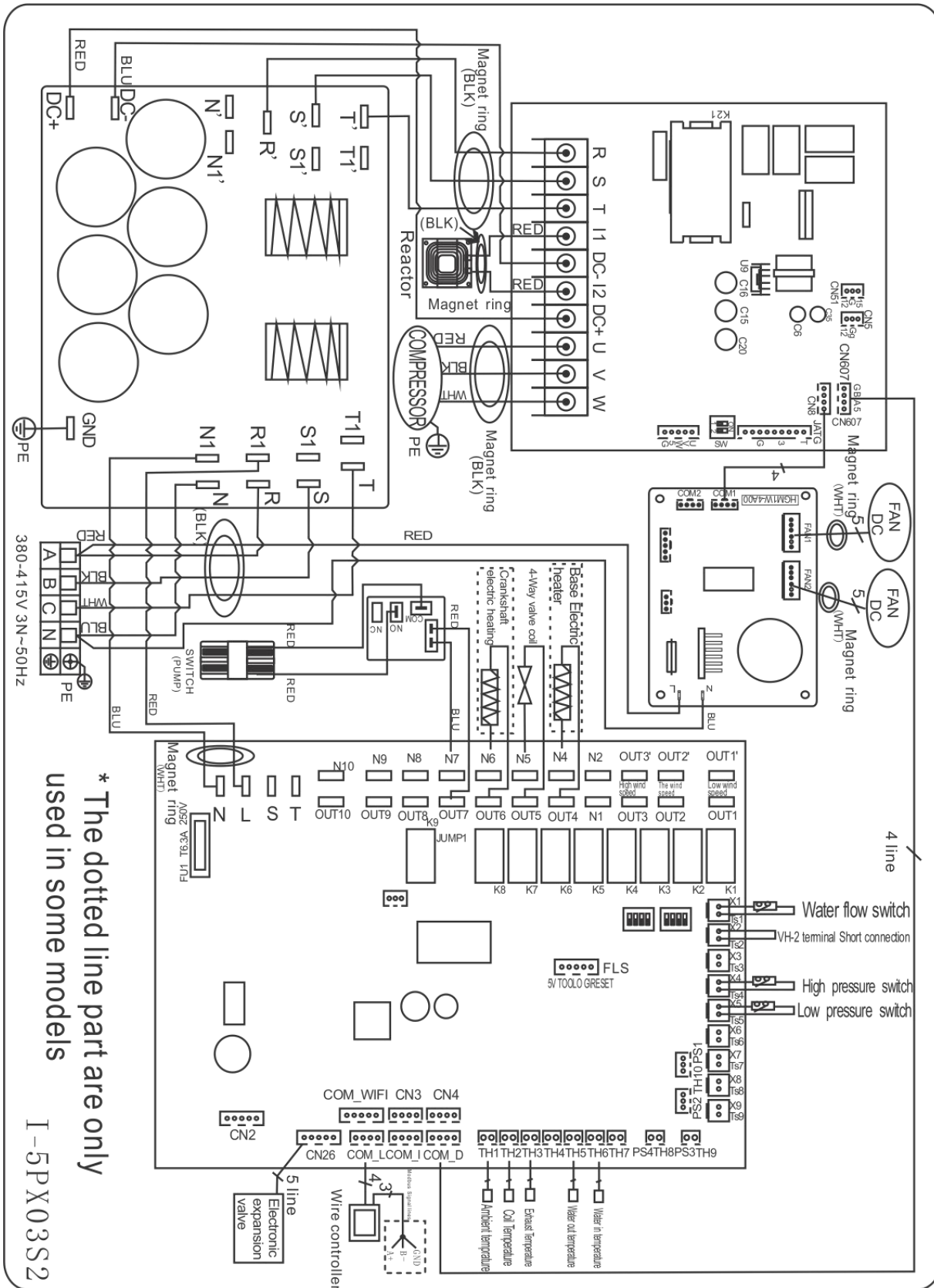

**NOTE:**

- (1) Above electrical wiring diagram only for your reference, please subject machine posted the wiring diagram.
- (2) The swimming pool heat pump must be connected ground wire well, although the unit heat exchanger is electrically isolated from the rest of the unit. Grounding the unit is still required to protect you against short circuits inside the unit. Bonding is also required.

**Disconnect:** A disconnect means (circuit breaker, fused or un-fused switch) should be located within sight of and readily accessible from the unit. This is common practice on commercial and residential heat pumps. It prevents remotely - energizing unattended equipment and permits turning off power at the unit while the unit is being serviced.

## 8. Maintenance

- (1) You should check the water supply system regularly to avoid the air entering the system and occurrence of low water flow, because it would reduce the performance and reliability of HP unit.
- (2) Clean your pools and filtration system regularly to avoid the damage of the unit as a result of the dirty or clogged filter.
- (3) You should discharge the water from bottom of water pump if HP unit will stop running for a long time (specially during the winter season).
- (4) In another way, you should check the unit is water fully before the unit start to run again.
- (5) After the unit is conditioned for the winter season, it is recommended to cover the heat pump with special winter heat pump.
- (6) When the unit is running, there is all the time a little water discharge under the unit.

# 9. Exploded view

UX11Csi32/UX14Csi32

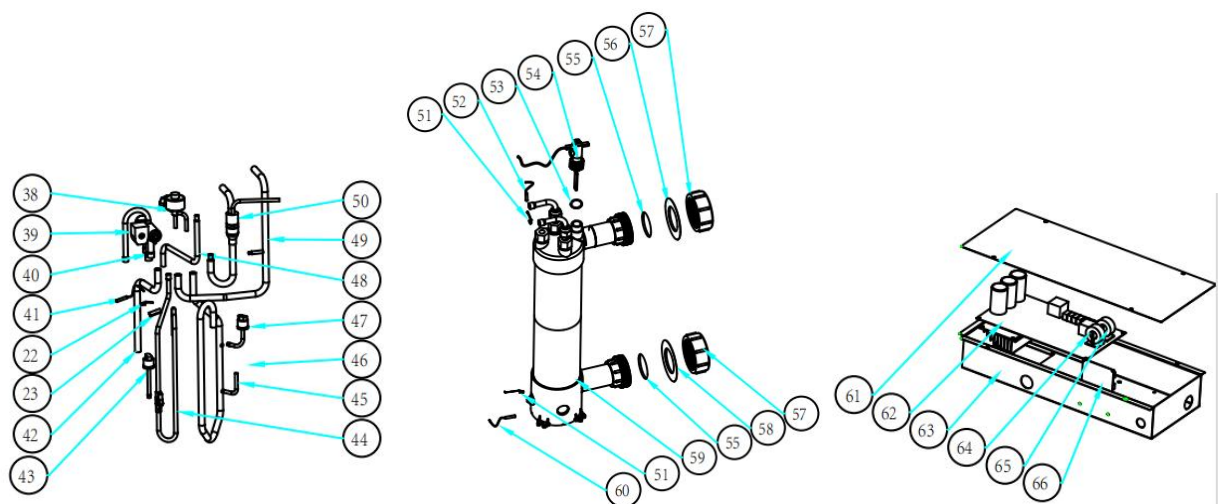
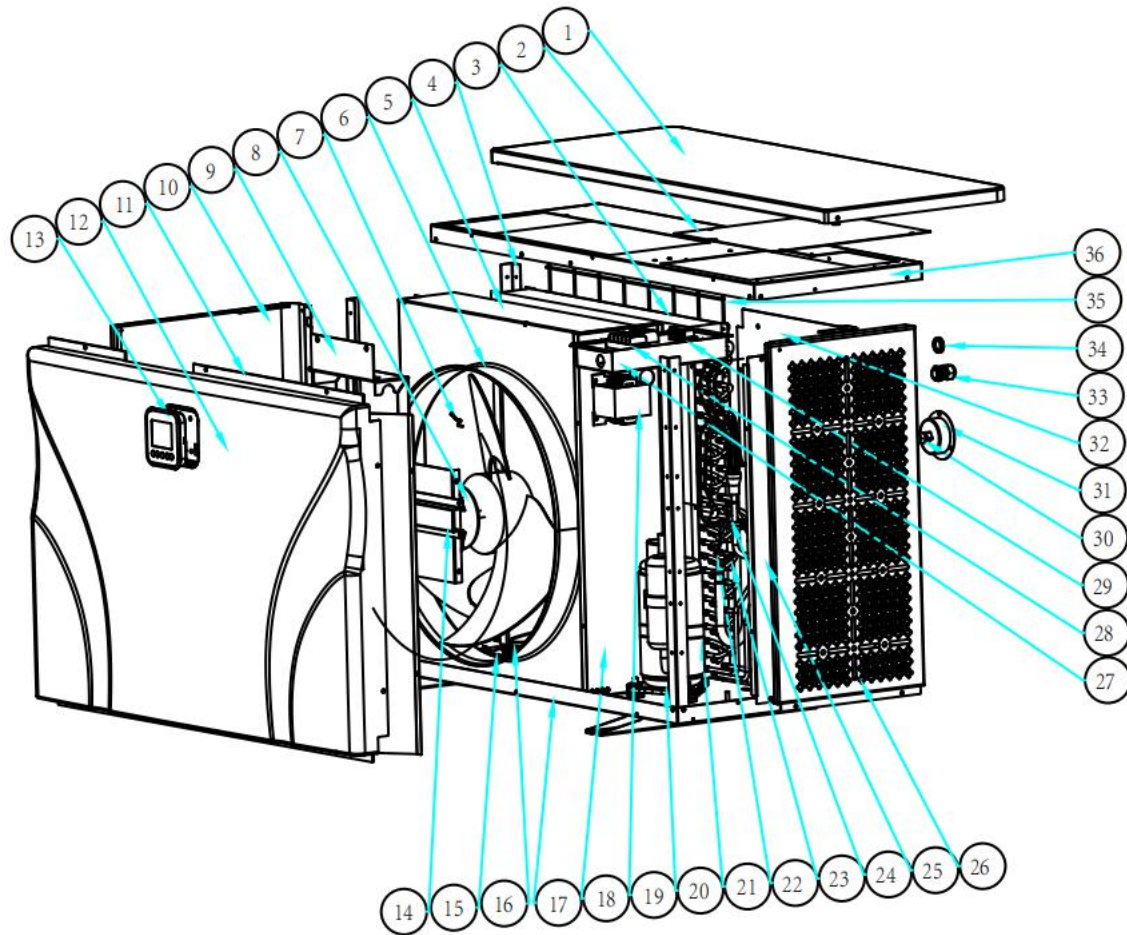

**UX11Csi32**

NO.	ERP	Part name	NO.	ERP	Part name
1	109060056	Top cover	34	136020119	Cable passing hole
2	109060053	Service panel	35	109060017	Back grill
3	103000335	Evaporator	36	109060051	Top frame
4	109060052	Pillar	37	119000058	EEV
5	109060023	Fan panel	38	121000037	4 way valve coil
6	117110063	Ambient temp. sensor T5-TH1	39	121000034	4 way valve
7	132000015	Fan blade	40	117110050	Evaporator temperature sensor T3-TH2
8	112000031	Fan motor	41	113060188	4-way valve to evaporator piping
9	109060027	Fan motor bracket	42	116000066	High pressure switch
10	109060058	Left panel	43	113020623	Discharge pipe
11	109060042	Service panel	44	113020579	Gas return piping
12	133470001	Front panel	45	/	Seal tube
13	117020293	Controller	46	116000071	Low pressure switch
14	109060054	Pillar	47	113080123	EEV to distribution piping
15	109060004	Evaporator support panel	48	113030214	4-way valve to exchanger
16	142000142	Evaporator heating resistor	49	113070067	Exchanger to EEV
17	109060050	Base tray	50	108010025	Exchanger temperature sensor clip
18	109060059	Isolation panel	51	117110057	Water outlet temp. sensor T2-TH5
19	117230003	Reactor	52	136010072	Rubber ring on water flow switch
20	101000188	Compressor	53	116000103	Water flow switch
21	142000072	Compressor heating resistor	54	133020007	PVC cover
22	113190007	Sensor clip	55	133020012	Red rubber ring
23	113190001	Sensor holder	56	102050004	Water connection sets
24	117110061	Discharge temp. sensor T6-TH3	57	133020012	Red rubber ring
25	109060044	Service panel	58	102041113	Titanium heat exchanger
26	109060057	Right panel	59	117110053	Water inlet temp. sensor T1-TH6
27	108960058	Terminal board	60	109060007	Electric box cover
28	115000004	Power terminal	61	117100079	PCB
29	136010004	Clip	62	109060039	Electric box
30	124020011	Screw	63	117240002	Magnet ring
31	106000012	Pressure gauge	64	117240003	Magnet ring
32	109060055	Back panel	65	117010122	Wifi module
33	110000039	Cable connector			

**UX14CsI32**

NO.	ERP	Part name	NO.	ERP	Part name
1	109060056	Top cover	34	136020119	Cable passing hole
2	109060053	Service panel	35	109060017	Back grill
3	103000335	Evaporator	36	109060051	Top frame
4	109060052	Pillar	37	119000058	EEV
5	109060023	Fan panel	38	121000037	4 way valve coil
6	117110063	Ambient temp. sensor T5-TH1	39	121000034	4 way valve
7	132000015	Fan blade	40	117110050	Evaporator temperature sensor T3-TH2
8	112000031	Fan motor	41	113060188	4-way valve to evaporator piping
9	109060027	Fan motor bracket	42	116000066	High pressure switch
10	109060058	Left panel	43	113020623	Discharge pipe
11	109060042	Service panel	44	113020693	Gas return piping
12	133470001	Front panel	45	/	Seal tube
13	117020293	Controller	46	116000071	Low pressure switch
14	109060054	Pillar	47	113080123	EEV to distribution piping
15	109060004	Evaporator support panel	48	113030214	4-way valve to exchanger
16	142000142	Evaporator heating resistor	49	113070067	Exchanger to EEV
17	109060050	Base tray	50	108010025	Exchanger temperature sensor clip
18	109060059	Isolation panel	51	117110057	Water outlet temp. sensor T2-TH5
19	117230003	Reactor	52	136010072	Rubber ring on water flow switch
20	101000188	Compressor	53	116000103	Water flow switch
21	142000072	Compressor heating resistor	54	133020007	PVC cover
22	113190007	Sensor clip	55	133020012	Red rubber ring
23	113190001	Sensor holder	56	102050004	Water connection sets
24	117110061	Discharge temp. sensor T6-TH3	57	133020012	Red rubber ring
25	109060044	Service panel	58	102041138	Titanium heat exchanger
26	109060057	Right panel	59	117110053	Water inlet temp. sensor T1-TH6
27	108960058	Terminal board	60	109060007	Electric box cover
28	115000004	Power terminal	61	117100076	PCB
29	136010004	Clip	62	109060039	Electric box
30	124020011	Screw	63	117240002	Magnet ring
31	106000012	Pressure gauge	64	117240003	Magnet ring
32	109060055	Back panel	65	117010122	Wifi module
33	110000039	Cable connector			

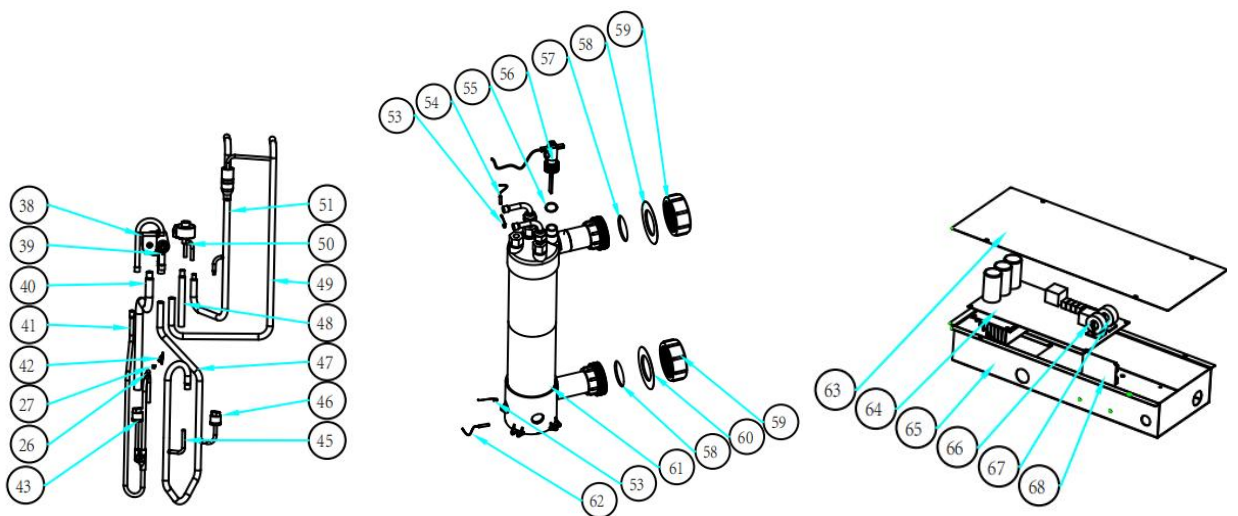
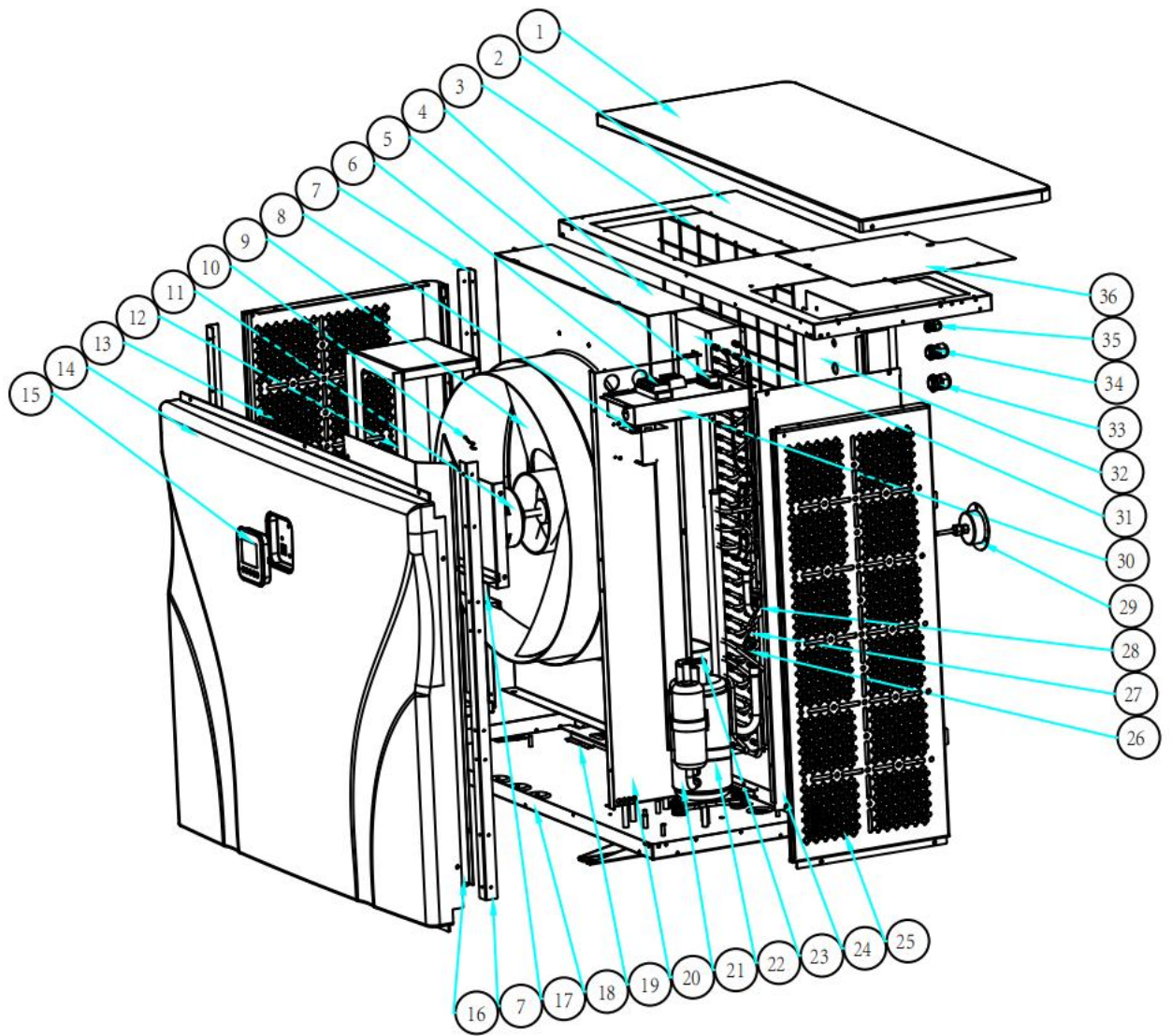

**UX17Csi32**

NO.	ERP	Part name	NO.	ERP	Part name
1	108960050	Top cover	35	110000036	Cable connector
2	108960057	Top frame	36	108960053	Service panel
3	108840091	Back grill	37	/	/
4	108960061	Fan panel	38	121000037	4 way valve coil
5	136010004	Clip	39	121000034	4 way valve
6	115000004	Power terminal	40	113060208	4-way valve to evaporator piping
7	108960037	Pillar	41	113010440	Discharge pipe
8	117230003	Reactor	42	117110050	Evaporator temperature sensor T3-TH2
9	132000023	Fan blade	43	116000067	High pressure switch
10	112000031	Fan motor	44	/	/
11	117110063	Ambient temp. sensor T5-TH1	45	/	Seal tube
12	108960060	Fan motor bracket	46	116000073	Low pressure switch
13	108960073	Left panel	47	113020673	Gas return piping
14	133450001	Front panel	48	113080128	EEV to distribution piping
15	117020293	Controller	49	113030212	4-way valve to exchanger
16	108960062	Service panel	50	119000058	EEV
17	108960052	Pillar	51	113070065	Exchanger to EEV
18	108960074	Base tray	52	/	/
19	108960002	Evaporator support panel	53	108010025	Exchanger temperature sensor clip
20	108960063	Isolation panel	54	117110057	Water outlet temp. sensor T2-TH5
21	101000181	Compressor	55	136010072	Rubber ring on water flow switch
22	142000074	Compressor heating resistor	56	116000065	Water flow switch
23	142000142	Evaporator heating resistor	57	133020007	PVC cover
24	108960065	Service panel	58	133020012	Red rubber ring
25	108960072	Right panel	59	102050004	Water connection sets
26	113190001	Sensor holder	60	133020011	Blue rubber ring
27	113190007	Clip	61	102041110	Titanium heat exchanger
28	117110061	Discharge temp. sensor T6-TH3	62	117110053	Water inlet temp. sensor T1-TH6
29	106000012	Pressure gauge	63	108960007	Electric box cover
30	108960058	Terminal board	64	117100076	PCB
31	103000360	Evaporator	65	108960054	Electric box
32	108960075	Back panel	66	117240002	Magnet ring
33	110000048	Cable connector	67	117240003	Magnet ring
34	110000039	Cable connector	68	117010122	Wifi module



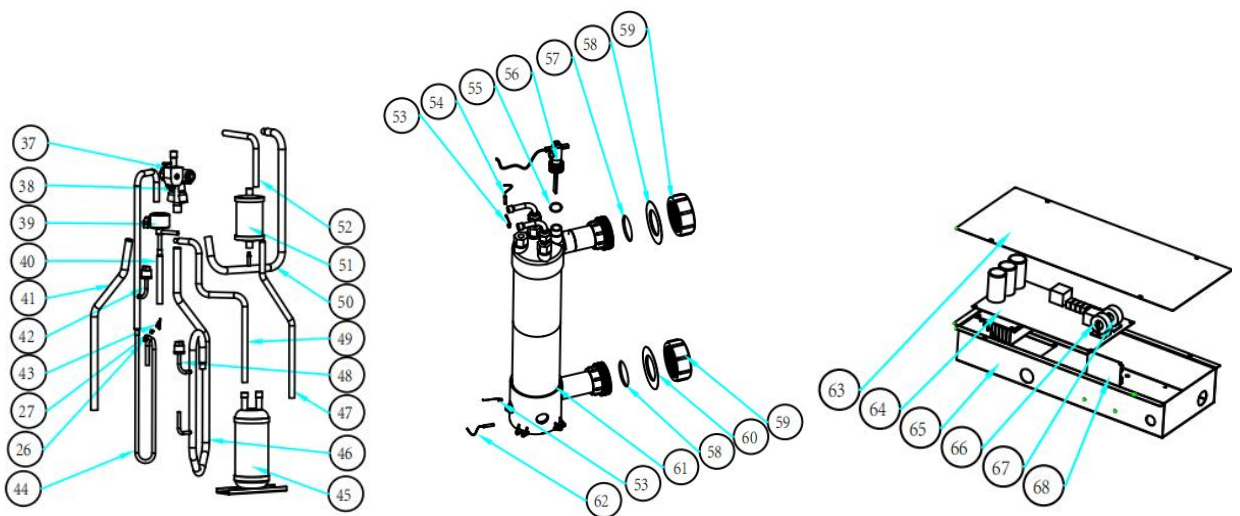
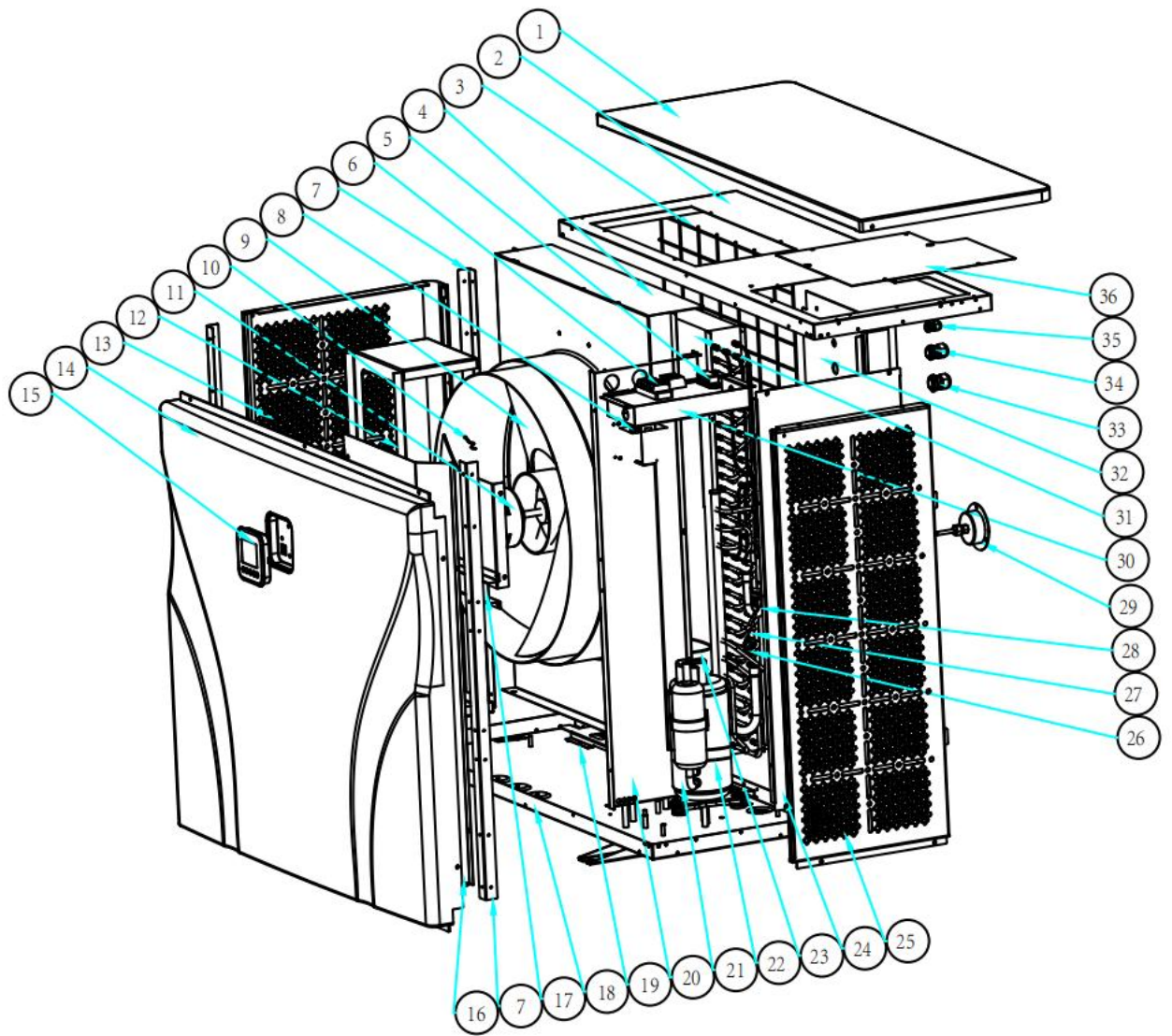

**UX21Csi32**

NO.	ERP	Part name	NO.	ERP	Part name
1	108960050	Top cover	35	110000036	Cable connector
2	108960057	Top frame	36	108960053	Service panel
3	108840091	Back grill	37	121000028	4 way valve
4	108960061	Fan panel	38	121000037	4 way valve coil
5	136010004	Clip	39	119000066	EEV
6	115000004	Power terminal	40	113080128	EEV to distribution piping
7	108960037	Pillar	41	113060193	4-way valve to evaporator piping
8	117230003	Reactor	42	116000068	High pressure switch
9	132000023	Fan blade	43	117110050	Evaporator temperature sensor T3-TH2
10	112000031	Fan motor	44	113010434	Discharge pipe
11	117110063	Ambient temp. sensor T5-TH1	45	105000004	Liquid storage tank
12	108960060	Fan motor bracket	46	113020683	Gas return piping
13	108960073	Left panel	47	113130041	Filter to storage tank
14	133450001	Front panel	48	116000073	Low pressure switch
15	117020293	Controller	49	113120065	Liquid storage tank to EEV
16	108960062	Service panel	50	113030216	4-way valve to exchanger
17	108960052	Pillar	51	120000066	Dehydrator filter
18	108960079	Base tray	52	113170079	Exchanger to filter
19	108960002	Evaporator support panel	53	108010025	Exchanger temperature sensor clip
20	108960063	Isolation panel	54	117110057	Water outlet temp. sensor T2-TH5
21	101000252	Compressor	55	136010072	Rubber ring on water flow switch
22	142000072	Compressor heating resistor	56	116000065	Water flow switch
23	142000142	Evaporator heating resistor	57	133020007	PVC cover
24	108960065	Service panel	58	133020012	Red rubber ring
25	108960072	Right panel	59	102050004	Water connection sets
26	113190001	Sensor holder	60	133020011	Blue rubber ring
27	113190007	Clip	61	102041110	Titanium heat exchanger
28	117110061	Discharge temp. sensor T6-TH3	62	117110053	Water inlet temp. sensor T1-TH6
29	106000012	Pressure gauge	63	108960007	Electric box cover
30	108960058	Terminal board	64	117100076	PCB
31	103000337	Evaporator	65	108960054	Electric box
32	108960075	Back panel	66	117240002	Magnet ring
33	110000048	Cable connector	67	117240003	Magnet ring
34	110000039	Cable connector	68	117010122	Wifi module

UX30Csi32/UX30Csi32T/UX35Csi32T

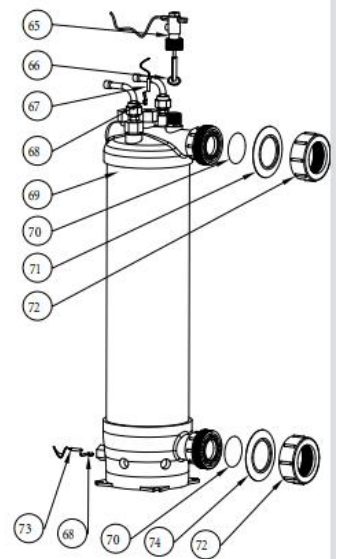
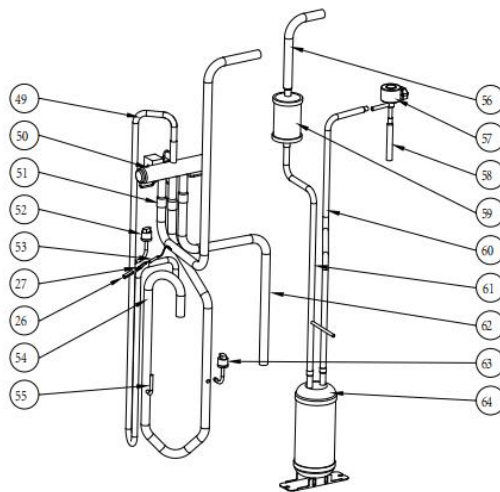
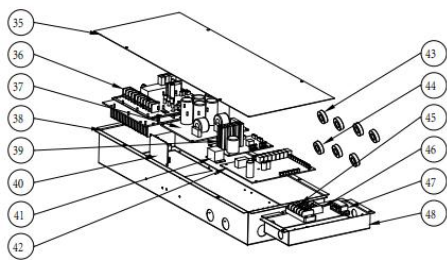
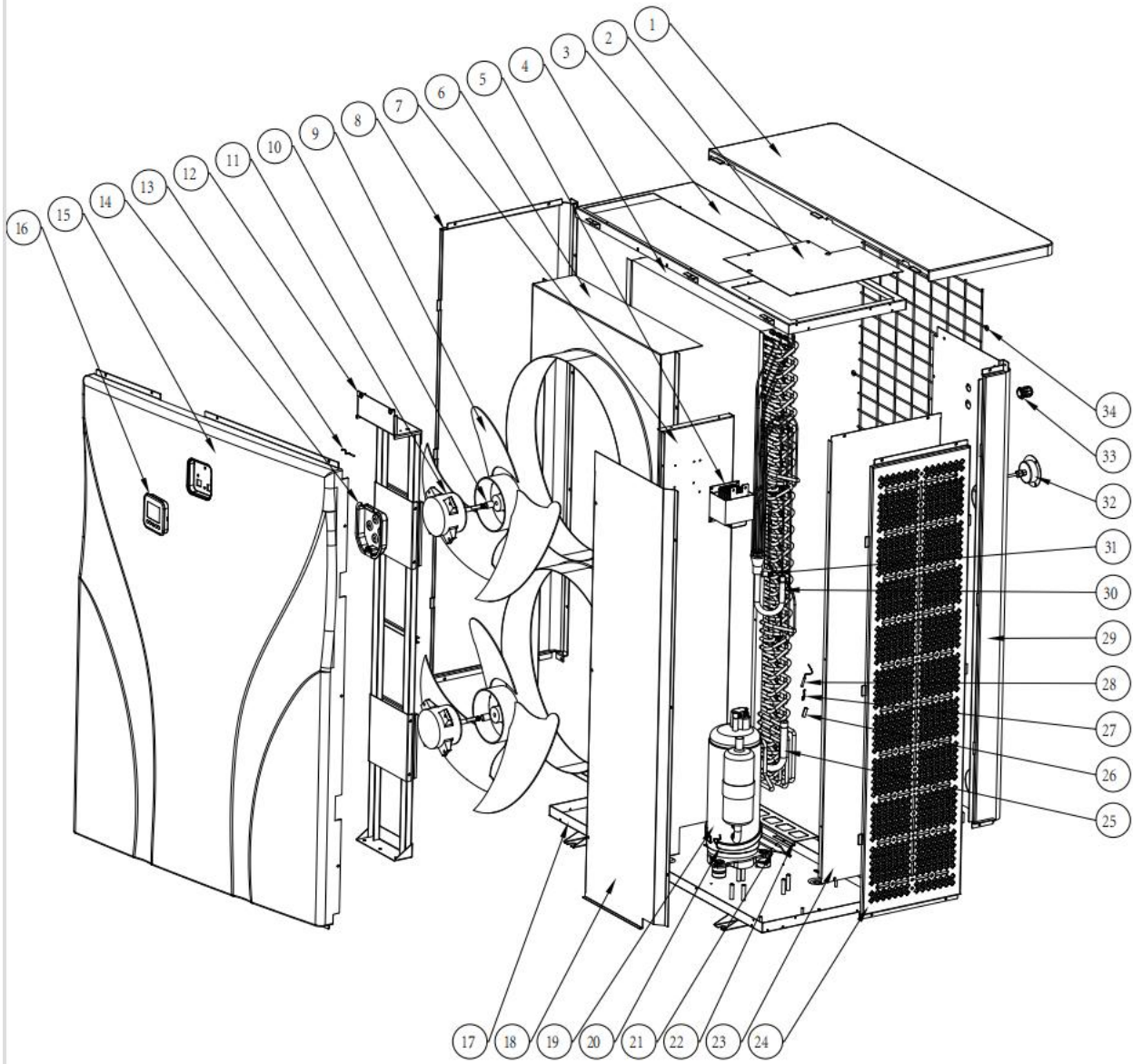

**UX30Csi32**

NO.	ERP	Part name	NO.	ERP	Part name
1	109070060	Top cover	38	109070006	Electric box
2	109070052	Service panel	39	/	/
3	109070051	Top frame	40	117010122	Wifi module
4	103000331	Evaporator	41	142000038	Relay
5	117230002	Reactor	42	117250021	PCB
6	109070019	Fan panel	43	117240002	Magnet ring
7	109070026	Isolation panel	44	117240003	Magnet ring
8	109070057	Left panel	45	115000025	Power terminal
9	132000023	Fan blade	46	115000023	Power terminal
10	108010024	Fan motor assembly	47	136010004	Clip
11	112000031	Fan motor	48	108960058	Terminal board
12	109070021	Fan motor bracket	49	113010444	Discharge pipe
13	117110063	Ambient temp. sensor T5-TH1	50	121000028	4 way valve
14	133030020	Controller installation box	51	113030183	4-way valve to exchanger
15	133460001	Front panel	52	116000068	High pressure switch
16	117020293	Controller	53	117110051	Discharge temp. sensor T6-TH3
17	109070065	Base tray	54	113020684	Gas return piping
18	109070053	Service panel	55	113020685	Seal tube
19	101000185	Compressor	56	113070061	Exchanger to filter
20	142000077	Compressor heating resistor	57	119000061	EEV
21	142000079	Evaporator heating resistor	58	113080116	EEV to distribution piping
22	109070004	Evaporator support panel	59	120000066	Dehydrator filter
23	109070054	Service panel	60	113120053	Liquid storage tank to EEV
24	109070058	Right panel	61	113130039	Filter to storage tank
25	103000331	Evaporator pipe	62	113060214	4-way valve to evaporator piping
26	113190001	Sensor holder	63	116000073	Low pressure switch
27	113190007	Sensor clip	64	105000015	Liquid storage tank
28	117110050	Evaporator temperature sensor T3-TH2	65	116000065	Water flow switch
29	109070062	Back panel	66	136020083	Rubber ring on water flow switch
30	103000331	Distribution piping	67	117110057	Water outlet temp. sensor T2-TH5
31	136020005	Rubber block	68	108010025	Exchanger temperature sensor clip
32	106000012	Pressure gauge	69	102041106	Titanium heat exchanger
33	110000038	Cable connector	70	133020006	Rubber ring on water connection
34	109070022	Back grill	71	133020012	Red rubber ring
35	109070007	Electric box cover	72	102050004	Water connection sets
36	117140016	Driver board 3 phase	73	117110053	Water inlet temp. sensor T1-TH6
37	117260001	Filter board	74	133020011	Blue rubber ring

**UX30Csi32T**

NO.	ERP	Part name	NO.	ERP	Part name
1	109070060	Top cover	38	109070006	Electric box
2	109070052	Service panel	39	/	/
3	109070051	Top frame	40	117010122	Wifi module
4	103000331	Evaporator	41	142000038	Relay
5	117230002	Reactor	42	117250022	PCB
6	109070019	Fan panel	43	117240002	Magnet ring
7	109070068	Isolation panel	44	117240003	Magnet ring
8	109070070	Left panel	45	115000006	Power terminal
9	132000023	Fan blade	46	115000023	Power terminal
10	108010024	Fan motor assembly	47	136010004	Clip
11	112000031	Fan motor	48	108960058	Terminal board
12	109070021	Fan motor bracket	49	113020636	Discharge pipe
13	117110063	Ambient temp. sensor T5-TH1	50	121000028	4 way valve
14	133030020	Controller installation box	51	113030183	4-way valve to exchanger
15	133460001	Front panel	52	116000068	High pressure switch
16	117020293	Controller	53	117110051	Discharge temp. sensor T6-TH3
17	180060001	Base tray	54	113020697	Gas return piping
18	109070069	Service panel	55	/	Seal tube
19	101000239	Compressor	56	113070061	Exchanger to filter
20	142000077	Compressor heating resistor	57	119000061	EEV
21	142000079	Evaporator heating resistor	58	113080116	EEV to distribution piping
22	109070004	Evaporator support panel	59	120000066	Dehydrator filter
23	109070066	Service panel	60	113120053	Liquid storage tank to EEV
24	109070058	Right panel	61	113130039	Filter to storage tank
25	103000331	Evaporator pipe	62	113060214	4-way valve to evaporator piping
26	113190001	Sensor holder	63	116000073	Low pressure switch
27	113190007	Sensor clip	64	105000015	Liquid storage tank
28	117110050	Evaporator temperature sensor T3-TH2	65	116000065	Water flow switch
29	109070062	Back panel	66	136020083	Rubber ring on water flow switch
30	103000331	Distribution piping	67	117110057	Water outlet temp. sensor T2-TH5
31	136020005	Rubber block	68	108010025	Exchanger temperature sensor clip
32	106000012	Pressure gauge	69	102041106	Titanium heat exchanger
33	110000038	Cable connector	70	133020006	Rubber ring on water connection
34	109070022	Back grill	71	133020012	Red rubber ring
35	109070007	Electric box cover	72	102050004	Water connection sets
36	117140019	Driver board 3 phase	73	117110053	Water inlet temp. sensor T1-TH6
37	117260002	Filter board	74	133020011	Blue rubber ring

**UX35Csi32T**

NO.	ERP	Part name	NO.	ERP	Part name
1	109070060	Top cover	38	109070006	Electric box
2	109070052	Service panel	39	/	/
3	109070051	Top frame	40	117010122	Wifi module
4	103000356	Evaporator	41	142000038	Relay
5	117230002	Reactor	42	117250022	PCB
6	109070019	Fan panel	43	117240002	Magnet ring
7	109070068	Isolation panel	44	117240003	Magnet ring
8	109070070	Left panel	45	115000006	Power terminal
9	132000023	Fan blade	46	115000023	Power terminal
10	108010024	Fan motor assembly	47	136010004	Clip
11	112000031	Fan motor	48	108960058	Terminal board
12	109070021	Fan motor bracket	49	113020636	Discharge pipe
13	117110063	Ambient temp. sensor T5-TH1	50	121000028	4 way valve
14	133030020	Controller installation box	51	113030183	4-way valve to exchanger
15	133460001	Front panel	52	116000068	High pressure switch
16	117020293	Controller	53	117110051	Discharge temp. sensor T6-TH3
17	180060001	Base tray	54	113020697	Gas return piping
18	109070069	Service panel	55	/	Seal tube
19	101000239	Compressor	56	113070061	Exchanger to filter
20	142000077	Compressor heating resistor	57	119000061	EEV
21	142000079	Evaporator heating resistor	58	113080116	EEV to distribution piping
22	109070004	Evaporator support panel	59	120000066	Dehydrator filter
23	109070066	Service panel	60	113120053	Liquid storage tank to EEV
24	109070058	Right panel	61	113130039	Filter to storage tank
25	103000356	Evaporator pipe	62	113060214	4-way valve to evaporator piping
26	113190001	Sensor holder	63	116000073	Low pressure switch
27	113190007	Sensor clip	64	105000015	Liquid storage tank
28	117110050	Evaporator temperature sensor T3-TH2	65	116000065	Water flow switch
29	109070062	Back panel	66	136020083	Rubber ring on water flow switch
30	103000356	Distribution piping	67	117110057	Water outlet temp. sensor T2-TH5
31	136020005	Rubber block	68	108010025	Exchanger temperature sensor clip
32	106000012	Pressure gauge	69	102041106	Titanium heat exchanger
33	110000038	Cable connector	70	133020006	Rubber ring on water connection
34	109070022	Back grill	71	133020012	Red rubber ring
35	109070007	Electric box cover	72	102050004	Water connection sets
36	117140019	Driver board 3 phase	73	117110053	Water inlet temp. sensor T1-TH6
37	117260002	Filter board	74	133020011	Blue rubber ring

# **Manuel d'installation et d'utilisation**

## **INVERBOOST INVERTER**

## Règlement (UE) n° 517/2014 du 16/04/14 relatif aux gaz à effet de serre fluorés et abrogeant le règlement (CE) n° 842/2006

### Contrôles d'étanchéité

1. Les exploitants d'équipements qui contiennent des gaz à effet de serre fluorés dans des quantités supérieures ou égales à 5 tonnes équivalent CO<sub>2</sub>, veillent à ce que ces équipements fassent l'objet de contrôles d'étanchéité.
2. Au 1 janvier 2017 les contrôles d'étanchéité sont à effectuer au moins tous les douze mois, pour les équipements dans des quantités supérieures ou égales à 5 tonnes équivalent CO<sub>2</sub> mais inférieures à 50 tonnes équivalent CO<sub>2</sub>.

### Tableau des équivalences CO<sub>2</sub>

1. Charge en kg et Tonnes équivalent CO<sub>2</sub>.

Charge et Tonnes équivalent CO <sub>2</sub>	Fréquence du contrôle
De 7 à 75 kg de charge soit de 5 à 50 Tonnes	Tous les ans

**Pour le Gaz R32, 7.40kg équivalences à 5 tonnes de CO<sub>2</sub> donc devoir de vérifier tous les ans.**

### Formation et certification

1. L'exploitant veille à ce que le personnel concerné ait obtenu la **certification nécessaire**, qui implique une connaissance appropriée des règlements et des normes applicables ainsi que la compétence nécessaire en termes de prévention d'émission, de récupération des gaz à effet de serre fluorés, de manipulation sans danger pour les contrôles d'étanchéité de l'équipement.

### Tenue de registres

1. Les exploitants d'équipements qui doivent faire l'objet d'un contrôle d'étanchéité établissent et tiennent à jour, pour chaque pièce de ces équipements, des registres dans lesquels ils consignent les informations suivantes :

- a) La quantité et le type de gaz à effet de serre fluorés installés;
- b) Les quantités de gaz ajoutées pendant l'installation, la maintenance ou l'entretien ou à cause d'une fuite;
- c) La quantité de gaz installés qui a été éventuellement recyclée ou régénérée, y compris le nom et l'adresse de l'installation de recyclage ou de régénération et, le cas échéant, le numéro de certificat;
- d) La quantité de gaz récupérée;
- e) L'identité de l'entreprise qui a assuré l'installation, l'entretien, la maintenance et, le cas échéant, la réparation ou la mise hors service de l'équipement, y compris, le cas échéant, le numéro de son certificat;
- f) Les dates et les résultats des contrôles effectués;
- g) Si l'équipement a été mis hors service, les mesures prises pour récupérer et éliminer les gaz.

2. **Les exploitants conservent les registres visés audit paragraphe pendant au moins cinq ans, les entreprises exécutant les activités pour le compte des exploitants conservent des copies des registres visés au paragraphe 1 pendant au moins cinq ans.**



## Sommaire

1. Caractéristiques Techniques
2. Dimension
3. Installation et connexion
4. Regolazione del bypass
5. Funcionamiento del controlador
6. Guide de dépannage
7. Câblage Electrique
8. Entretien
9. Schéma éclaté et entretien

Nous vous remercions d'avoir choisi la pompe à chaleur de piscine INVERBOOST PX pour votre piscine. Elle va chauffer l'eau de votre piscine et la maintenir à une température constante lorsque la température ambiante varie de -20°C à 43°C.

Nous avons accordé notre plus grande attention à la réalisation de ce manuel afin que vous puissiez mettre en œuvre votre pompe à chaleur dans de bonnes conditions. Malgré cela, si vous avez besoin d'aide, notre service technique, se tient à votre disposition.

### **ATTENTION : Ce manuel contient toutes les informations nécessaires à l'utilisation et à l'installation de votre pompe à chaleur.**

L'installateur doit lire le manuel et suivre attentivement les instructions d'utilisation, de mise en œuvre et de sécurité du produit.

L'installateur est responsable de l'installation de l'appareil, du respect des instructions du fabricant et de la réglementation en vigueur. Le non-respect de ce manuel implique l'exclusion de toute garantie.

Le fabricant décline toute responsabilité des dommages occasionnés aux personnes, objets et des erreurs dues à l'installation dans de mauvaises conditions.

Toute utilisation à des fins non conformes à celles qui sont à l'origine de sa fabrication sera considérée comme dangereuse.

### **ALERTE**

1. **Vous devez vidanger l'eau de pompe à chaleur pour empêcher les dommages du gel au cours de l'hiver ou pendant une longue période d'inactivité.**
2. **Coupez systématiquement l'alimentation électrique lorsque vous intervenez et/ ou ouvrez l'unité.**
3. **Veuillez maintenir, s'il vous plaît, le contrôleur dans une zone sèche, ou bien le protéger par un boîtier de protection étanche, afin d'éviter de possibles dommages provoqués par l'humidité.**

# 1. Caractéristiques techniques

Model		UX11Csi32	UX14Csi32	UX17Csi32
<b>* Performance à l'air 28 °C, eau 28 °C, humidité 80%</b>				
Turbo Capacité de chauffage	kW	11.0	14.0	17.0
Smart Capacité de chauffage	kW	10.0	11.0	14.0
Consommation d'énergie	kW	1.55-0.17	1.97-0.22	2.39-0.27
C.O.P.		16-7.4	16-7.1	16-7.2
C.O.P. in Turbo Mode		7.4	7.1	7.2
C.O.P. at 50% capacity		11.8	11.0	11.8
<b>* Performance à l'air 15 °C, eau 26 °C, humidité 70%</b>				
Turbo Capacité de chauffage	kW	8.5	9.5	12.0
Smart Capacité de chauffage	kW	7.0	8.0	10.5
Consommation d'énergie	kW	1.67-0.26	1.90-0.29	2.31-0.37
C.O.P.		8.2-5.1	8.21-5	8.5-5.2
C.O.P. in Turbo		5.1	5.0	5.2
C.O.P. at 50% capacity		7.1	7.0	7.8
<b>* Données GENERALES</b>				
Type de compresseur		Inverter compressor		
Tension		220-240V/50Hz/1PH		
Courant évalué	A	6.9	8.7	10.6
Courant max	A	10.5	13.5	15.5
Fusible minimum	A	12.0	15.0	16.0
Flux d'eau conseillé	m³/h	3.7	4.0	5.0
Chute de pression de l'eau	Kpa	12.0	14.0	15.0
Échangeur de chaleur		Twist Titanium exchanger		
Connexion d'eau	mm	50		
Quantité de ventilateur		1		
Type de ventilation		Horizontal		
Niveau de bruit (10m)	dB(A)	17.8-26.2	21.7-26.7	22.6-28.1
Niveau de bruit (1m)	dB(A)	36-46.2	38-47.6	39.5-49.8
<b>* Dimension / Poids</b>				
Poids net	kg	73	78	98
Poids brut	kg	78	83	113
Dimension nette	mm	1028*441*685	1028*441*685	1073*492*886
Dimension d'emballage	mm	1095*525*830	1095*525*830	1140*555*1030

Model		UX21Csi32	UX26Csi32	UX30Csi32
<b>* Performance à l'air 28 °C, eau 28 °C, humidité 80%</b>				
Turbo Capacité de chauffage	kW	21.0	26.0	30.0
Smart Capacité de chauffage	kW	18.0	21.0	25.0
Consommation d'énergie	kW	2.96-0.33	3.66-0.29	4.17-0.47
C.O.P.		16-7.1	16-7.1	16-7.1
C.O.P. in Turbo Mode		7.1	7.1	7.1
C.O.P. at 50% capacity		11.2	11.2	11.2
<b>* Performance à l'air 15 °C, eau 26 °C, humidité 70%</b>				
Turbo Capacité de chauffage	kW	15.5	18.0	20.0
Smart Capacité de chauffage	kW	13.5	16.0	18.0
Consommation d'énergie	kW	3.04-0.47	3.53-0.55	3.92-0.61
C.O.P.		8.3-5.1	8.2-5.1	8.2-5.1
C.O.P. in Turbo		5.1	5.1	5.1
C.O.P. at 50% capacity		7.4	7.2	7.2
<b>* Données GENERALES</b>				
Type de compresseur		Inverter compressor		
Tension		220-240V/50Hz/1PH		
Courant évalué	A	13.1	16.3	18.5
Courant max	A	19.5	24.0	28.0
Fusible minimum	A	22	28	32
Flux d'eau conseillé	m³/h	6.0	8.0	10.0
Chute de pression de l'eau	Kpa	15	18	20
Échangeur de chaleur		Twist Titanium exchanger		
Connexion d'eau	mm	50		
Quantité de ventilateur		1	2	2
Type de ventilation		Horizontal		
Niveau de bruit (10m)	dB(A)	22.9-30.6	23.1-31.8	23.2-32.4
Niveau de bruit (1m)	dB(A)	40-51	41-51.6	42-51.8
<b>* Dimension / Poids</b>				
Poids net	kg	117	125	130
Poids brut	kg	135	145	148
Dimension nette	mm	1073*492*886	1039*509*1289	1113*519*1410
Dimension d'emballage	mm	1185*530*1030	1185*565*1435	1225*540*1555

Model		UX30Csi32T	UX35Csi32T
<b>* Performance à l'air 28 °C, eau 28 °C, humidité 80%</b>			
Turbo Capacité de chauffage	kW	30.0	35.0
Smart Capacité de chauffage	kW	25.0	30.0
Consommation d'énergie	kW	4.17-0.47	4.93-0.55
C.O.P.		16-7.1	16-7.1
C.O.P. in Turbo Mode		7.1	7.1
C.O.P. at 50% capacity		11.2	11.2
<b>* Performance à l'air 15 °C, eau 26 °C, humidité 70%</b>			
Turbo Capacité de chauffage	kW	20.0	24.0
Smart Capacité de chauffage	kW	18.0	22.0
Consommation d'énergie	kW	3.85-0.61	4.62-0.73
C.O.P.		8.2-5.2	8.2-5.2
C.O.P. in Turbo		5.2	5.2
C.O.P. at 50% capacity		7.2	7.2
<b>* Données GENERALES</b>			
Type de compresseur		Inverter compressor	
Tension		380V/50Hz/3PH	
Courant évalué	A	7.5	8.8
Courant max	A	12.0	14.0
Fusible minimum	A	15	17
Flux d'eau conseillé	m <sup>3</sup> /h	10.0	15.0
Chute de pression de l'eau	Kpa	20	25
Échangeur de chaleur		Twist Titanium exchanger	
Connexion d'eau	mm	50	
Quantité de ventilateur		2	2
Type de ventilation		Horizontal	
Niveau de bruit (10m)	dB(A)	23.2-32.4	23.4-32.8
Niveau de bruit (1m)	dB(A)	42-51.8	42.8-52
<b>* Dimension / Poids</b>			
Poids net	kg	130	135
Poids brut	kg	148	150
Dimension nette	mm	1113*519*1410	1113*519*1410
Dimension d'emballage	mm	1225*540*1555	1225*540*1555

## 2. Dimension (mm)

UX11Csi32/UX14Csi32

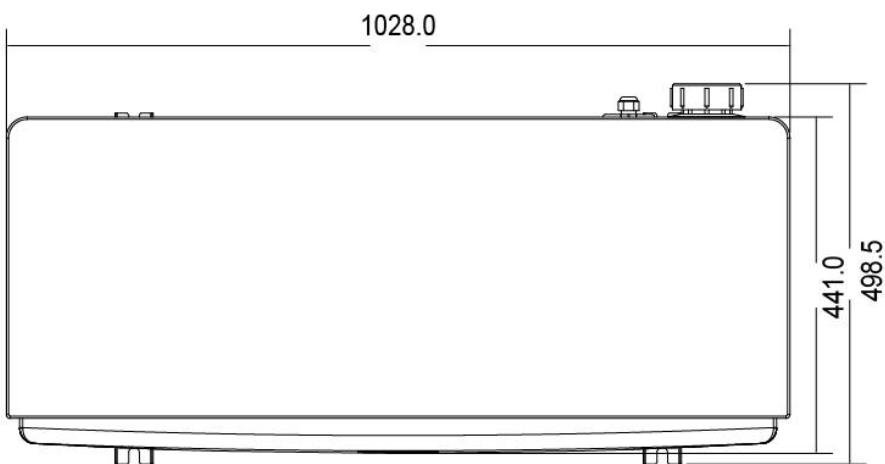
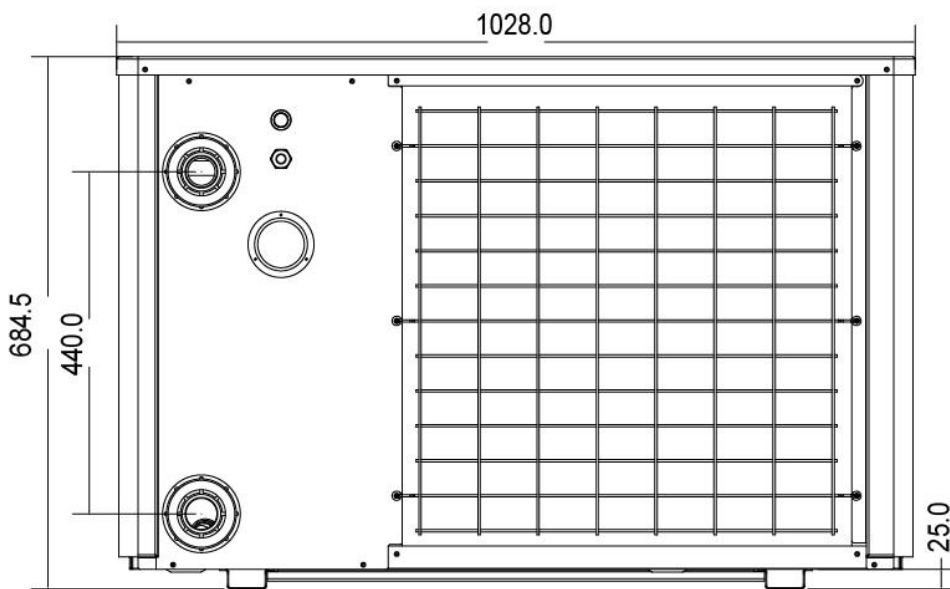
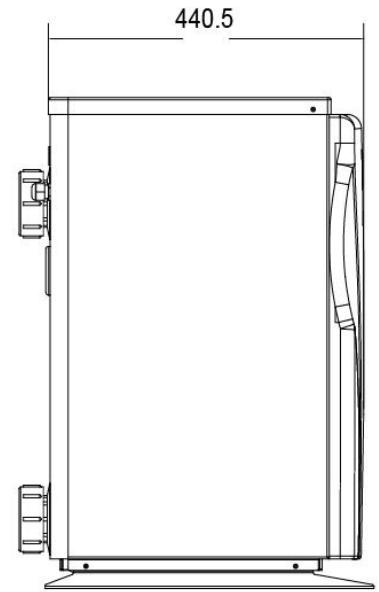
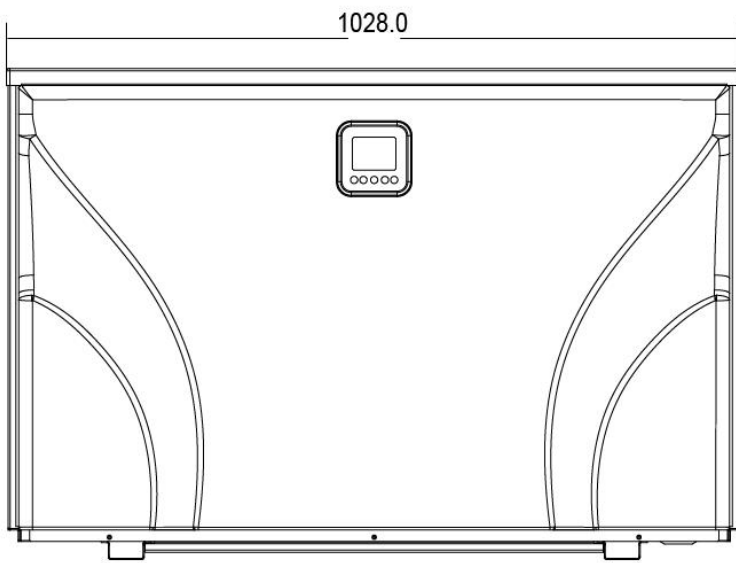

UX17Csi32/UX21Csi32

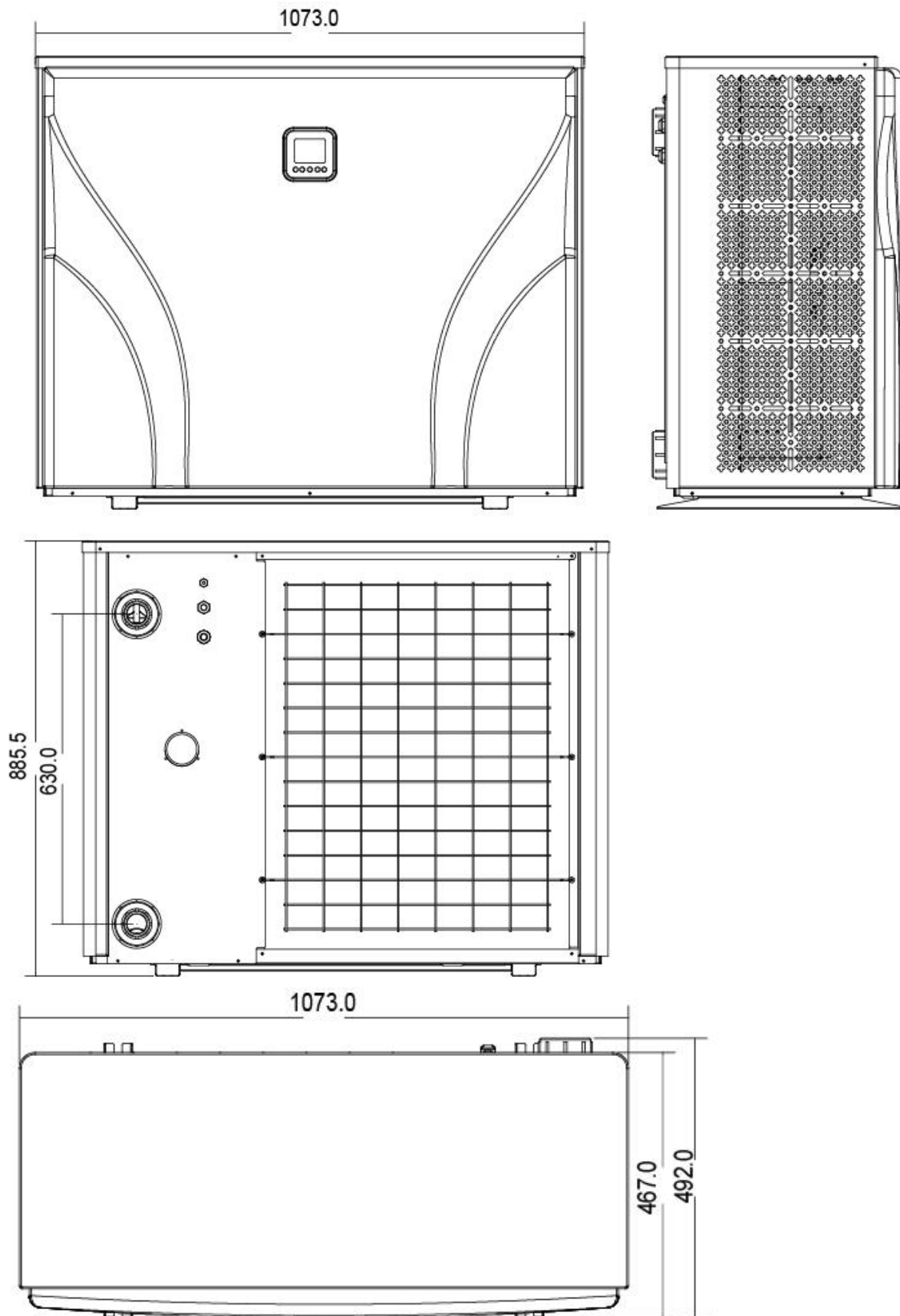

UX26Csi32

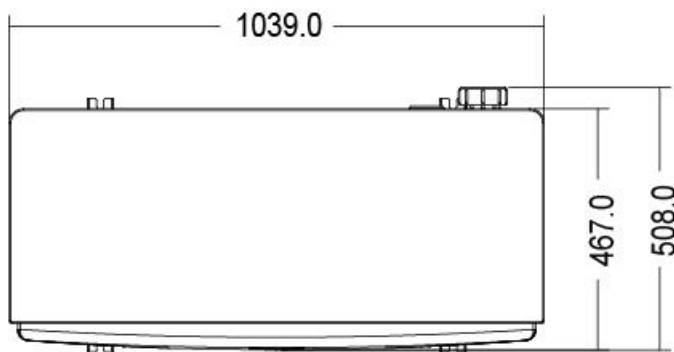
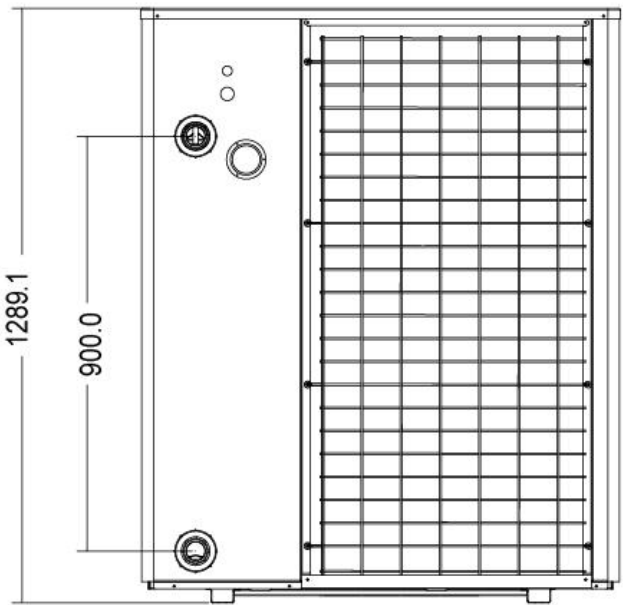
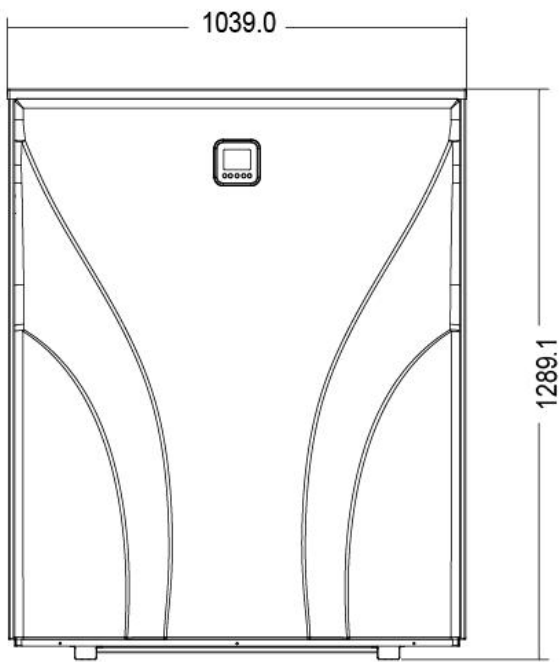

UX30Csi32/UX30Csi32T/UX35Csi32T

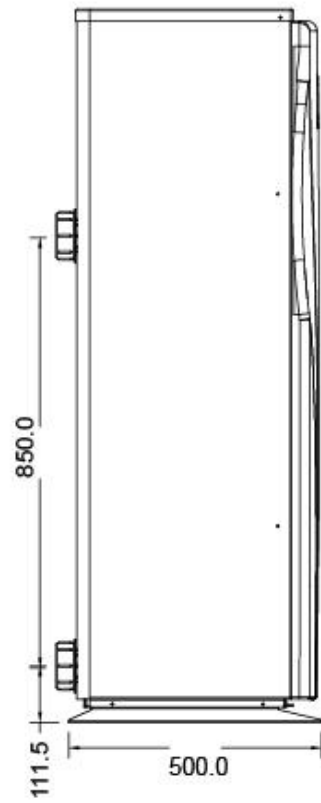
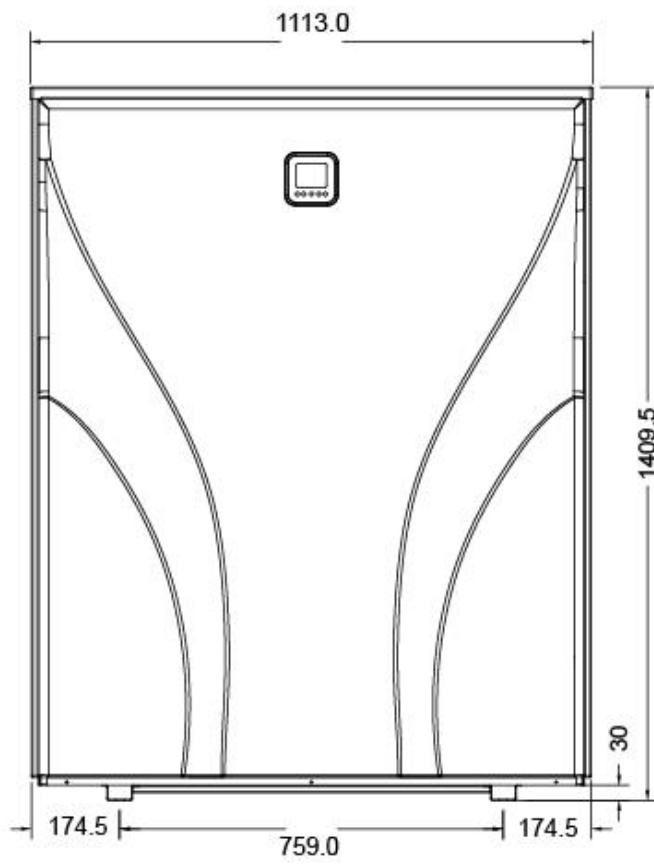

Unit: mm



### 3. Installation et connexion

#### 3.1 Installation d'accessoires



##### **Patin caoutchouc anti-vibration**

1. Prenez les patins caoutchoucs
2. Déposez-les un par un sous les pieds de la machine.

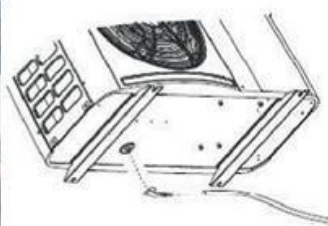

##### **Jet de vidange**

1. Installez le jet de vidange sous le panneau inférieur
2. Connectez-vous avec un tuyau d'eau pour évacuer l'eau.

Remarque: Soulevez la pompe à chaleur pour installer le jet. Ne renversez jamais la pompe à chaleur, cela pourrait endommager le compresseur.



##### **Connecteurs d'admission et de sortie d'eau**

1. Utilisez du ruban téflon pour installer les connecteurs d'admission et de sortie d'eau dans la pompe à chaleur.
2. Installez les raccords comme la photo montre
3. Vissez sur l'entrée et la sortie d'eau



##### **Câblage du câble secteur**

1. Ouvrez le couvercle du boîtier électrique à l'intérieur de la machine
2. Branchez les câbles dans la bonne borne conformément au schéma électrique.

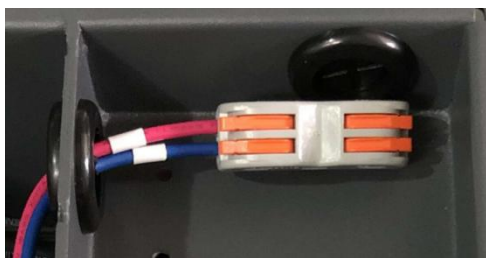

### Câblage de la pompe de filtration (contact sec)

1. Ouvrez le capot supérieur de la pompe à chaleur.
2. Branchez le câble sur le bornier.

### Connexion pour piloter la pompe de filtration

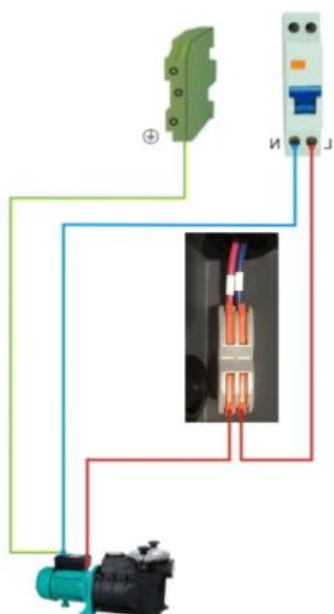
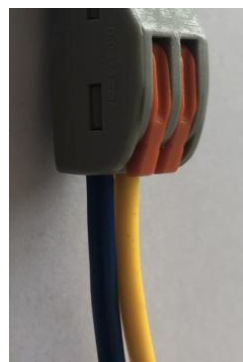
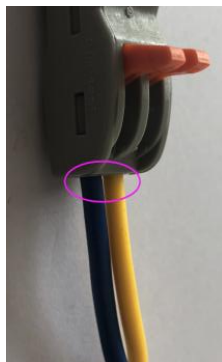
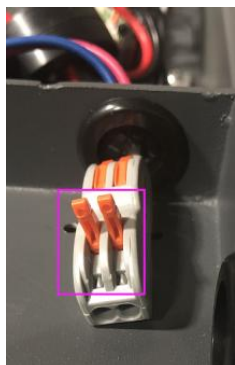

### Notes

Seule la pompe à chaleur est fournie, tous les autres éléments, y compris le by-pass, doivent être fournis par l'utilisateur ou l'installateur.

### Attention :

Avant l'installation lisez attentivement la notice et prenez connaissance des indications ci-dessous :

1. Tous les systèmes de traitement, doivent être installés **en aval** de la pompe à chaleur piscine.
2. Installez un by-pass dans la plupart des installations le débit de la pompe de filtration est supérieur au flux d'eau supportable par l'échangeur de chaleur de la pompe à chaleur.
3. Toujours installer la pompe à chaleur sur une embase solide et utilisez les patins en caoutchouc fournis pour éviter la vibration et les nuisances.

5. Si la machine a été inclinée pendant le transport, il faut attendre au moins 24 heures avant de la démarrer.

### 3.2 Location de la pompe à chaleur piscine

L'appareil peut être installé presque n'importe où à l'extérieur, à condition que les trois facteurs soient satisfaits :

#### 1. Une bonne ventilation - 2. Une alimentation électrique stable et fiable - 3. Un système d'eau recyclée

L'unité peut être installée en pratique n'importe quel endroit à l'extérieur à condition que les distances minimales montrées dans le schéma (ci-dessous) soient conformes. L'installation dans un endroit venteux ne pose pas de problème, sauf si un chauffage au gaz se trouve à proximité (risque des flammes).

**ATTENTION** : L'unité ne doit pas être installée dans une zone où la ventilation d'air est limitée ou l'emplacement qui ne peut fournir de façon continue de l'air, s'assurer que l'entrée d'air ne puisse jamais être obstruée. Les feuilles et autres débris peuvent se coller sur l'évaporateur, ce qui réduit son efficacité et affectera sa durée de vie.

L'illustration ci-dessous montre la distance minimale requise de chaque côté de la pompe à chaleur de piscine.

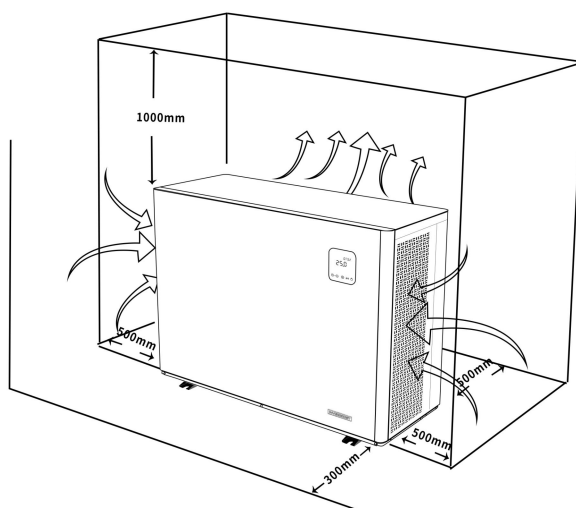

### 3.3 Distance de la piscine

La pompe à chaleur est normalement installée dans un périmètre s'étendant à 7,5 m de la piscine. Plus la distance avec la piscine est grande, plus les pertes de chaleur dans les tuyaux sont importantes. Comme les tuyaux sont principalement souterrains, la perte de chaleur est faible sur des distances allant jusqu'à 30 m (15 m de et vers la pompe; 30 m au total), sauf si le sol est humide ou le niveau des eaux souterraines est élevé. Une estimation approximative de la perte de chaleur par 30 m est de 0,6 kWh (2 000 BTU) pour chaque différence de 5 °C entre la température de l'eau dans la piscine et la température du sol entourant le tuyau. Cela augmente le temps de fonctionnement de 3% à 5%.

### 3.4 Installation du clapet d'anti-retour

Note : Si l'équipement de dosage automatique pour le chlore et l'acidité (pH) est utilisé, il est essentiel de protéger la

pompe à chaleur contre les produits chimiques à concentration trop élevée qui pourraient corroder l'échangeur thermique. Pour cette raison, ce type d'équipement doit être installé **en aval** de la pompe à chaleur. Il est recommandé d'installer un clapet anti-retour pour empêcher un écoulement inverse en l'absence de circulation d'eau. Les dommages induits par non-respects des instructions ne sont pas couverts par la garantie.

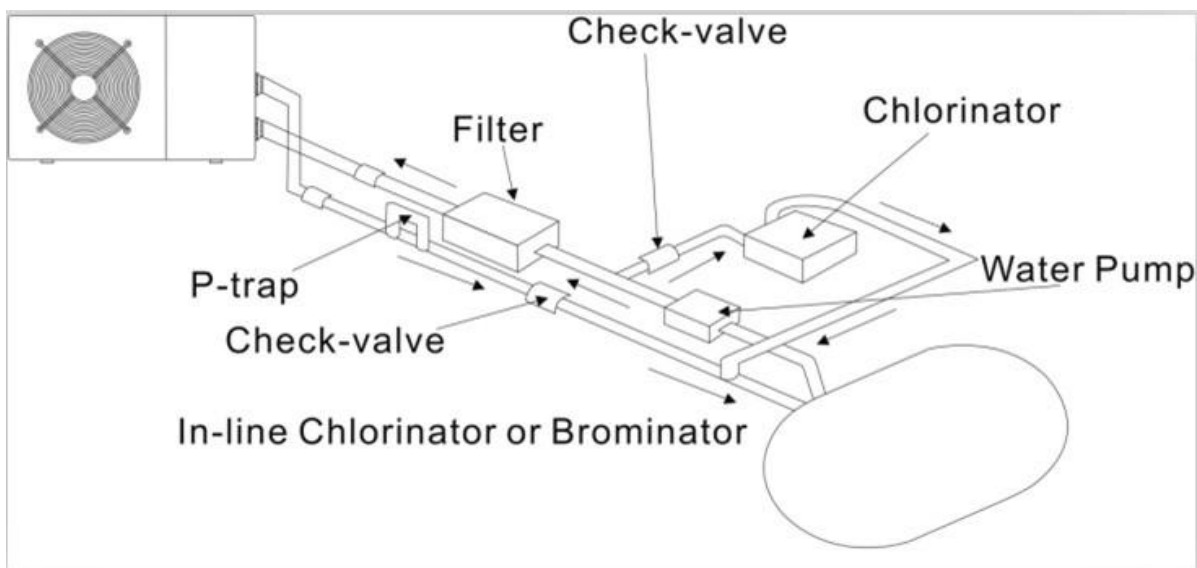

### 3.5 Illustration d'installation

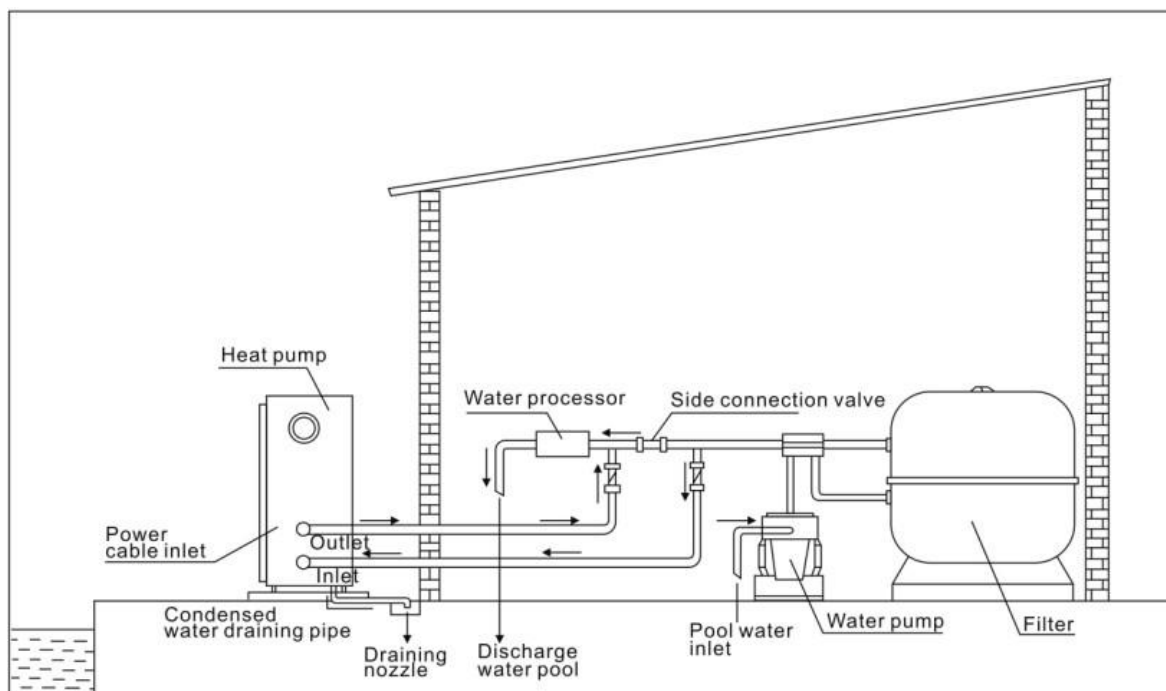

**Note :** Cet schema est seulement un exemple illustratif.

### 3.6 Mise en service initiale de l'unité

**Note : Assurez-vous que la pompe de filtration fonctionne.**

**Une fois toutes les connexions réalisées, veuillez suivre ces étapes :**

- (1) Allumez votre pompe de filtration, vérifiez les fuites d'eau et le débit de la piscine
- (2) Activez l'alimentation électrique de l'appareil, puis appuyez sur la touche ON / OFF du contrôleur, attendez quelques secondes.
- (3) Après un fonctionnement de quelques minutes, assurez-vous que l'air ventilé est froid.
- (4) Lorsque vous arrêtez la filtration, l'unité doit s'arrêter automatiquement, sinon, veuillez vérifier le détecteur de débit.
- (5) Laissez l'unité et la pompe de piscine fonctionner 24 heures par jour jusqu'à ce que l'eau atteigne la température souhaitée. À l'atteinte de la température de consigne choisie, la pompe à chaleur s'arrête, lorsque la température de la piscine descend de plus de 2°C, la pompe à chaleur redémarre (si la filtration est active).

En fonction de la température initiale de l'eau dans la piscine et la température de l'air, il faudra plusieurs jours pour chauffer l'eau à la température souhaitée.

Une bonne couverture de piscine réduit considérablement la durée requise.

### 3.7 Condensation

L'air aspiré dans la pompe à chaleur est fortement refroidi par le fonctionnement de la pompe à chaleur pour chauffer l'eau de la piscine, ce qui provoque de la condensation sur les ailettes de l'évaporateur. Le taux de condensation peut être d'autant plus élevé que l'humidité relative est importante. Ceci est parfois considéré à tort comme une fuite d'eau.

## 4. Regolazione del bypass

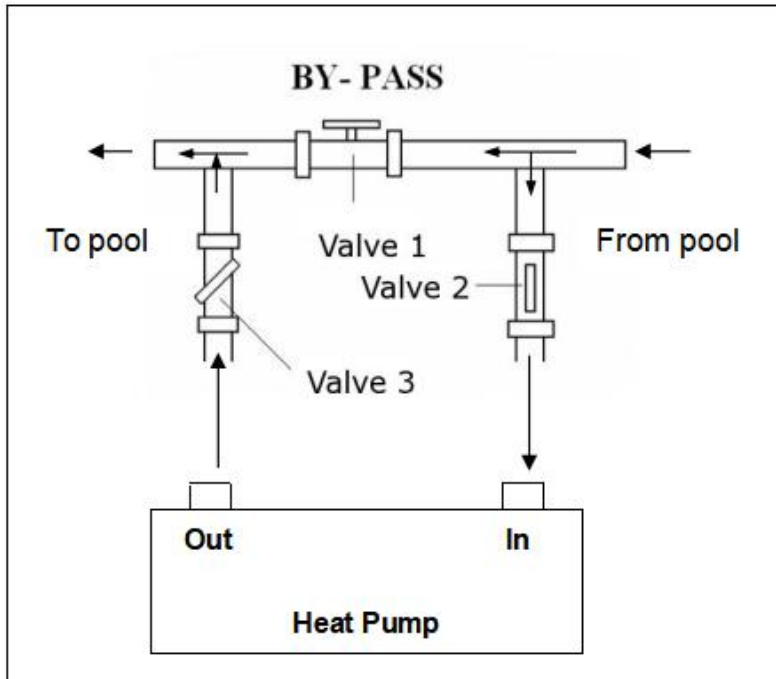

**Utilisez la procédure suivante pour ajuster le by-pass :**

1. Vanne 1 grande ouverte.
2. La vanne 2 et 3 sont fermées.
3. Ouvrez lentement la vanne 2 et la vanne 3 de moitié, puis fermez lentement la vanne 1 pour augmenter le débit d'eau vers la pompe à chaleur
4. Si l'affichage indique 'ON' ou 'EE3', cela signifie que le débit d'eau dans la pompe à chaleur n'est pas suffisant.

### **Comment ajuster le débit d'eau optimal :**

Ajuster la vanne 1 et vérifier la température d'entrée et de sortie d'eau, le débit est optimal lorsque la différence est autour de 2 degrés.

### **Commutateur de débit d'eau :**

L'unité est équipée d'un détecteur de débit pour assurer un fonctionnement avec un débit d'eau suffisant. Il s'active lorsque la pompe de la piscine fonctionne et il s'éteint lorsqu'elle s'arrête.

### **Temporisation :**

L'unité est équipée d'une protection de redémarrage temporisée de 3 minutes. La temporisation est une partie intégrante du circuit de commande, il permet d'éliminer les cycles démarrage court.

La fonction de temporisation interdit pendant 3 minutes tous redémarrage après chaque interruption du circuit de commande. Même une brève interruption de courant active la temporisation pendant 3 minutes et empêche que l'appareil soit redémarré jusqu'à ce que le compte à rebours de 3 minutes soit terminé.

## 5. Fonctionnement du contrôleur

### 5.1. Les fonctions du tableau de commande





A la mise sous tension de la machine, l'écran affiche pendant 3 secondes le code qui indique le modèle de la pompe à chaleur.

### 5.2 Démarrer ou arrêter la pompe à chaleur

#### 5.2.1 Touche



Appuyez sur  pour démarrer la pompe à chaleur, l'écran affichera la température d'eau demandée pendant 5 secondes, ensuite affichage de la température d'arrivée d'eau et le mode de fonctionnement.

Appuyez sur  pour arrêter la pompe à chaleur, l'unité s'arrête et l'écran affiche « OFF »

Attention : Après toute mise à jour, appuyez sur  pour sauvegarder la consigne et sortir du Mode réglage.

Appuyez sur  pour arrêter / démarrer la pompe à chaleur.

#### 5.2.2 Touche



Appuyez sur  pour changer le mode de fonctionnement, Turbo, Smart et silent. Le mode par défaut est le mode Smart.

Si vous choisissez le Turbo, le mot "Turbo" s'allumera, la pompe à chaleur fonctionnera uniquement à pleine puissance.

Choisissez le Smart, le mot "Smart" s'allumera, la pompe à chaleur fonctionnera en "Moyenne et pleine puissance".

Choisissez Silent, le mot "Silent" s'allumera, la pompe à chaleur fonctionnera en "Moyenne et Petite puissance".



#### 5.2.3 Touches



et



**Déverrouillez la commande :**



Appuyez sur  et  pendant 5 secondes pour débloquer la commande.

**L'écran se verrouille automatiquement après 30 s de veille. (lorsque l'écran est verrouillé, l'icône "clé" est allumée)**

### Réglage de la température de l'eau :

Appuyez sur  et  pour sélectionner la température souhaitée.

Plage de réglage du mode de chauffage et du mode automatique: 6-41 °C

Plage de réglage du mode de refroidissement: 6-35 °C

### 5.2.4 Touche

Il existe 3 modes de fonctionnement, chauffage , mode automatique (basculement du mode chaud vers froid et vice versa en automatique) , refroidissement  seul. Vous pouvez changer le mode de fonctionnement en appuyant sur  pendant 5 secondes, peu importe si l'appareil est allumé ou éteint.

Remarque: lors du dégivrage, le symbole de chauffage clignote.

### Logique de fonctionnement du mode <Auto mode>

Fonctionnement du mode automatique Auto Mode (basculement chaud/froid)

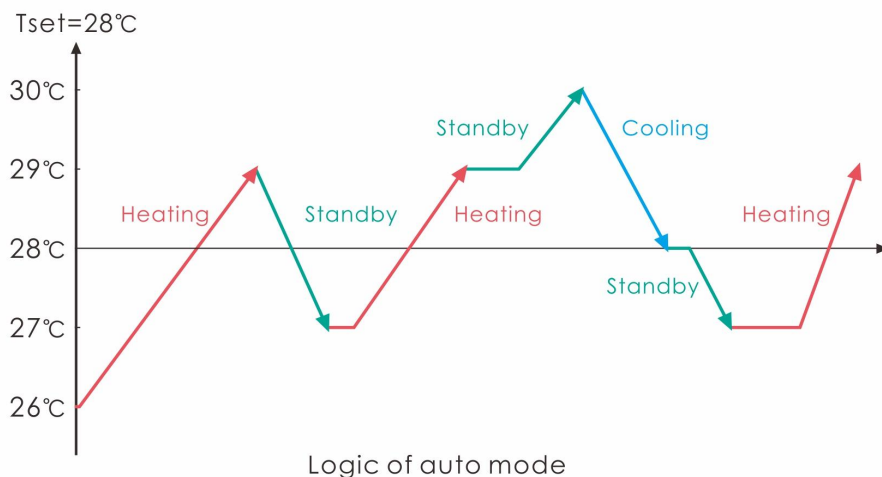

### 5.2.5 Comment vérifier les paramètres.

Appuyez sur  ensuite appuyez sur  afin de vérifier les paramètres (de d0 à d14)

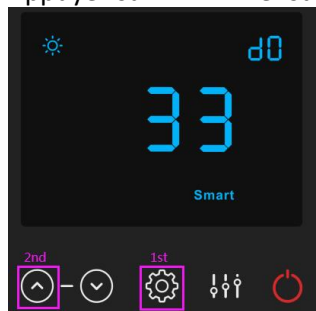



Paramètres	Signification	Amplitude	Remarques
d0	IPM temperature	0-120°C	Valeur test exact par défaut
d1	Température de l'eau d'arrivée	-9°C ~ 99°C	Valeur test exact par défaut
d2	Température de l'eau en sortie	-9°C ~ 99°C	Valeur test exact par défaut
d3	La température ambiante	-30°C ~ 70°C	Valeur test exact par défaut
d4	Limitation de fréquence	0,1,2,4,8,16	Valeur test exact par défaut
d5	Température du circuit	-30°C ~ 70°C	Valeur test exact par défaut
d6	Température d'échappement du gaz	0°C ~ C5°C (125°C)	Valeur test exact par défaut
d7	Position du moteur pas à pas	0~99	N*5
d8	Fréquences de fonctionnement du compresseur	0~99Hz	Valeur test exact par défaut
d9	Intensité du compresseur	0~30A	Valeur test exact par défaut
d10	Intensité du ventilateur	0-1200 (rpm)	Valeur test exact par défaut
d11	Dernières erreurs mémorisées	Erreur en mémoire	



**Remarque :** d4 code de limitation de fréquence,

0 : Aucune limite de fréquence, 1 : Limite de température la bobine,





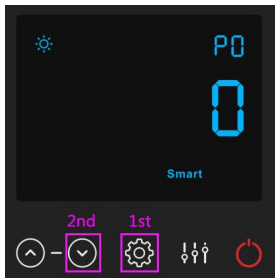

2 : Limite de fréquence de surchauffe ou de sur refroidissement, 4 : Pilotage par la limite de fréquence actuelle,

8 : Pilotage par la limite de fréquence en tension de sortie, 16 : Pilotage par la limite de fréquence de haute température

### 5.2.6 Pour ajuster les paramètres.

Appuyez sur  ensuite appuyez sur  afin de vérifier et ajuster les paramètres (de P0 à P18, voir les illustrations en dessous)









Appuyez pas à pas sur  pour défiler de P0 à P18, quand vous arrivez sur le paramètre souhaitez, alors appuyez sur  pour le sélectionner, un autre appui  vous pouvez le modifier par action sur  ou , pour confirmer la sélection appuyez sur .

Paramètres	Signification	Amplitude	Défaut	Remarques
P0	Dégivrage	0-1	0	Mode 0 mode normal / Mode 1 dégivrage
P1	Mode de fonctionnement	0-1	1	Mode 1 chauffage / Mode 0 refroidissement
P2	Activation de l'horloge	0-1	0	Mode 1 l'horloge est activée, mode 0 l'horloge est hors fonction (les paramètres P5 à P6 pas actifs)
P3	Pilotage de la pompe filtration	0-1	0	Mode 1 toujours en fonctionnement, Mode 0 dépend du fonctionnement du compresseur
P4	Horaire	HH:MM	00: 00	<u>0-23:0-59</u>
P5	Heure démarrage	HH:MM	00: 00	<u>0-23:0-59</u>
P6	Heure d'arrêt	HH:MM	00: 00	<u>0-23:0-59</u>
P7	Calibrage de la température d'eau	-9~9	0	Par défaut : 0
P14	Revenir aux paramètres d'usines	0-1	0	1-Revenir aux paramètres d'usines, 0- Défaut (Revenir aux paramètres d'usines pour P0, P1, P2, P3, P5, P6, P7, P8, P9, 10, P11)
P16	Code produit	/	/	Dépend de la machine
P18	Mode	0-1	0	1—Heating only, 0—Heating/Cooling/Auto mode

Remarque:

- 1). Appuyez longuement sur  pendant 20 s pour régler P14, P16, P18.
- 2). Le paramètre P8, P9, P10, P11, P19, P20 est uniquement pour le réglage d'usine.

### 5.2.7 Retour au paramètres d'usines

Appuyez sur  ensuite sur  pour le sélectionner P14, appuyez longuement sur  pendant 20s, le paramètre clignotera. Appuyez sur  ou  pour choisir 1, puis appuyez sur  pour enregistrer.

### 5.2.8 Mode arrêt automatique et démarrage automatique

Symbole du mode de démarrage et d'arrêt automatique, la lumière sera allumée lorsque la valeur de P2 est sur 1, ce qui signifie que la fonction de programmation de l'horloge de démarrage et d'arrêt est en fonction. Réglez ensuite les heures (paramètre P4), Heure de démarrage (paramètre P5) et Heure d'arrêt (paramètre P6). Tous les symboles (sauf le symbole ) sur l'affichage seront éteints lorsque TIMER est OFF.

Remarque: le symbole  reste allumé lors du redémarrage de la pompe à chaleur, sauf si la valeur de P2 est réglée sur 0.

### 5.2.9 Priorité chauffage se référer (paragraphe 6.9), option de fonctionnement

#### Option 1 ; P3=0 La pompe de filtration démarre et s'arrête en fonction de la pompe à chaleur.

La pompe de filtration démarre 60 secondes avant le compresseur, la pompe de filtration démarre 30 secondes et actionne le détecteur de débit d'eau. Lorsque la pompe à chaleur passe en mode veille, la pompe de filtration s'arrête 5 minutes après l'arrêt du compresseur.

	Etat	Exemple	Logique de pilotage de la filtration	
Mode de chauffage	P3=0, T1≥Tset-0.5 °C, pendant une durée de 30 minutes	P3=0, T1≥27.5°C, pendant une durée 30 minutes	3. La pompe de filtration entrera en mode veille et ne redémarrera pas avant 1 heure, sauf coupure de l'alimentation et redémarrage.	4. Une heure après, la filtration démarre à nouveau pour 5 minutes. Si T1≤27°C, la pompe à chaleur fonctionne jusqu'à T1≥27.5°C et s'arrête alors pour une durée de 30 minutes.
Mode de refroidissement	P3=0, T1≤Tset+0.5 °C, pendant une durée de 30 minutes	P3=0, T1≤28.5°C, pendant une durée de 30 minutes	3. La pompe de filtration entrera en mode veille et ne redémarrera pas avant 1 heure, sauf coupure de l'alimentation et redémarrage.	4. Une heure après, la filtration démarre à nouveau pour 5 minutes. Si T1≥29°C, la pompe à chaleur fonctionne jusqu'à T1≤28.5°C et s'arrête alors pour une durée de 30 minutes.

#### Option 2 ; P3=1 la filtration est toujours active, P2=0 l'horloge non active

Avec la condition P3=1, quand T1≥Tset+1°C est atteint pendant 3 minutes, la pompe à chaleur s'arrête et la filtration continue d'être activé.

**Sous l'option 2, avec activation de l'horloge ; P2=1 nous allons démarrer et arrêter la pompe de filtration en fonction de la programmation de P4 (horloge), P5 (heure de démarrage), P6 (heure d'arrêt)**

#### Condition pour que la pompe à chaleur démarre, horloge ON active ;

Si la température de l'eau est ≤ Tset, quand l'horloge atteint l'heure de démarrage, la pompe de filtration démarre 5 minutes avant la pompe à chaleur, elle reste à l'arrêt si la température de l'eau est ≥ Tset.

#### Condition pour que la pompe à chaleur s'arrête, horloge OFF active ;

Quand la température de l'eau est ≥ Tset, avant que l'horloge soit atteint son heure d'arrêt, la pompe à chaleur s'arrête est la pompe de filtration reste active jusqu'à l'atteinte de l'heure d'arrêt.

Si la température de l'eau est ≤ Tset, quand l'horloge atteint l'heure d'arrêt, la pompe à chaleur s'arrête et 5 minutes après la pompe de filtration s'arrête.

#### REMARQUE :

Tset = régler la température de l'eau, par exemple : Tset = 28°C température de l'eau souhaitez de la piscine

Tset - 0.5 = moins de 0.5°C de la température de consigne, Tset -0.5 = 28-0.5 = 27.5°C

Tset + 0.5 = plus de 0.5°C de la température de consigne, Tset + 0.5 = 28+0.5=28.5°C

### 5.3 Logique en mode chauffage

Statut de travail		Mode travail	Température de l'eau -T1	Exemple, L'eau en température -T1	Niveau de travail pompe à chaleur
1		Lorsque vous sélectionnez le "mode Smart "	$T1 < T_{set}-1$	$T1 < 27^{\circ}\text{C}$	Mode Powerful -fréquence F9
2			$T_{set}-1 \cong T1 < T_{set}$	$27^{\circ}\text{C} \cong T1 < 28^{\circ}\text{C}$	Fréquence: F9 -F8-F7,...,-F2
3			$T_{set} \cong T1 < T_{set}+1$	$28^{\circ}\text{C} \cong T1 < 29^{\circ}\text{C}$	Mode Silent-fréquence F2
4			$T1 \cong T_{set}+1$	$T1 \cong 29^{\circ}\text{C}$	La pompe à chaleur sera en veille et cessera de fonctionner jusqu'à ce que l'eau atteigne une température inférieure à $28^{\circ}\text{C}$ .
5	Mise en route de la pompe à chaleur	Lorsque vous sélectionnez le "mode Silent"	$T1 < T_{set}$	$T1 < 28^{\circ}\text{C}$	Mode Smart -fréquence F5.
6			$T_{set} \cong T1 < T_{set}+1$	$28^{\circ}\text{C} \cong T1 < 29^{\circ}\text{C}$	Mode Silent-fréquence F2/F1.
7			$T1 \cong T_{set}+1$	$T1 \cong 29^{\circ}\text{C}$	La pompe à chaleur sera en veille et cessera de fonctionner jusqu'à ce que l'eau atteigne une température inférieure à $28^{\circ}\text{C}$ .
8			$T1 < T_{set}+1$	$T1 < 29^{\circ}\text{C}$	Mode Powerful-fréquence F10/F9
9		Lorsque vous sélectionnez le "mode Powerful"	$T1 \cong T_{set}+1$	$T1 \cong 29^{\circ}\text{C}$	La pompe à chaleur sera en veille et cessera de fonctionner jusqu'à ce que l'eau atteigne une température inférieure à $28^{\circ}\text{C}$ .
10	Redémarrage pour chauffer de l'eau après le mode veille	Lorsque la pompe à chaleur fonctionne en "mode Smart"	$T1 \cong T_{set}$	$T1 \cong 28^{\circ}\text{C}$	Prêt à fonctionner
11			$T_{set} > T1 \cong T_{set}-1$	$28^{\circ}\text{C} > T1 \cong 27^{\circ}\text{C}$	Silent-fréquence F2
12			$T_{set}-1 > T1 \cong T_{set}-2$	$27^{\circ}\text{C} > T1 \cong 26^{\circ}\text{C}$	Fréquence : F2 -F3-F4,...,-F9
13		$< T_{set}-2$	$< 26^{\circ}\text{C}$	Powerful-fréquence F9	
14		Lorsque la pompe à chaleur fonctionne en "mode Silent"	$\cong T_{set}$	$\cong 28^{\circ}\text{C}$	Prêt à fonctionner
15		$T_{set} > T1 \cong T_{set}-1$	$28^{\circ}\text{C} > T1 \cong 27^{\circ}\text{C}$	Silent mode-fréquence F2/F1	
16		$T1 < T_{set}-1$	$T1 < 27^{\circ}\text{C}$	Smart -fréquence F5	
17		Lorsque la pompe à chaleur fonctionne en "mode Powerful"	$T1 < T_{set}-1$	$T1 < 27^{\circ}\text{C}$	Powerful -fréquence F10/F9

## 5.4 Logique en mode refroidissement

Statut de travail		Mode travail	L'eau en température-T1	Par exemple, L'eau en température-T1	Niveau de travail pompe à chaleur
1	Mise en route de la pompe à chaleur	Lorsque vous sélectionnez le "mode Smart "	$T1 \leq Tset-1$	$T1 \leq 27^{\circ}C$	Etre prêt
2			$Tset-1 < T1 \leq Tset$	$27^{\circ}C < T1 \leq 28^{\circ}C$	Mode Silent-fréquence F2
3			$Tset < T1 \leq Tset+1$	$28 < T1 \leq 29^{\circ}C$	Fréquence: F9 -F8-F7,...,- F2
4			$T1 \geq Tset+1$	$T1 \geq 29^{\circ}C$	Mode Powerful-F9
5		Lorsque vous sélectionnez le "mode Silent"	$T1 \leq Tset-1$	$\leq 27^{\circ}C$	Etre prêt
6			$Tset-1 < T1 \leq Tset$	$27^{\circ}C < T1 \leq 28^{\circ}C$	Mode Silent - fréquence F2/F1
7			$T1 > Tset$	$T1 > 28^{\circ}C$	Mode Smart -fréquence F5
8		Lorsque vous sélectionnez le "mode Powerful"	$T1 > Tset-1$	$T1 > 27^{\circ}C$	Mode Powerful-fréquence F10/F9
9			$T1 \leq Tset-1$	$T1 \leq 27^{\circ}C$	Prêt à fonctionner
10	Redémarrage pour refroidir de l'eau après le mode veille	Smart	$T1 \leq Tset-1$	$T1 \leq 27^{\circ}C$	Prêt à fonctionner
11			$Tset \leq T1 < Tset+1$	$28 \leq T1 < 29^{\circ}C$	Silent- fréquence F2
12			$Tset+1 \leq T1 < Tset+2$	$29 \leq T1 < 30^{\circ}C$	Fréquence : F2 -F3-F4,...,- F9
13			$T1 \geq Tset+2$	$T1 \geq 30^{\circ}C$	Mode Powerful-fréquence F9
14		Silent	$Tset < T1 \leq Tset+1$	$28 < T1 \leq 29^{\circ}C$	Mode Silent-fréquence F2/F1
15			$T1 > Tset+1$	$T1 > 29^{\circ}C$	Mode Smart-fréquence F5
16		Powerful	$T1 > Tset+1$	$T1 > 29^{\circ}C$	Mode Powerful-fréquence F10/F9
17	$T1 \leq Tset-1$		$T1 \leq 27^{\circ}C$	Prêt à fonctionner	

## 6. Guide de dépannage

### 6.1 Code d'erreur affichée sur le tableau de commande

Code d'erreur	Dysfonctionnement	Raison	Solutions
EE01	Protection haute pression TS4	1. Température ambiante trop haute	1. Vérifier le by-pass et le débit d'eau
		2. Température de l'eau trop haute	2. Vérifier le ventilateur
		3. Vérifier la vitesse du ventilateur	3. Vérifier le gaz
EE02	Protection basse pression	1. Réfrigérant ne suffit pas	1. Vérifiez s'il y a des fuites de gaz, re remplissez le réfrigérant
		2. Le débit d'eau n'est pas suffisant	2. Nettoyez l'échangeur d'air
		3. Filtre ou vanne électronique bloqué	3. Vérifier la charge en gaz
ON or EE03	Protection débit d'eau	1. Le débit d'eau n'est pas suffisant, filtre ou vanne bloqué	1. Vérifier si le débit est suffisant
		2. Détecteur de débit défaillant	2. Changer le détecteur de débit
EE04	En mode chauffage, défaut surchauffe température (d2-TH5)	1. Le débit d'eau n'est pas suffisant, filtre ou vanne bloqué	1. Vérifier si le débit est suffisant
		2. Détecteur de débit défaillant	2. Changer le détecteur de débit
		3. La valeur du capteur d2-TH5 est anormale	3. Remplacer le capteur d2-TH5
EE05	Protection température d'échappement d6-TH3	1. Réfrigérant ne suffit pas	1. Vérifiez s'il y a des fuites de gaz, re remplissez le réfrigérant
		2. Le débit d'eau n'est pas suffisant	2. Vérifier le By-pass
		3. Filtre ou vanne électronique bloqué	3. Vérifier la charge en gaz
		4. Défaut sonde d6-TH3,	4. Vérifier la sonde d6-TH3
EE06	Défaut contrôleur	1. Le raccordement est défaillant	1. Vérifiez la connexion
		2. Le contrôleur est défaillant	2. Vérifier changer le câble
			3. Arrêt / Marche de la machine
			4. Vérifier changer le contrôleur
EE07	Protection du compresseur	1. Vérifiez la connexion	1. Vérifiez le compresseur
		2. Vérifier le raccordement	2. Vérifier les 3 phases
		3. Accumulation liquide et gaz	3. Les tensions d'alimentation
		4. Compresseur ou carte électronique défaillant	4. Vérifier les phases
		5. débit d'eau anormal	5. Vérifier le débit d'eau
		6. Fluctuation alimentation électrique	6. Vérifier le réseau électrique
EE08	Défaillance de communication entre le contrôleur et la carte de puissance	1. Le raccordement est défaillant	1. Vérifiez la connexion
		2. Le contrôleur est défaillant	2. Vérifier changer le câble
			3. Vérifier changer le contrôleur
EE09	Défaillance de communication entre le contrôleur et la carte de commande	1. Le raccordement est défaillant	1. Vérifiez la connexion
		2. Le contrôleur est défaillant	2. Vérifier changer le câble
EE10	Protection haut	1. Tension trop haute	1. Vérifiez la tension

	voltage	2. Carte puissance défaillant	2. Changer la carte de puissance et/ou de commande
EE11	Défaillance carte mère IPM Module	1. Les données ne sont pas correctes	1. Erreur de programmation, couper l'alimentation électrique et démarrer après 3 minutes
		2. Vérifier le raccordement	2. Changer la carte
		3. Accumulation liquide et gaz	3. Vérifier les séquences
		4. Compresseur ou la carte est défaillante	
EE12	L'alimentation électrique est trop faible	1. La tension d'alimentation n'est pas correcte	1. Vérifier la tension d'alimentation
		2. La carte de puissance est défaillante	2. Changer la carte
EE13	Protection électrique	1. Les données ne sont pas correctes	1. Vérifiez le compresseur
		2. Le débit est anormal	2. Vérifier le circuit d'eau
		3. La tension n'est pas stable	3. Vérifier les tensions d'alimentation
		4. Défaillance de l'inducteur PFC	4. Vérifier
EE14	Module IPM température de fonctionnement anormale	1. La tension d'alimentation n'est pas correcte	1. Vérifiez la carte de puissance
		2. Le moteur du ventilateur est défectueux ou les hélices sont cassées	2. Vérifier la vitesse du ventilateur
			3. Vérifier les hélices
EE15	Protection haute température module IPM	1. La tension d'alimentation n'est pas correcte	1. Vérifiez la carte électronique
		2. Le moteur du ventilateur est défectueux ou les hélices sont cassées	2. Vérifier la vitesse du ventilateur
			3. Vérifier les hélices
EE16	Protection module PFC	1. Les données ne sont pas correctes	1. Vérifiez la carte électronique
		2. Le moteur du ventilateur est défectueux	2. Vérifier la vitesse du ventilateur
		3. Les hélices sont cassées	3. Vérifier les hélices
		4. La tension n'est pas stable	4. Vérifier la tension
EE17	Défaut ventilateur DC	1. Le moteur du ventilateur est défectueux	1. Vérifiez le moteur du ventilateur
		2. La carte électronique est défectueuse	2. Changer la carte électronique
		3. Les hélices sont défectueuses	3. Vérifier les hélices
EE18	Module PFC température de fonctionnement anormale	La carte électronique est défectueuse	1. Changer la carte électronique
			2. Vérifier la vitesse du ventilateur
			3. Vérifier les hélices
EE19	Protection haute température module PFC	1. La tension d'alimentation n'est pas correcte	1. Vérifiez la carte électronique
		2. Le moteur du ventilateur est défectueux	2. Vérifier la vitesse du ventilateur
		3. Les hélices sont cassées	3. Vérifier les hélices
		4. Les raccords sur la carte de puissance ne sont pas serrés	4. Vérifier les raccordements, resserrer les vis
EE20	Défaut puissance d'alimentation	La puissance d'alimentation varie de façon trop importante	Vérifier la tension d'alimentation
EE21	Défaut programme	1. Le compresseur perd des pas, vitesse irrégulière	1. Vérifiez la carte électronique

		2. Défaut programme	2. Recharger le programme
		3. Impureté dans le compresseur	
EE22	Protection haute tension	1. La tension d'alimentation n'est pas correcte	1. Vérifiez la carte électronique
		2. La carte d'alimentation est défectueuse	2. Changer la carte électronique
EE23	Défaut démarrage du compresseur	1. La carte d'alimentation est défectueuse	1. Vérifiez la carte électronique
		2. Vérifier le raccordement	2. Vérifier les raccordements ou changer le compresseur
		3. Accumulation liquide et gaz	
		4. La tension n'est pas stable	
EE24	Température ambiante ou carte électronique	La température ambiante ou la température d'eau arrivée est trop faible	Vérifier et changer la carte électronique
EE25	Défaut alimentation du compresseur	Le compresseur marche sur 1 ou 2 phases	Vérifier le câblage
EE26	Défaut inversion vanne 4 voies	1. blocage inversion vanne 4 voies	1. Basculer du mode chaud / froid pour vérifier l'inversion de la vanne
		2. Manque de gaz (pas de détection d5-TH2 ou d3-TH1)	2. Changer la vanne 4 voies
			3. Vérifier la charge en gaz
EE27	Défaut données mémoire EEPROM	1. Perte des données dans la mémoire	1. Recharger les données dans la mémoire
		2. Défaut carte électronique	2. Changer la carte électronique
EE28	Défaut de communication avec le contrôleur	Défaut sur la carte électronique	1. Arrêt / marche pour redémarrer
			2. Vérifier et changer la carte électronique
PP01	Défaillance du capteur de température d'eau arrivée d1-TH6	1. Raccordement défaillant	1. Connecter correctement
		2. Capteur en court-circuit ou défectueux	2. Vérifiez les valeurs où remplacer le capteur
PP02	Défaillance du capteur de température d'eau sortie d2-TH5	1. Raccordement défaillant	1. Connecter correctement
		2. Capteur en court-circuit ou défectueux	2. Vérifiez les valeurs où remplacer le capteur
PP03	Défaillance du capteur de condenseur de chauffage d5-TH2	1. Raccordement défaillant	1. Connecter correctement
		2. Capteur en court-circuit ou défectueux	2. Vérifiez les valeurs où remplacer le capteur
PP04	Défaillance du capteur de gaz de retour	1. Raccordement défaillant	1. Connecter correctement
		2. Capteur en court-circuit ou défectueux	2. Vérifiez les valeurs où remplacer le capteur
PP05	Défaillance du capteur de température ambiante d3-TH1	1. Raccordement défaillant	1. Connecter correctement
		2. Capteur en court-circuit ou défectueux	2. Vérifiez les valeurs où remplacer le capteur
PP06	Défaillance du capteur de condenseur de refroidissement d6-TH3	1. Raccordement défaillant	1. Connecter correctement
		2. Capteur en court-circuit ou défectueux	2. Vérifiez les valeurs où remplacer le capteur
PP07	Protection antigel du premier niveau	La température ambiante ou la température d'eau arrivée est trop faible	Protection automatique antigel du premier niveau



	en hiver	vérifier d3 et d1	
PP08	Protection de température ambiante trop basse	1. La température ambiante trop faible, vérifier d3	1. Vérifier la température
		2. Capteur en court-circuit ou défaillant d3-TH1	2. Changer le capteur
PP10	Température de refroidissement du condenseur trop haute protection d3-TH2	1. Température ambiante trop haute	1. Vérifier la température
		2. Problème gaz réfrigérant	2. Vérifier le gaz
PP11	Température de l'eau trop froide protection en mode refroidissement d2-TH5	1. Débit d'eau trop faible	1. Vérifier le by-pass et le débit d'eau
		2. Température de la sonde d2-TH5 anormale	2. Vérifier le gaz et la sonde d2-TH5

**Remarques:**

1. En mode chauffage, si la température de sortie d'eau est supérieure à la température réglée de 7°C, le contrôleur affiche EE04 protection contre la surchauffe de l'eau.
2. En mode de refroidissement, si la température de sortie d'eau est inférieure à la température réglée de 7°C, le contrôleur affiche PP11 pour la protection contre le refroidissement excessif de l'eau.

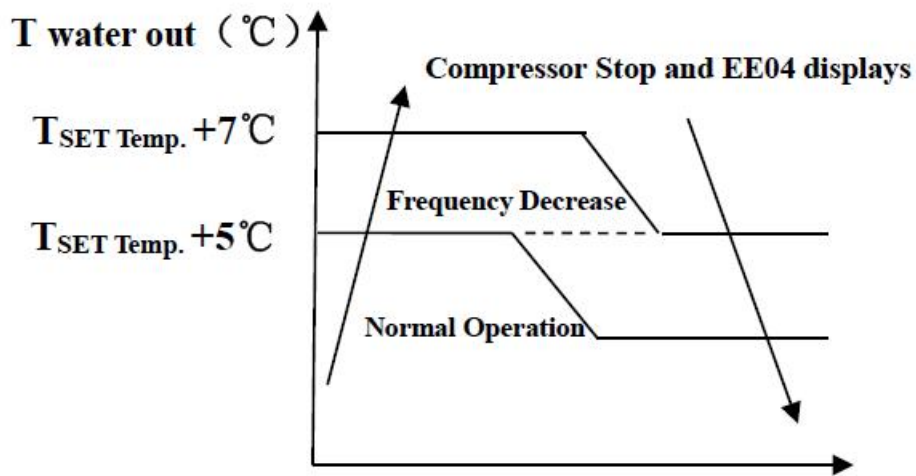

EE04 En mode chauffage, défaut surchauffe température (T2)

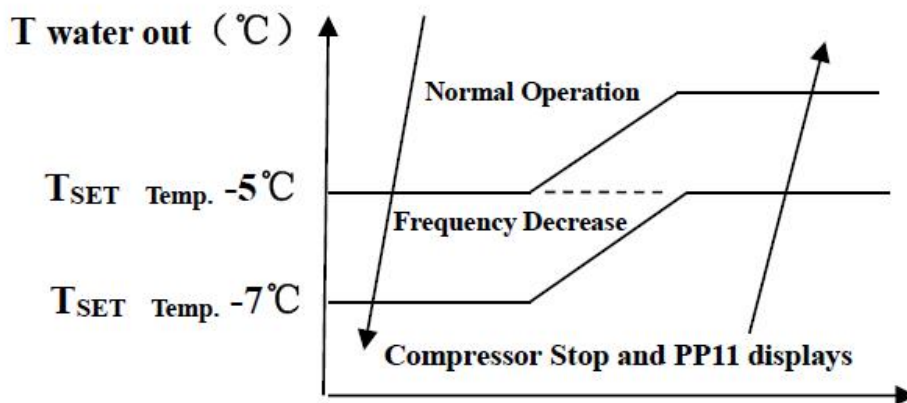

PP11 T2 Température de l'eau trop froide protection en mode refroidissement

## 6.2 Dysfonctionnement sans code d'erreurs affichées sur l'écran

Dysfonctionnements	Observations	Raisons	Solutions
La Pompe à chaleur ne fonctionne pas	Aucun affichage sur le contrôleur à LED	Pas d'alimentation	Vérifiez le disjoncteur du câble et du circuit soit connecté
	Contrôleur à LED affiche l'heure	Pompe à chaleur en état de veille	Démarrez la pompe à chaleur.
	Contrôleur à LED affiche la température réelle de l'eau.	1. Température de l'eau atteint presque la valeur fixée, pompe à chaleur est en état à température constante. 2. Pompe à chaleur commence juste à fonctionner 3. En état de dégivrage	1. Vérifiez le réglage de température de l'eau. 2. Démarrez la pompe à chaleur après quelques minutes. 3. Contrôleur à LED doit afficher "Dégivrage"
La Température de l'eau est refroidie lorsque la pompe à chaleur fonctionne sous le mode de chauffage	Contrôleur à LED affiche la température réelle de l'eau et aucun code d'erreur ne s'affiche	1. Choix du mauvais mode. 2. Les chiffres montrent des défaillances. 3. Défaillance du contrôleur	1. Réglez le mode à la bonne fonction 2. Remplacez le contrôleur à LED en panne, puis vérifiez l'état après avoir changé le mode de fonctionnement, vérifiez la température d'eau d'arrivée et de sortie 3. Remplacez ou réparez l'unité
Fonctionnement court	Contrôleur à LED affiche la température réelle de l'eau, aucun code d'erreur ne s'affiche	1. Ventilateur ne fonctionne pas 2. La ventilation d'air n'est pas suffisante 3. Réfrigérant ne suffit pas.	1. Vérifiez les connexions des câbles entre le moteur et le ventilateur, le cas échéant, il doit être remplacé. 2. Vérifiez l'emplacement de l'unité de pompe à chaleur, et éliminez tous les obstacles pour faire bonne ventilation. 3. Remplacez ou réparez l'unité
Tâches d'eau	Les tâches d'eau sur la pompe à chaleur	1. Protection. 2. Infiltration d'eau.	1. Aucune action (condensat) 2. Vérifiez l'échangeur de chaleur en titane avec soin, s'il y a une fuite
Trop de glace sur l'évaporateur	Trop de glace sur l'évaporateur.		1. Vérifiez l'emplacement de l'unité de pompe à chaleur, et éliminez tous les obstacles 2. Contacter le service technique

# 7. Câblage Electrique

UX11Csi32/UX14Csi32/UX17Csi32/UX21Csi32

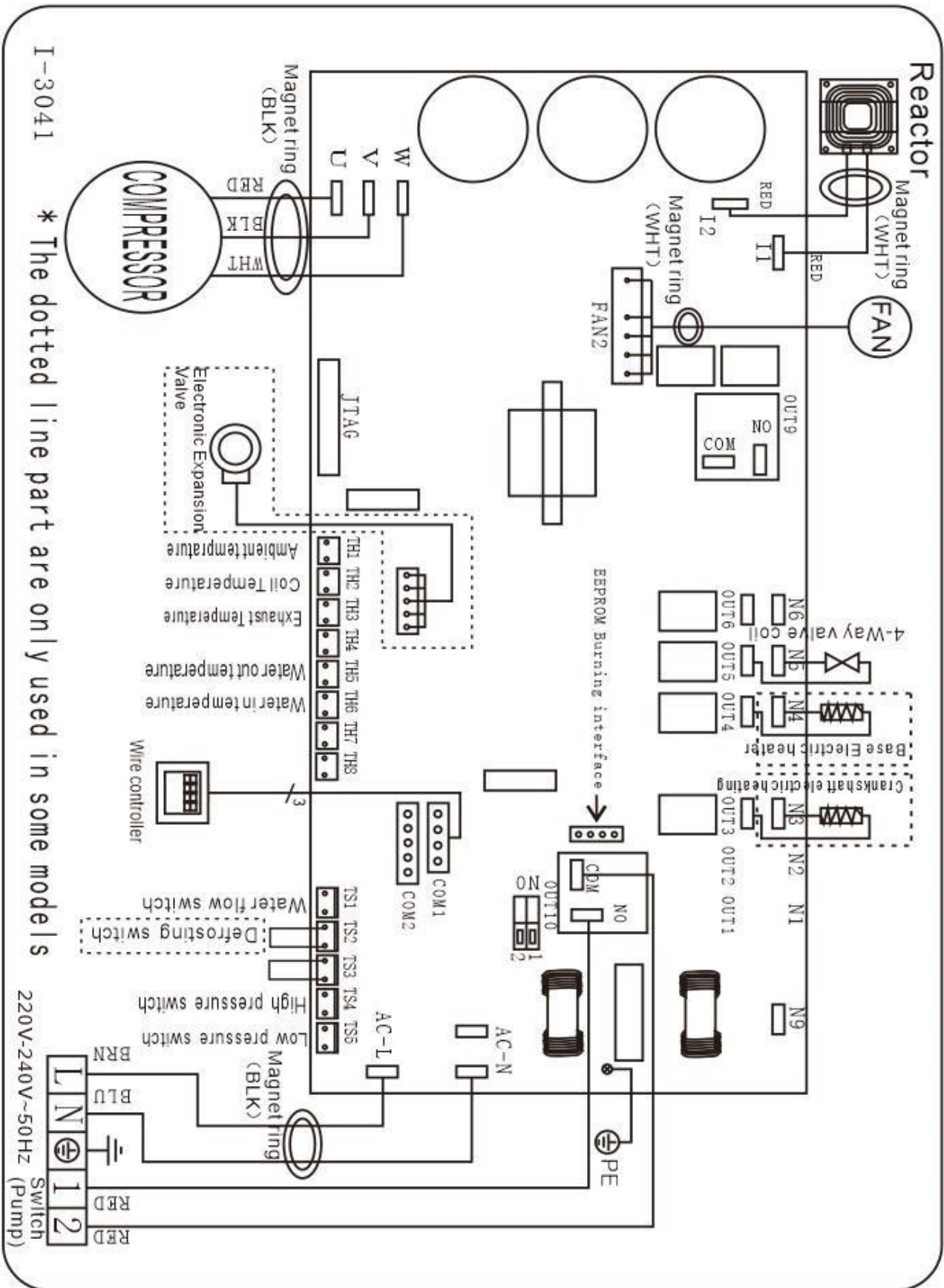

I-3041

\* The dotted line part are only used in some models

I-3051S \* The dotted line part are only used in some models

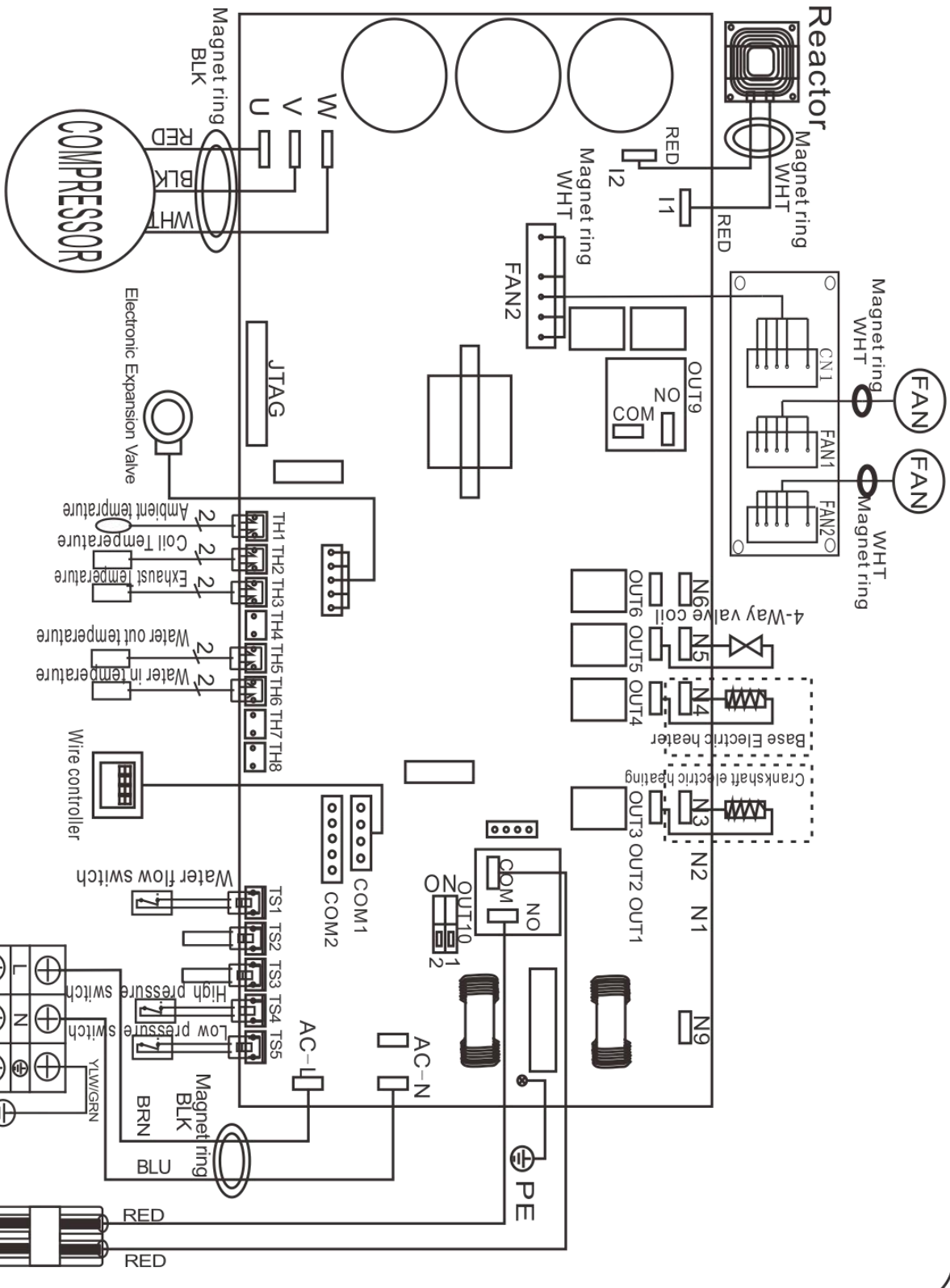

Power Supply  
220V-240V~50Hz

SWITCH  
(Water Pump)



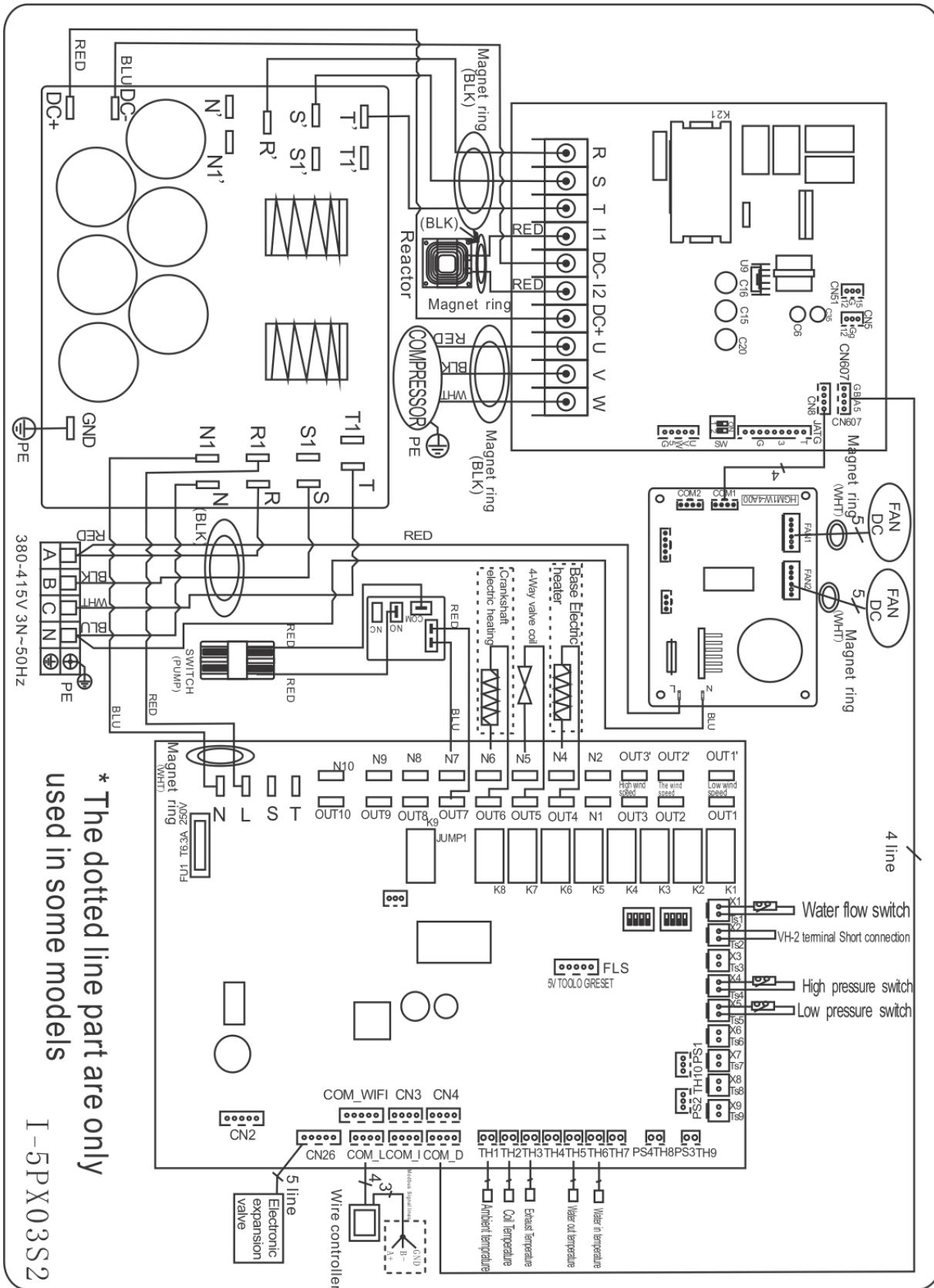

**NOTE :**

- (1) Le schéma de câblage électrique ci-dessus est seulement pour votre référence, veuillez utiliser le schéma de câblage affiché sur la machine.
- (2) La pompe à chaleur de piscine doit être bien raccordée à la terre, bien que l'échangeur de chaleur d'appareil soit

électriquement isolé du reste de l'unité. La mise à la terre de l'unité est toujours nécessaire pour vous protéger contre les courts-circuits à l'intérieur de l'unité.

**Sectionneur** : Un moyen d'interruption (disjoncteur, interrupteur à fusibles) doit être en vue et facilement accessible de l'unité. C'est une pratique courante, il permet la mise hors tension à distance de l'équipement sans surveillance et permet aussi de couper l'alimentation à l'unité alors que l'appareil est en réparation.

## 8. Entretien

(1) Vous devez vérifier régulièrement le système d'alimentation en eau pour éviter que l'air ne pénètre dans le système et ne se produise un faible débit d'eau, car cela réduirait les performances et la fiabilité de l'unité HP.

(2) Nettoyez régulièrement vos piscines et votre système de filtration pour éviter d'endommager l'appareil en raison de la saleté ou du filtre obstrué.

(3) Vous devez évacuer l'eau du bas de la pompe à eau si l'unité HP cesse de fonctionner pendant une longue période (en particulier pendant la saison d'hiver).

(4) D'une autre manière, vous devriez vérifier que l'unité est complètement remplie d'eau avant de recommencer à fonctionner.

(5) Une fois l'unité conditionnée pour la saison d'hiver, il est recommandé de couvrir la pompe à chaleur avec une pompe à chaleur spéciale hiver.

(6) Lorsque l'unité est en marche, il y a tout le temps une petite décharge d'eau sous l'unité.



# 9. Schéma éclaté et entretien

UX11Csi32/UX14Csi32

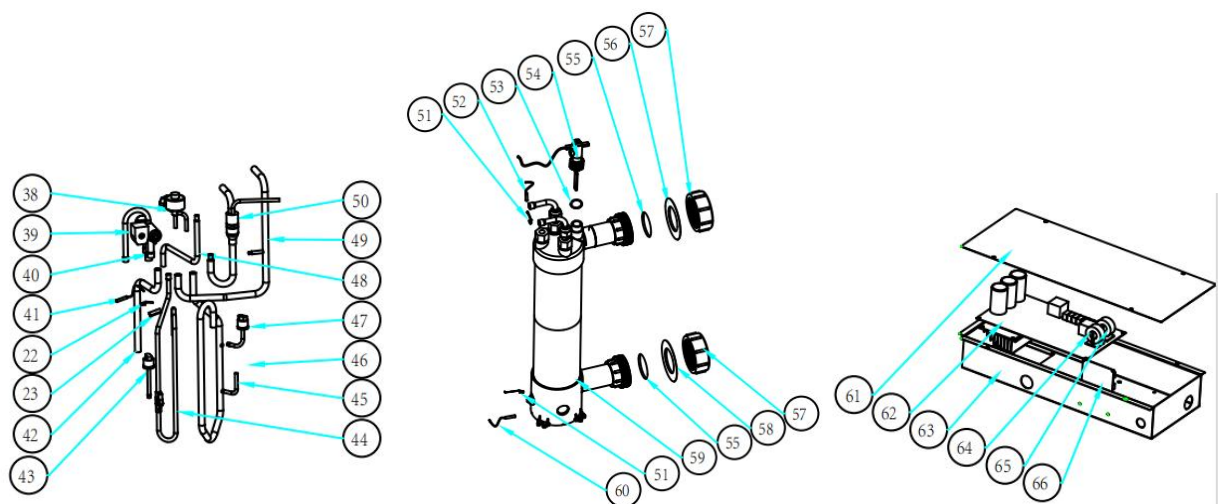
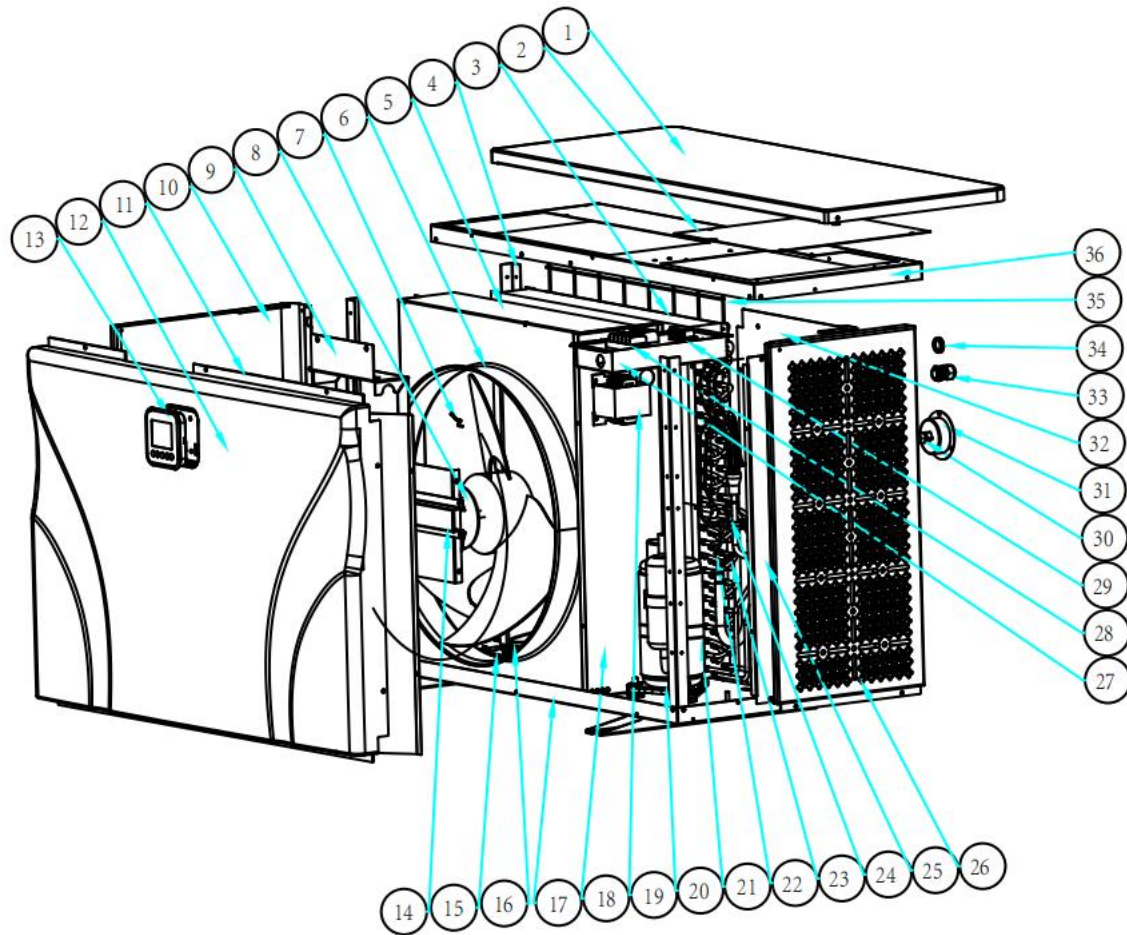

**UX11Csi32**

NO.	ERP	Part name	NO.	ERP	Part name
1	109060056	Le couvercle supérieur	34	136020119	Trou de passage de câble
2	109060053	Panneau de service	35	109060017	Grille arrière
3	103000335	Évaporateur	36	109060051	Cadre supérieur
4	109060052	Pilier	37	119000058	EEV
5	109060023	Panneau de ventilateur	38	121000037	Bobine de vanne 4 voies
6	117110063	Temp. Ambiante capteur	39	121000034	Vanne à quatre voies
7	132000015	Pale de ventilateur	40	117110050	Capteur de température de l'évaporateur
8	112000031	Moteur de ventilateur	41	113060188	Tube
9	109060027	Support de moteur de ventilateur	42	116000066	Pressostat haute pression
10	109060058	panneau de gauche	43	113020623	Tube
11	109060042	Panneau de service	44	113020579	Tube
12	133470001	Panneau avant	45	/	Tube
13	117020293	Contrôleur	46	116000071	Pressostat basse pression
14	109060054	Pilier	47	113080123	Tube
15	109060004	Support d'évaporateur	48	113030214	Tube
16	142000142	Résistance de chauffage de l'évaporateur	49	113070067	Tube
17	109060050	Plateau de base	50	108010025	Agrafe
18	109060059	Panneau d'isolement	51	117110057	Temp. Sortie eau capteur
19	117230003	Réacteur	52	136010072	Anneau en caoutchouc sur le raccordement à l'eau
20	101000188	Compresseur	53	116000103	Interrupteur de débit d'eau
21	142000072	Résistance de chauffage du compresseur	54	133020007	Couverture en PVC
22	113190007	Agrafe	55	133020012	Anneau en caoutchouc sur le raccordement à l'eau
23	113190001	Support de capteur	56	102050004	Kits de raccordement à l'eau
24	117110061	Temp de décharge. capteur	57	133020012	Anneau en caoutchouc sur le raccordement à l'eau
25	109060044	Panneau de service	58	102041113	Échangeur de chaleur en titane
26	109060057	Panneau droit	59	117110053	Temp entrée d'eau. capteur
27	108960058	Boîtier de câblage	60	109060007	Couvercle de boîte électrique
28	115000004	Bornier à 3 voies	61	117100079	PCB
29	136010004	Agrafe	62	109060039	Boîte électrique
30	124020011	Vite	63	117240002	Bague aimantée
31	106000012	Manomètre haute pression	64	117240003	Bague aimantée
32	109060055	Panneau arrière	65	117010122	Module WIFI
33	110000039	Connecteur de fil			

**UX14Csi32**

NO.	ERP	Part name	NO.	ERP	Part name
1	109060056	Le couvercle supérieur	34	136020119	Trou de passage de câble
2	109060053	Panneau de service	35	109060017	Grille arrière
3	103000335	Évaporateur	36	109060051	Cadre supérieur
4	109060052	Pilier	37	119000058	EEV
5	109060023	Panneau de ventilateur	38	121000037	Bobine de vanne 4 voies
6	117110063	Temp. Ambiante capteur	39	121000034	Vanne à quatre voies
7	132000015	Pale de ventilateur	40	117110050	Capteur de température de l'évaporateur
8	112000031	Moteur de ventilateur	41	113060188	Tube
9	109060027	Support de moteur de ventilateur	42	116000066	Pressostat haute pression
10	109060058	panneau de gauche	43	113020623	Tube
11	109060042	Panneau de service	44	113020693	Tube
12	133470001	Panneau avant	45	/	Tube
13	117020293	Contrôleur	46	116000071	Pressostat basse pression
14	109060054	Pilier	47	113080123	Tube
15	109060004	Support d'évaporateur	48	113030214	Tube
16	142000142	Résistance de chauffage de l'évaporateur	49	113070067	Tube
17	109060050	Plateau de base	50	108010025	Agrafe
18	109060059	Panneau d'isolement	51	117110057	Temp. Sortie eau capteur
19	117230003	Réacteur	52	136010072	Anneau en caoutchouc sur le raccordement à l'eau
20	101000188	Compresseur	53	116000103	Interrupteur de débit d'eau
21	142000072	Résistance de chauffage du compresseur	54	133020007	Couverture en PVC
22	113190007	Agrafe	55	133020012	Anneau en caoutchouc sur le raccordement à l'eau
23	113190001	Support de capteur	56	102050004	Kits de raccordement à l'eau
24	117110061	Temp de décharge. capteur	57	133020012	Anneau en caoutchouc sur le raccordement à l'eau
25	109060044	Panneau de service	58	102041138	Échangeur de chaleur en titane
26	109060057	Panneau droit	59	117110053	Temp entrée d'eau. capteur
27	108960058	Boîtier de câblage	60	109060007	Couvercle de boîte électrique
28	115000004	Bornier à 3 voies	61	117100076	PCB
29	136010004	Agrafe	62	109060039	Boîte électrique
30	124020011	Vite	63	117240002	Bague aimantée
31	106000012	Manomètre haute pression	64	117240003	Bague aimantée
32	109060055	Panneau arrière	65	117010122	Module WIFI
33	110000039	Connecteur de fil			

UX17Csi32

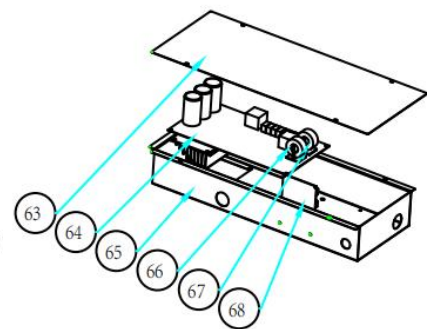
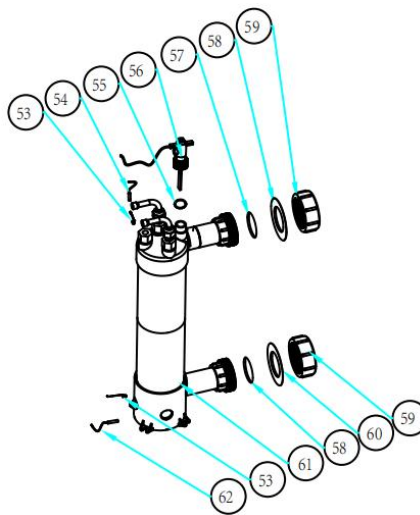
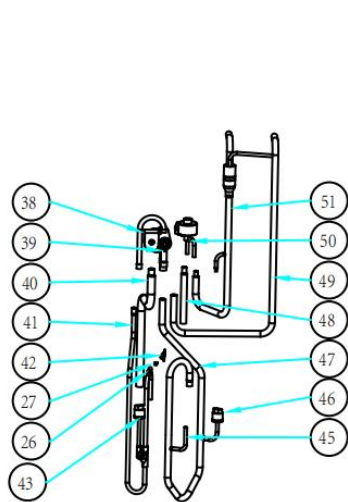
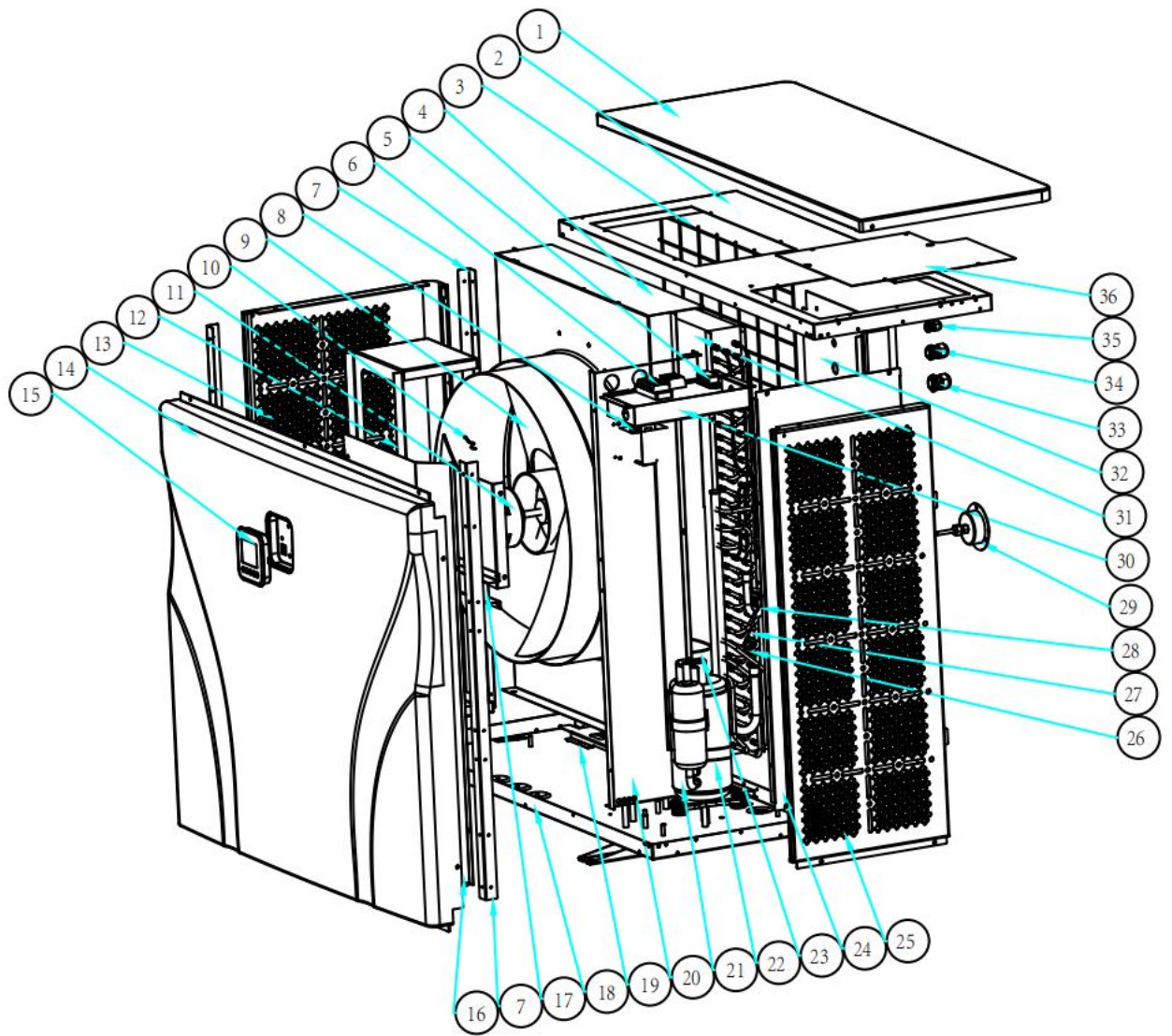

**UX17Csi32**

NO.	ERP	Part name	NO.	ERP	Part name
1	108960050	Le couvercle supérieur	35	110000036	Connecteur de fil
2	108960057	Cadre supérieur	36	108960053	Panneau de service
3	108840091	Grille arrière	37	/	/
4	108960061	Panneau de ventilateur	38	121000037	Bobine de vanne 4 voies
5	136010004	Agrafe	39	121000034	Vanne à quatre voies
6	115000004	Bornier à 3 voies	40	113060208	Tube
7	108960037	Pilier	41	113010440	Tube
8	117230003	Réacteur	42	117110050	Capteur de température de l'évaporateur
9	132000023	Pale de ventilateur	43	116000067	Pressostat haute pression
10	112000031	Moteur de ventilateur	44	/	/
11	117110063	Temp. Ambiante capteur	45	/	Tube
12	108960060	Support de moteur de ventilateur	46	116000073	Pressostat basse pression
13	108960073	panneau de gauche	47	113020673	Tube
14	133450001	Panneau avant	48	113080128	Tube
15	117020293	Contrôleur	49	113030212	Tube
16	108960062	Panneau de service	50	119000058	EEV
17	108960052	Pilier	51	113070065	Tube
18	108960074	Plateau de base	52	/	/
19	108960002	Support d'évaporateur	53	108010025	Agrafe
20	108960063	Panneau d'isolation	54	117110057	Temp. Sortie eau capteur
21	101000181	Compresseur	55	136010072	Anneau en caoutchouc sur le raccordement à l'eau
22	142000074	Résistance de chauffage du compresseur	56	116000065	Interrupteur de débit d'eau
23	142000142	Résistance de chauffage de l'évaporateur	57	133020007	Couverture en PVC
24	108960065	Panneau de service	58	133020012	Anneau en caoutchouc sur le raccordement à l'eau
25	108960072	Panneau droit	59	102050004	Kits de raccordement à l'eau
26	113190001	Support de capteur	60	133020011	Anneau en caoutchouc sur le raccordement à l'eau
27	113190007	Agrafe	61	102041110	Échangeur de chaleur en titane
28	117110061	Temp de décharge. capteur	62	117110053	Temp entrée d'eau. capteur
29	106000012	Manomètre haute pression	63	108960007	Couvercle de boîte électrique
30	108960058	Boîtier de câblage	64	117100076	PCB
31	103000360	Évaporateur	65	108960054	Boîte électrique
32	108960075	Panneau arrière	66	117240002	Bague aimantée
33	110000048	Connecteur de fil	67	117240003	Bague aimantée
34	110000039	Connecteur de fil	68	117010122	Module WIFI

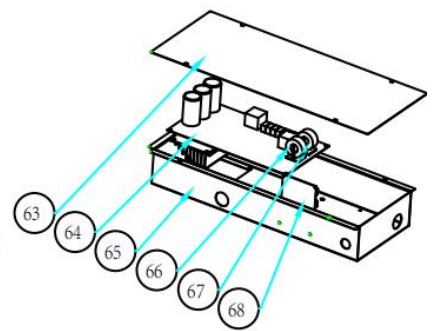
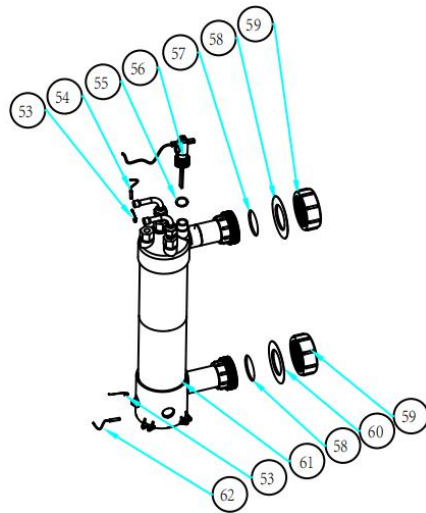
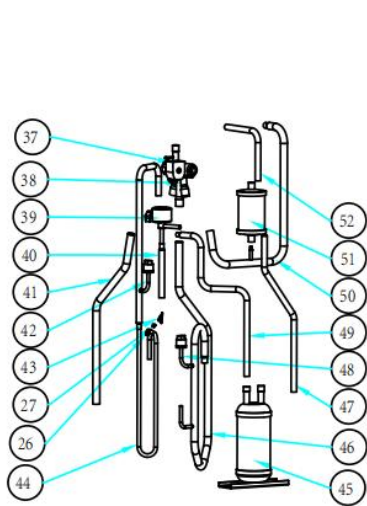
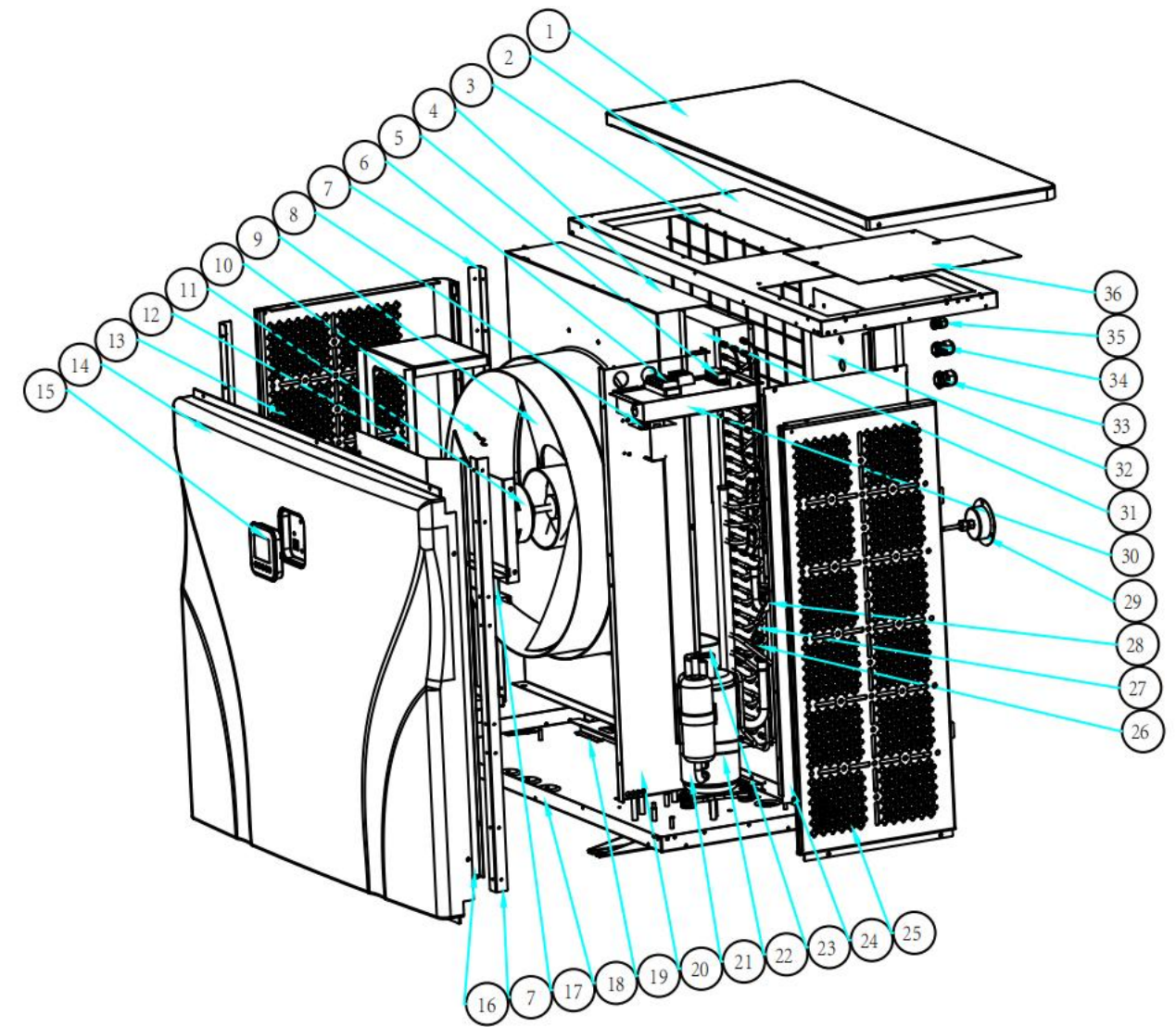

**UX21Csi32**

NO.	ERP	Part name	NO.	ERP	Part name
1	108960050	Le couvercle supérieur	35	110000036	Connecteur de fil
2	108960057	Cadre supérieur	36	108960053	Panneau de service
3	108840091	Grille arrière	37	121000028	Vanne à quatre voies
4	108960061	Panneau de ventilateur	38	121000037	Bobine de vanne 4 voies
5	136010004	Agrafe	39	119000066	EEV
6	115000004	Bornier à 3 voies	40	113080128	Tube
7	108960037	Pilier	41	113060193	Tube
8	117230003	Réacteur	42	116000068	Pressostat haute pression
9	132000023	Pale de ventilateur	43	117110050	Capteur de température de l'évaporateur
10	112000031	Moteur de ventilateur	44	113010434	Tube
11	117110063	Temp. Ambiante capteur	45	105000004	Réservoir de stockage de liquide
12	108960060	Support de moteur de ventilateur	46	113020683	Tube
13	108960073	panneau de gauche	47	113130041	Tube
14	133450001	Panneau avant	48	116000073	Pressostat basse pression
15	117020293	Contrôleur	49	113120065	Tube
16	108960062	Panneau de service	50	113030216	Tube
17	108960052	Pilier	51	120000066	Filtre déshydrateur
18	108960079	Plateau de base	52	113170079	Tube
19	108960002	Support d'évaporateur	53	108010025	Agrafe
20	108960063	Panneau d'isolement	54	117110057	Temp. Sortie eau capteur
21	101000252	Compresseur	55	136010072	Anneau en caoutchouc sur le raccordement à l'eau
22	142000072	Résistance de chauffage du compresseur	56	116000065	Interrupteur de débit d'eau
23	142000142	Résistance de chauffage de l'évaporateur	57	133020007	Couverture en PVC
24	108960065	Panneau de service	58	133020012	Anneau en caoutchouc sur le raccordement à l'eau
25	108960072	Panneau droit	59	102050004	Kits de raccordement à l'eau
26	113190001	Support de capteur	60	133020011	Anneau en caoutchouc sur le raccordement à l'eau
27	113190007	Agrafe	61	102041110	Échangeur de chaleur en titane
28	117110061	Temp de décharge. capteur	62	117110053	Temp entrée d'eau. capteur
29	106000012	Manomètre haute pression	63	108960007	Couvercle de boîte électrique
30	108960058	Boîtier de câblage	64	117100076	PCB
31	103000337	Évaporateur	65	108960054	Boîte électrique
32	108960075	Panneau arrière	66	117240002	Bague aimantée
33	110000048	Connecteur de fil	67	117240003	Bague aimantée
34	110000039	Connecteur de fil	68	117010122	Module WIFI

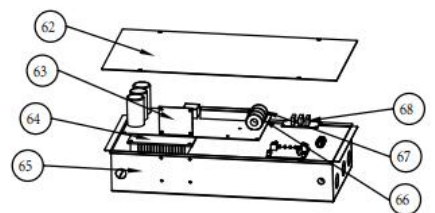
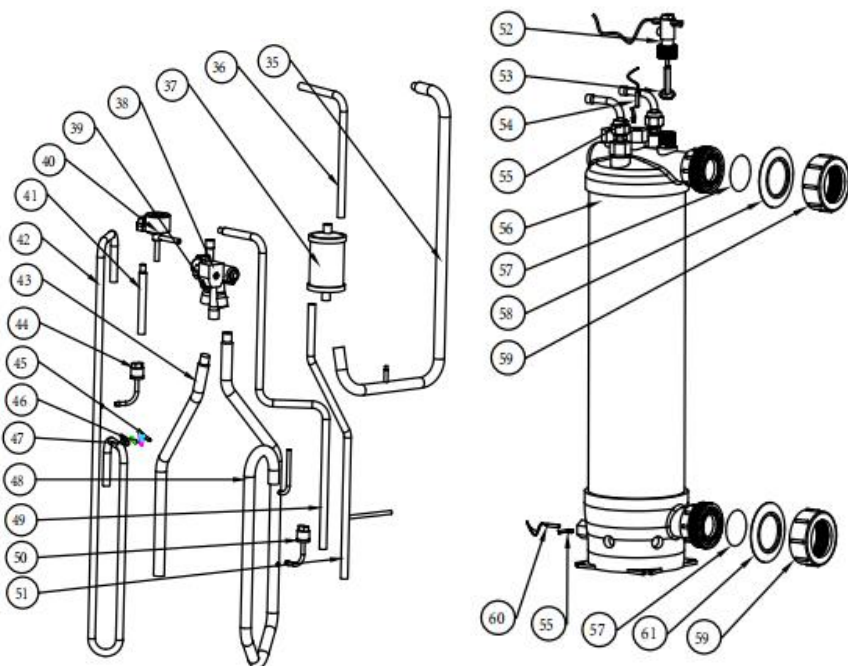
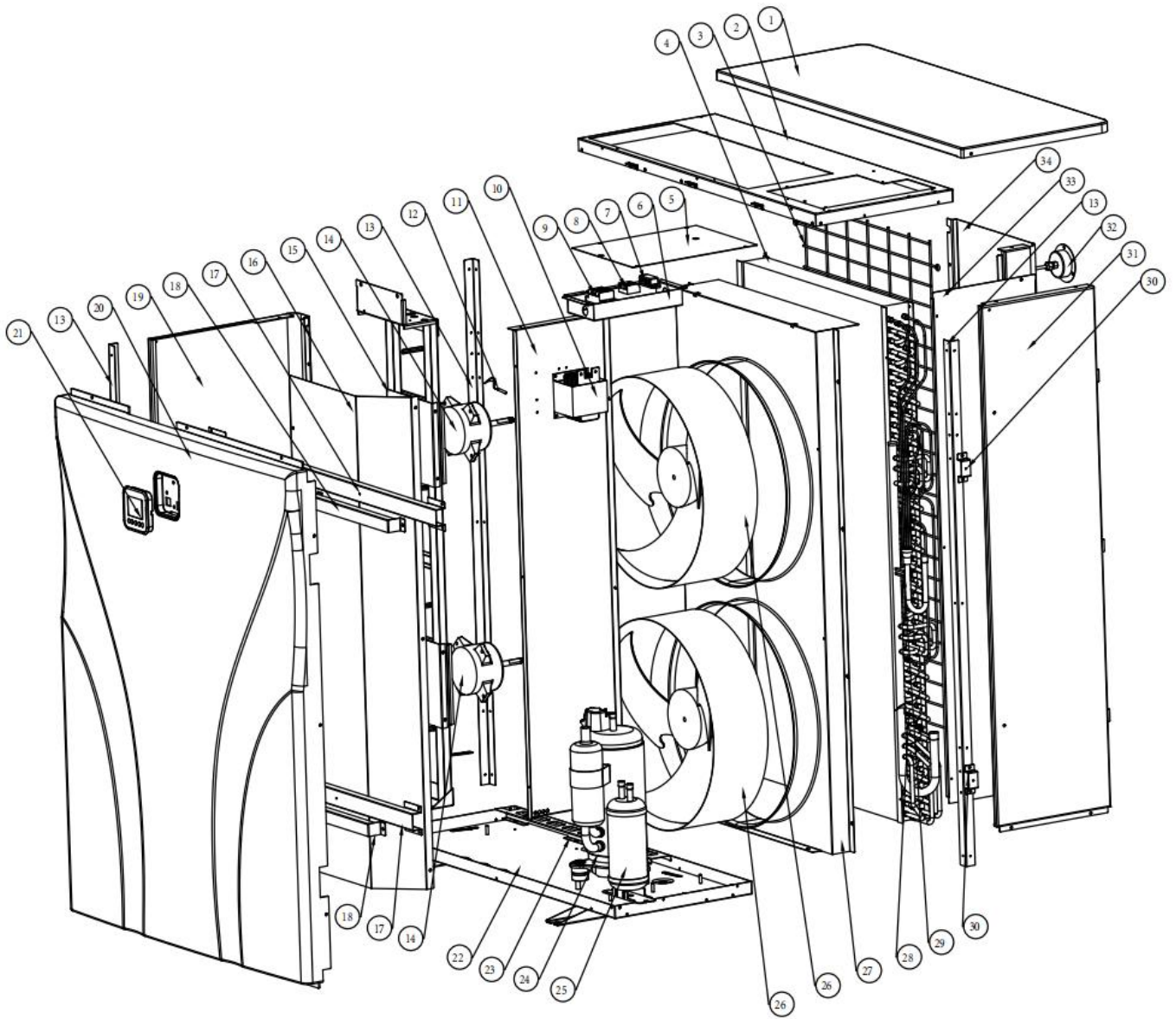



**UX26Csi32**

NO.	ERP	Part name	NO.	ERP	Part name
1	108940051	Le couvercle supérieur	35	113030215	Tube
2	108940059	Cadre supérieur	36	113170078	Tube
3	108940012	Grille arrière	37	120000066	Filtre déshydrateur
4	103000354	Évaporateur	38	121000037	Bobine de vanne 4 voies
5	108940034	Panneau de service	39	121000028	Vanne à quatre voies
6	108960058	Boîtier de câblage	40	119000059	EEV
7	136010004	Agrafe	41	113080116	Tube
8	115000012	Bornier à 3 voies	42	113020621	Tube
9	115000025	Bornier à 3 voies	43	113060211	Tube
10	117230002	Réacteur	44	116000068	Pressostat haute pression
11	108940060	Panneau d'isolement	45	117110051	Temp de décharge. capteur
12	117110063	Temp. Ambiante capteur	46	113190007	Agrafe
13	108940047	Pilier	47	113190001	Support de capteur
14	112000031	Moteur de ventilateur	48	113020703	Tube
15	108940016	Support de moteur de ventilateur	49	113130040	Tube
16	108940035	Panneau de service	50	116000073	Pressostat basse pression
17	108940048	Pilier	51	113120063	Tube
18	108960081	Pilier	52	116000065	Interrupteur de débit d'eau
19	108940057	panneau de gauche	53	136010089	Anneau en caoutchouc sur le raccordement à l'eau
20	133480002	Panneau avant	54	117110057	Temp. Sortie eau capteur
21	117020293	Contrôleur	55	108010025	Agrafe
22	108940043	Plateau de base	56	102041127	Échangeur de chaleur en titane
23	108940004	Support d'évaporateur	57	133020007	Couverture en PVC
24	101000185	Compresseur	58	133020012	Anneau en caoutchouc sur le raccordement à l'eau
25	105000015	Réservoir de stockage de liquide	59	102050004	Kits de raccordement à l'eau
26	132000015	Pale de ventilateur	60	117110053	Temp entrée d'eau. capteur
27	108940056	Panneau de ventilateur	61	133020011	Anneau en caoutchouc sur le raccordement à l'eau
28	117110050	Capteur de température de l'évaporateur	62	108940062	Couvercle de boîte électrique
29	136020005	Bloc en caoutchouc	63	117010122	Module WIFI
30	109070064	Pilier	64	117100077	PCB
31	108940058	Panneau droit	65	108940061	Boîte électrique
32	106000012	Manomètre haute pression	66	117240002	Bague aimantée
33	108940036	Panneau de service	67	117240003	Bague aimantée
34	108940053	Panneau arrière	68	117010081	Clip

UX30Csi32/UX30Csi32T/UX35Csi32T

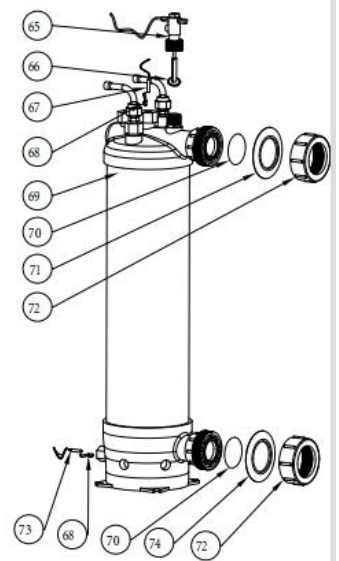
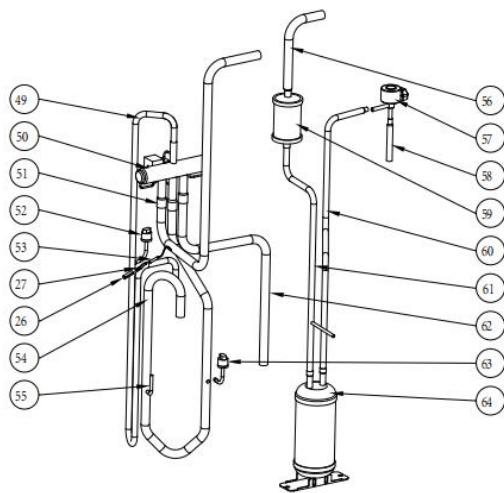
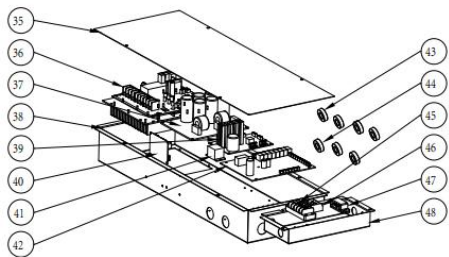
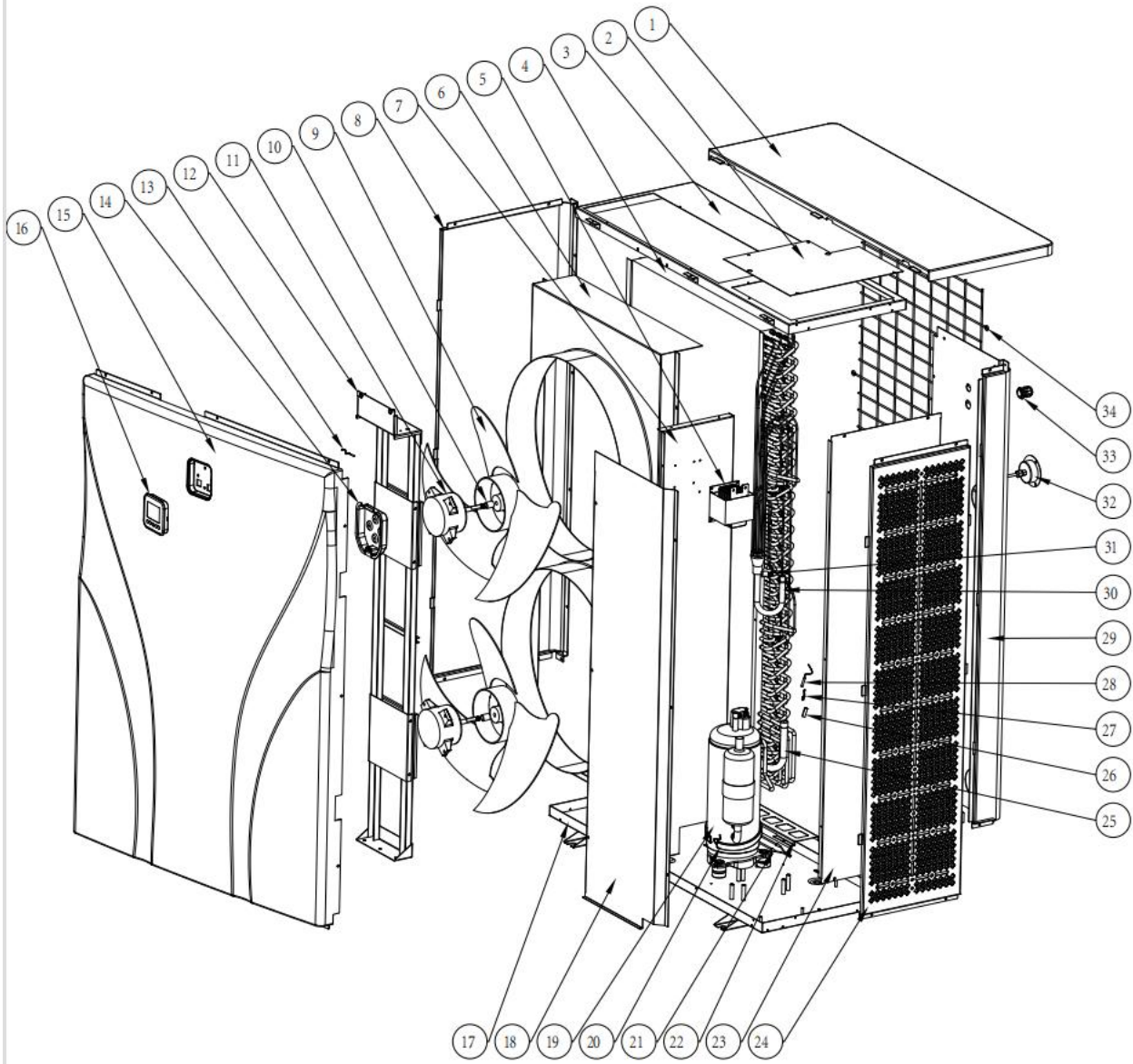

**UX30Csi32**

NO.	ERP	Part name	NO.	ERP	Part name
1	109070060	Le couvercle supérieur	38	109070006	Boîte électrique
2	109070052	Panneau de service	39	/	/
3	109070051	Cadre supérieur	40	117010122	Module WIFI
4	103000331	Évaporateur	41	142000038	Relais
5	117230002	Réacteur	42	117250021	PCB
6	109070019	Panneau de ventilateur	43	117240002	Bague aimantée
7	109070026	Panneau d'isolement	44	117240003	Bague aimantée
8	109070057	panneau de gauche	45	115000025	Bornier à 3 voies
9	132000023	Pale de ventilateur	46	115000023	Bornier à 3 voies
10	108010024	Groupe motoventilateur	47	136010004	Agrafe
11	112000031	Moteur de ventilateur	48	108960058	Boîtier de câblage
12	109070021	Support de moteur de ventilateur	49	113010444	Tube
13	117110063	Temp. Ambiante capteur	50	121000028	Vanne à quatre voies
14	133030020	Boîtier de contrôleur	51	113030183	Tube
15	133460001	Panneau avant	52	116000068	Pressostat haute pression
16	117020293	Contrôleur	53	117110051	Temp de décharge. capteur
17	109070065	Plateau de base	54	113020684	Tube
18	109070053	Panneau de service	55	113020685	Tube
19	101000185	Compresseur	56	113070061	Tube
20	142000077	Résistance de chauffage du compresseur	57	119000061	EEV
21	142000079	Résistance de chauffage de l'évaporateur	58	113080116	Tube
22	109070004	Support d'évaporateur	59	120000066	Filtre déshydrateur
23	109070054	Panneau de service	60	113120053	Tube
24	109070058	Panneau droit	61	113130039	Tube
25	103000331	Tuyau d'évaporateur	62	113060214	Tube
26	113190001	Support de capteur	63	116000073	Pressostat basse pression
27	113190007	Agrafe	64	105000015	Réservoir de stockage de liquide
28	117110050	Capteur de température de l'évaporateur	65	116000065	Interrupteur de débit d'eau
29	109070062	Panneau arrière	66	136020083	Anneau en caoutchouc sur le raccordement à l'eau
30	103000331	Tuyau d'évaporateur	67	117110057	Temp. Sortie eau capteur
31	136020005	Bloc en caoutchouc	68	108010025	Agrafe
32	106000012	Manomètre haute pression	69	102041106	Échangeur de chaleur en titane
33	110000038	Connecteur de fil	70	133020006	Anneau en caoutchouc sur le raccordement à l'eau
34	109070022	Grille arrière	71	133020012	Anneau en caoutchouc sur le raccordement à l'eau
35	109070007	Couvercle de boîte électrique	72	102050004	Kits de raccordement à l'eau
36	117140016	Carte pilote triphasée	73	117110053	Temp entrée d'eau. capteur
37	117260001	Panneau filtre	74	133020011	Anneau en caoutchouc sur le raccordement à l'eau

**UX30Csi32T**

NO.	ERP	Part name	NO.	ERP	Part name
1	109070060	Le couvercle supérieur	38	109070006	Boîte électrique
2	109070052	Panneau de service	39	/	/
3	109070051	Cadre supérieur	40	117010122	Module WIFI
4	103000331	Évaporateur	41	142000038	Relais
5	117230002	Réacteur	42	117250022	PCB
6	109070019	Panneau de ventilateur	43	117240002	Bague aimantée
7	109070068	Panneau d'isolement	44	117240003	Bague aimantée
8	109070070	panneau de gauche	45	115000006	Bornier à 3 voies
9	132000023	Pale de ventilateur	46	115000023	Bornier à 3 voies
10	108010024	Groupe motoventilateur	47	136010004	Agrafe
11	112000031	Moteur de ventilateur	48	108960058	Boîtier de câblage
12	109070021	Support de moteur de ventilateur	49	113020636	Tube
13	117110063	Temp. Ambiante capteur	50	121000028	Vanne à quatre voies
14	133030020	Boîtier de contrôleur	51	113030183	Tube
15	133460001	Panneau avant	52	116000068	Pressostat haute pression
16	117020293	Contrôleur	53	117110051	Temp de décharge. capteur
17	180060001	Plateau de base	54	113020697	Tube
18	109070069	Panneau de service	55	/	Tube
19	101000239	Compresseur	56	113070061	Tube
20	142000077	Résistance de chauffage du compresseur	57	119000061	EEV
21	142000079	Résistance de chauffage de l'évaporateur	58	113080116	Tube
22	109070004	Support d'évaporateur	59	120000066	Filtre déshydrateur
23	109070066	Panneau de service	60	113120053	Tube
24	109070058	Panneau droit	61	113130039	Tube
25	103000331	Tuyau d'évaporateur	62	113060214	Tube
26	113190001	Support de capteur	63	116000073	Pressostat basse pression
27	113190007	Agrafe	64	105000015	Réservoir de stockage de liquide
28	117110050	Capteur de température de l'évaporateur	65	116000065	Interrupteur de débit d'eau
29	109070062	Panneau arrière	66	136020083	Anneau en caoutchouc sur le raccordement à l'eau
30	103000331	Tuyau d'évaporateur	67	117110057	Temp. Sortie eau capteur
31	136020005	Bloc en caoutchouc	68	108010025	Agrafe
32	106000012	Manomètre haute pression	69	102041106	Échangeur de chaleur en titane
33	110000038	Connecteur de fil	70	133020006	Anneau en caoutchouc sur le raccordement à l'eau
34	109070022	Grille arrière	71	133020012	Anneau en caoutchouc sur le raccordement à l'eau
35	109070007	Couvercle de boîte électrique	72	102050004	Kits de raccordement à l'eau
36	117140019	Carte pilote triphasée	73	117110053	Temp entrée d'eau. capteur
37	117260002	Panneau filtre	74	133020011	Anneau en caoutchouc sur le raccordement à l'eau

**UX35Csi32T**

NO.	ERP	Part name	NO.	ERP	Part name
1	109070060	Le couvercle supérieur	38	109070006	Boîte électrique
2	109070052	Panneau de service	39	/	/
3	109070051	Cadre supérieur	40	117010122	Module WIFI
4	103000356	Évaporateur	41	142000038	Relais
5	117230002	Réacteur	42	117250022	PCB
6	109070019	Panneau de ventilateur	43	117240002	Bague aimantée
7	109070068	Panneau d'isolement	44	117240003	Bague aimantée
8	109070070	panneau de gauche	45	115000006	Bornier à 3 voies
9	132000023	Pale de ventilateur	46	115000023	Bornier à 3 voies
10	108010024	Groupe motoventilateur	47	136010004	Agrafe
11	112000031	Moteur de ventilateur	48	108960058	Boîtier de câblage
12	109070021	Support de moteur de ventilateur	49	113020636	Tube
13	117110063	Temp. Ambiante capteur	50	121000028	Vanne à quatre voies
14	133030020	Boîtier de contrôleur	51	113030183	Tube
15	133460001	Panneau avant	52	116000068	Pressostat haute pression
16	117020293	Contrôleur	53	117110051	Temp de décharge. capteur
17	180060001	Plateau de base	54	113020697	Tube
18	109070069	Panneau de service	55	/	Tube
19	101000239	Compresseur	56	113070061	Tube
20	142000077	Résistance de chauffage du compresseur	57	119000061	EEV
21	142000079	Résistance de chauffage de l'évaporateur	58	113080116	Tube
22	109070004	Support d'évaporateur	59	120000066	Filtre déshydrateur
23	109070066	Panneau de service	60	113120053	Tube
24	109070058	Panneau droit	61	113130039	Tube
25	103000356	Tuyau d'évaporateur	62	113060214	Tube
26	113190001	Support de capteur	63	116000073	Pressostat basse pression
27	113190007	Agrafe	64	105000015	Réservoir de stockage de liquide
28	117110050	Capteur de température de l'évaporateur	65	116000065	Interrupteur de débit d'eau
29	109070062	Panneau arrière	66	136020083	Anneau en caoutchouc sur le raccordement à l'eau
30	103000356	Tuyau d'évaporateur	67	117110057	Temp. Sortie eau capteur
31	136020005	Bloc en caoutchouc	68	108010025	Agrafe
32	106000012	Manomètre haute pression	69	102041106	Échangeur de chaleur en titane
33	110000038	Connecteur de fil	70	133020006	Anneau en caoutchouc sur le raccordement à l'eau
34	109070022	Grille arrière	71	133020012	Anneau en caoutchouc sur le raccordement à l'eau
35	109070007	Couvercle de boîte électrique	72	102050004	Kits de raccordement à l'eau
36	117140019	Carte pilote triphasée	73	117110053	Temp entrée d'eau. capteur
37	117260002	Panneau filtre	74	133020011	Anneau en caoutchouc sur le raccordement à l'eau

# **Manuale di Installazione e Uso**

## **INVERBOOST INVERTER**

**Regolamento (UE) n ° 517/2014 del 16/04/14 sui gas serra fluorurati ad effetto serra e che abroga il regolamento (CE) n ° 842/2006**

---

**Controlli di perdite**

1. Gli operatori delle apparecchiature che contengono gas fluorurati ad effetto serra con quantità di 5 tonnellate di CO<sub>2</sub>, equivalenti o superiore e non contiene nelle schiume, devono garantire che il materiale sia stato verificato la presenza di perdite.
2. Per le apparecchiature che contengono gas fluorurati ad effetto serra con quantità di 5 tonnellate di CO<sub>2</sub> equivalente o superiore, ma inferiore a 50 tonnellate di CO<sub>2</sub> equivalente: controllare almeno ogni 12 mesi.

**Immagine del CO<sub>2</sub> dell'equivalenza**

1. Caricare il totale CO<sub>2</sub> in chili e tonnellate.

<b>Caricare il totale CO<sub>2</sub> in chili e tonnellate</b>	<b>Frequenza di test</b>
<b>Dal 7 a 75 chili di carico = dal 5 a 50 tonnellate</b>	<b>Annuale</b>

**Per quanto riguarda la Gaz R32, 7.40 chili pari a 5 tonnellate di CO<sub>2</sub>, l'obbligo a controllare ogni anno.**

**Formazione e certificazione**

1. Il gestore della relativa domanda deve assicurare che il personale interessato abbia ottenuto la certificazione necessaria, che implica una conoscenza appropriata dei regolamenti e delle norme vigenti, nonché la necessaria competenza in materia di prevenzione delle emissioni e di recupero dei gas fluorurati ad effetto serra e la sicurezza la gestione dell'apparecchiatura del relativo tipo e dimensioni.

**Conservazione di registri**

1. Gli operatori di attrezzatura che è necessario per controllare la presenza di perdite, deve stabilire e mantenere i record per ogni pezzo di tali attrezzature specificando le seguenti informazioni:
  - a) La quantità e il tipo di gas fluorurati ad effetto serra installati;
  - b) Le quantità di gas fluorurati ad effetto serra aggiunte durante l'installazione, manutenzione o assistenza o a causa di perdite;
  - c) Se la quantità di gas fluorurati ad effetto serra installate sono state riciclate e rigenerate, insieme al nome e l'indirizzo del centro di riciclaggio o recupero e, se del caso, il numero del certificato;
  - d) la quantità di gas fluorurati ad effetto serra recuperata
  - e) L'identità dell'impresa che ha installato, servito, mantenuto e, se del caso riparato o decommissionato le attrezzature, include, se del caso, il numero del proprio certificato;
  - f) Le date ei risultati dei controlli effettuati;
  - g) Se l'apparecchiatura è stata decommissionata, le misure adottate per recuperare e sistemare i gas fluorurati ad effetto serra.
2. **L'operatore deve conservare i registri per almeno cinque anni, le imprese che svolgono le attività per gli operatori devono tenere copie dei registri per almeno cinque anni.**

## INDICE

1. Specifiche
2. Dimensione
3. Installazione e collegamento
4. Regolazione del bypass
5. Visualizza Operazione di controllo
6. Risoluzione dei problemi
7. Schema
8. Manutenzione
9. Esploso

Grazie per aver scelto INVERBOOST INVERTER pompa di calore della piscina per il riscaldamento della piscina, che riscalderà l'acqua della piscina e mantenere la temperatura costante quando la temperatura ambiente dell'aria è a -20 a 43 °C.

**▲ ATTENZIONE:** Questo manuale contiene tutte le informazioni necessarie con l'uso e l'installazione della pompa di calore.

L'installazione deve leggere il manuale e attentamente seguire le istruzioni nella implementazione e manutenzione. L'installazione è responsabile dell'installazione del prodotto e deve seguire tutte le istruzioni del produttore e le normative di applicazione. L'installazione non corretta contro manuale comporta l'esclusione di tutta garanzia. Il costruttore declina ogni responsabilità per i danni causati alle persone, oggetti e degli errori a causa della installazione che disobbedire alla guida manuale. Qualsiasi uso che è senza conforme all'origine della sua produzione sarà considerato pericoloso.

**ATTENZIONE:** Si prega di svuotare sempre l'acqua a pompa di calore durante la stagione invernale o quando la temperatura scende sotto 0 °C, altrimenti lo scambiatore di titanio viene danneggiato a causa di essere congelato, in tal caso, la garanzia sarà perso.

**ATTENZIONE:** Si prega di tagliare sempre l'alimentazione elettrica se si desidera aprire l'armadio per raggiungere all'interno della pompa di calore, perché non c'è energia elettrica ad alta tensione all'interno.

**ATTENZIONE:** Si prega di tenere bene la scheda video in un luogo asciutto, o ben chiudere il coperchio isolante per proteggere la scheda video venga danneggiato dall'umidità.



# 1. Specifiche

Modello		UX11Csi32	UX14Csi32	UX17Csi32
<b>* Performance con Aria a 28°C, Acqua a 28°C, Umidità all'80%</b>				
Turbo Capacità di riscaldamento	kW	11.0	14.0	17.0
Smart Capacità di riscaldamento	kW	10.0	11.0	14.0
Consumo energetico	kW	1.55-0.17	1.97-0.22	2.39-0.27
C.O.P.		16-7.4	16-7.1	16-7.2
C.O.P. in Turbo Modalità		7.4	7.1	7.2
C.O.P. at 50% capacità		11.8	11.0	11.8
<b>* Performance con Aria a 15°C, Acqua a 26°C, Umidità al 70%</b>				
Turbo Capacità di riscaldamento	kW	8.5	9.5	12.0
Smart Capacità di riscaldamento	kW	7.0	8.0	10.5
Consumo energetico	kW	1.67-0.26	1.90-0.29	2.31-0.37
C.O.P.		8.2-5.1	8.21-5	8.5-5.2
C.O.P. in Turbo Modalità		5.1	5.0	5.2
C.O.P. at 50% capacità		7.1	7.0	7.8
<b>* Dati generali</b>				
Compressor type		Inverter compressor		
Voltaggio		220-240V/50Hz/1PH		
Corrente nominale	A	6.9	8.7	10.6
Corrente massima	A	10.5	13.5	15.5
Fusibile minimo	A	12.0	15.0	16.0
Portata acqua nominale	m <sup>3</sup> /h	3.7	4.0	5.0
Perdita di carico massima	Kpa	12.0	14.0	15.0
Condensatore		Twist-titanium tube in PVC		
Allacciamento acqua	mm	50		
Fan quantità		1		
Flusso d'aria		Horizontal		
Pressione sonora (10m)	dB(A)	17.8-26.2	21.7-26.7	22.6-28.1
Pressione sonora (1m)	dB(A)	36-46.2	38-47.6	39.5-49.8
<b>* Dimensione / Peso</b>				
Peso netto	kg	73	78	98
Peso lordo	kg	78	83	113
Dimensione netta	mm	1028*441*685	1028*441*685	1073*492*886
Dimensioni di spedizione	mm	1095*525*830	1095*525*830	1140*555*1030

Modello		UX21Csi32	UX26Csi32	UX30Csi32
<b>* Performance con Aria a 28°C, Acqua a 28°C, Umidità all'80%</b>				
Turbo Capacità di riscaldamento	kW	21.0	26.0	30.0
Smart Capacità di riscaldamento	kW	18.0	21.0	25.0
Consumo energetico	kW	2.96-0.33	3.66-0.29	4.17-0.47
C.O.P.		16-7.1	16-7.1	16-7.1
C.O.P. in Turbo Modalità		7.1	7.1	7.1
C.O.P. at 50% capacità		11.2	11.2	11.2
<b>*Performance con Aria a 15°C, Acqua a 26°C, Umidità al 70%</b>				
Turbo Capacità di riscaldamento	kW	15.5	18.0	20.0
Smart Capacità di riscaldamento	kW	13.5	16.0	18.0
Consumo energetico	kW	3.04-0.47	3.53-0.55	3.92-0.61
C.O.P.		8.3-5.1	8.2-5.1	8.2-5.1
C.O.P. in Turbo Modalità		5.1	5.1	5.1
C.O.P. at 50% capacità		7.4	7.2	7.2
<b>* Dati generali</b>				
Compressor type		Inverter compressor		
Voltaggio		220-240V/50Hz/1PH		
Corrente nominale	A	13.1	16.3	18.5
Corrente massima	A	19.5	24.0	28.0
Fusibile minimo	A	22	28	32
Portata acqua nominale	m³/h	6.0	8.0	10.0
Perdita di carico massima	Kpa	15	18	20
Condensatore		Twist-titanium tube in PVC		
Allacciamento acqua	mm	50		
Fan quantità		1	2	2
Flusso d'aria		Horizontal		
Pressione sonora (10m)	dB(A)	22.9-30.6	23.1-31.8	23.2-32.4
Pressione sonora (1m)	dB(A)	40-51	41-51.6	42-51.8
<b>* Dimensione / Peso</b>				
Peso netto	kg	117	125	130
Peso lordo	kg	135	145	148
Dimensione netta	mm	1073*492*886	1039*509*1289	1113*519*1410
Dimensioni di spedizione	mm	1185*530*1030	1185*565*1435	1225*540*1555

Modello		UX30Csi32T	UX35Csi32T
<b>* Performance con Aria a 28°C, Acqua a 28°C, Umidità all'80%</b>			
Turbo Capacità di riscaldamento	kW	30.0	35.0
Smart Capacità di riscaldamento	kW	25.0	30.0
Consumo energetico	kW	4.17-0.47	4.93-0.55
C.O.P.		16-7.1	16-7.1
C.O.P. in Turbo Modalità		7.1	7.1
C.O.P. at 50% capacità		11.2	11.2
<b>* Performance con Aria a 15°C, Acqua a 26°C, Umidità al 70%</b>			
Turbo Capacità di riscaldamento	kW	20.0	24.0
Smart Capacità di riscaldamento	kW	18.0	22.0
Consumo energetico	kW	3.85-0.61	4.62-0.73
C.O.P.		8.2-5.2	8.2-5.2
C.O.P. in Turbo Modalità		5.2	5.2
C.O.P. at 50% capacità		7.2	7.2
<b>* Dati generali</b>			
Compressor type		Inverter compressor	
Voltaggio		380V/50Hz/3PH	
Corrente nominale	A	7.5	8.8
Corrente massima	A	12.0	14.0
Fusibile minimo	A	15	17
Portata acqua nominale	m <sup>3</sup> /h	10.0	15.0
Perdita di carico massima	Kpa	20	25
Condensatore		Twist-titanium tube in PVC	
Allacciamento acqua	mm	50	
Fan quantità		2	2
Flusso d'aria		Horizontal	
Pressione sonora (10m)	dB(A)	23.2-32.4	23.4-32.8
Pressione sonora (1m)	dB(A)	42-51.8	42.8-52
<b>* Dimensione / Peso</b>			
Peso netto	kg	130	135
Peso lordo	kg	148	150
Dimensione netta	mm	1113*519*1410	1113*519*1410
Dimensioni di spedizione	mm	1225*540*1555	1225*540*1555

\* Above data may be modified without notice.

## 2. Dimensione

UX11Csi32/UX14Csi32

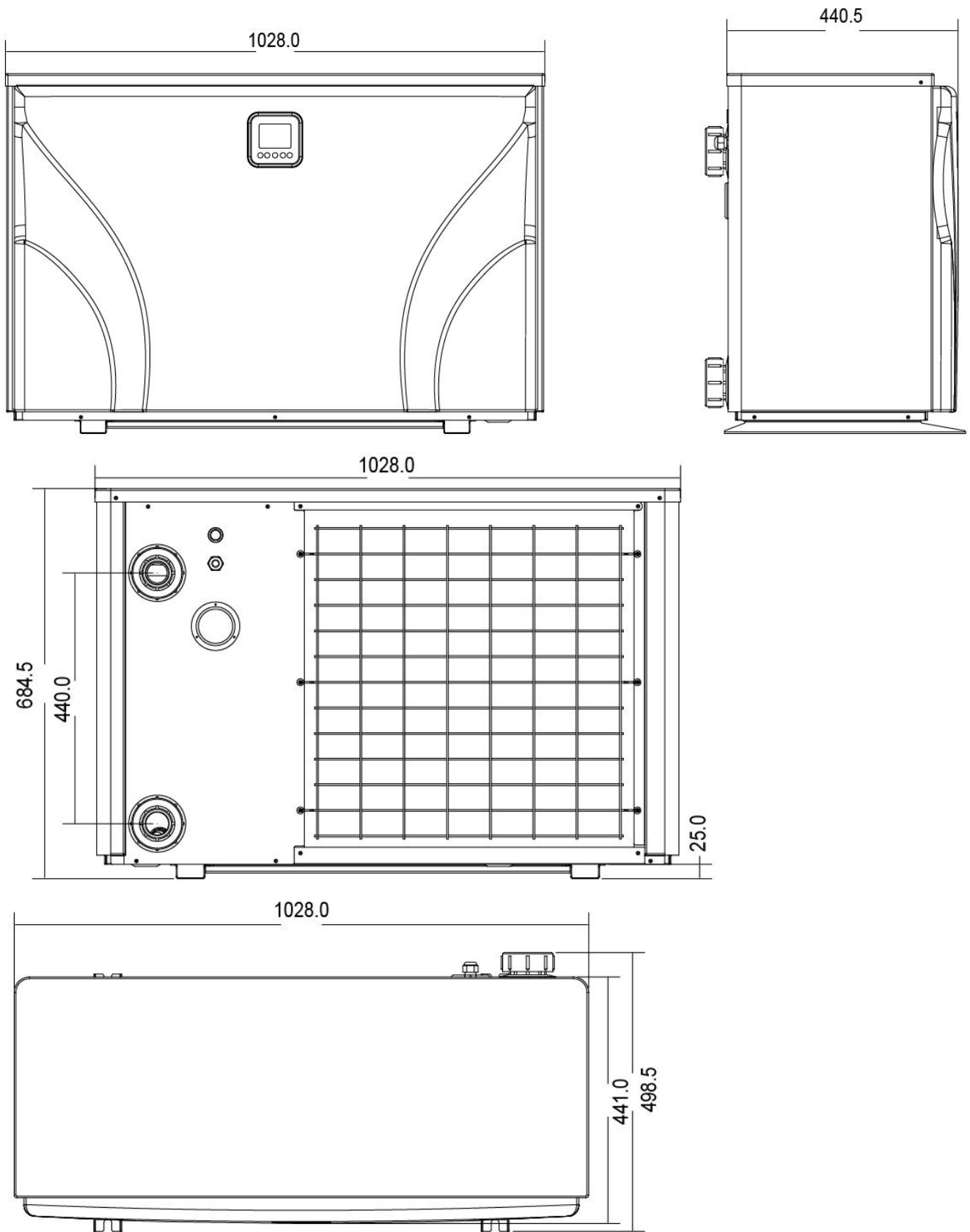

UX17Csi32/UX21Csi32

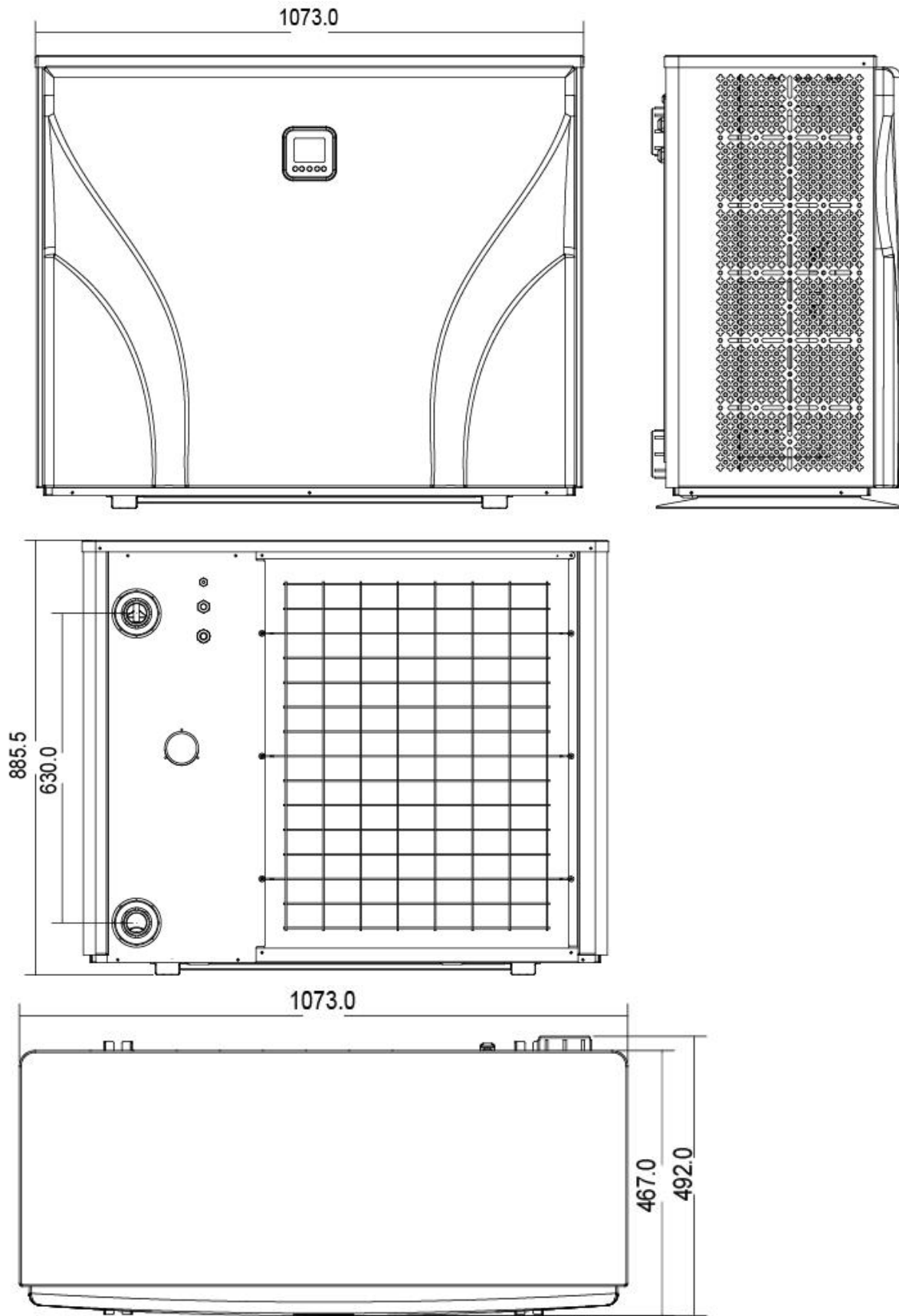

UX26Csi32

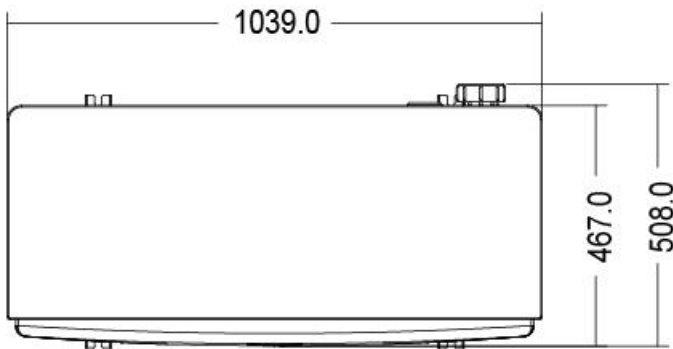
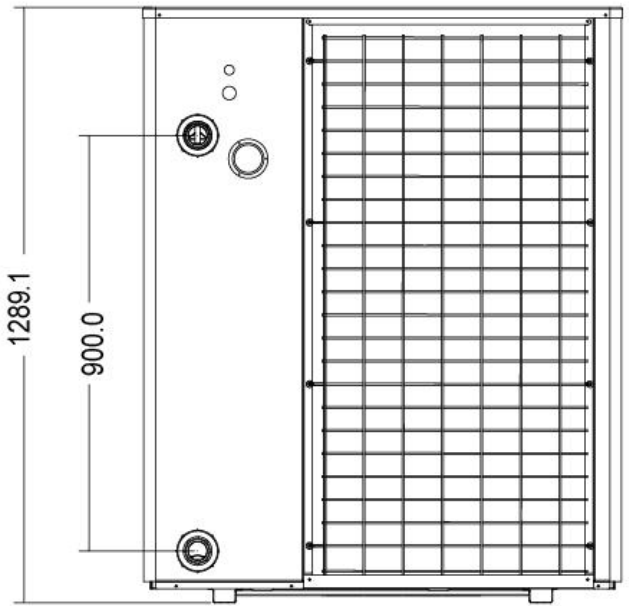
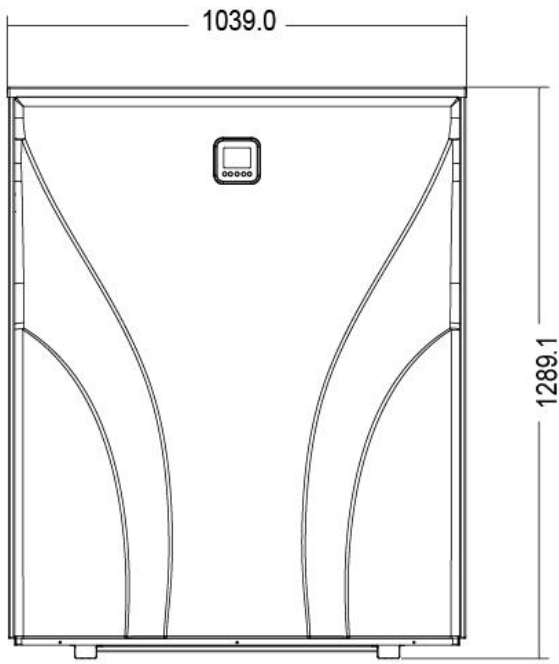

UX30Csi32/UX30Csi32T/UX35Csi32T

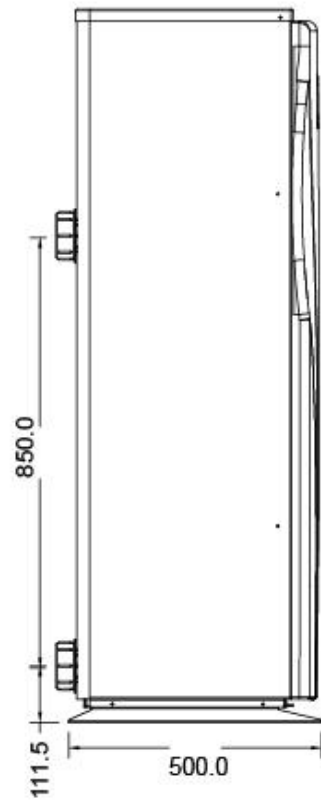
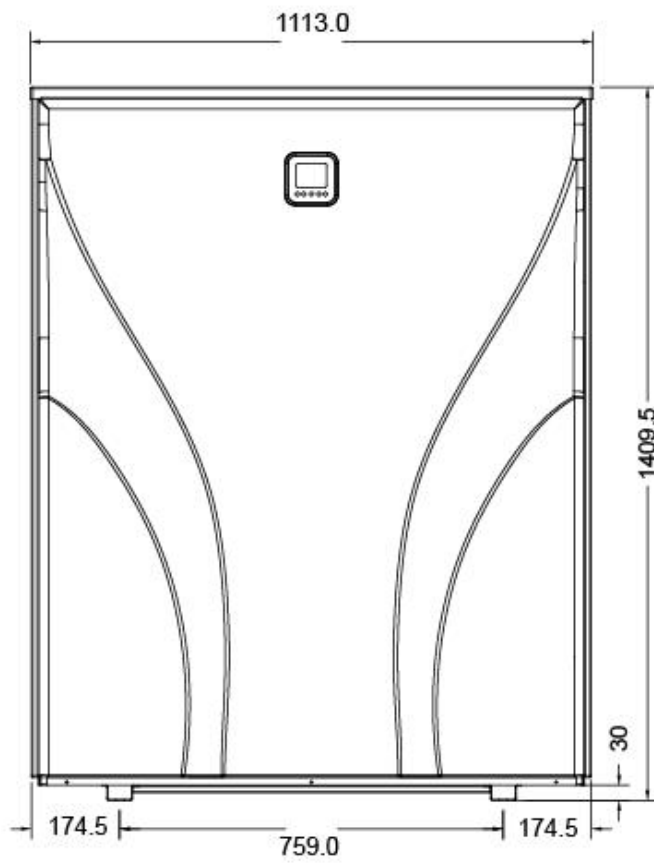

Unit: mm

### 3. Installazione e collegamento

#### 3.1 Installazione



##### **Basi antivibranti**

1. Estrarre 4 basi antivibranti
2. Inserire uno per uno sul fondo della macchina come l'immagine.

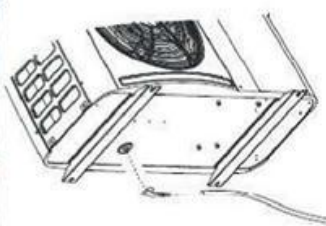

##### **Jet drenante**

1. Installare il getto di scarico sotto il pannello inferiore
2. Collegare con un tubo di acqua per drenare l'acqua.

Nota: Sollevare la pompa di calore per installare il getto. Sempre ribaltare il cuore pompa, potrebbe danneggiare il compressore.



##### **Ingresso acqua & svincolo di uscita**

1. Usare il nastro del tubo per collegare l'acqua in ingresso e uscita svincolo sulla pompa di calore
2. Installare le due articolazioni come l'immagine mostra
3. loro vite sull'acqua in ingresso e uscita svincolo



##### **Cablaggio del cavo di rete**

1. Aprire il coperchio del quadro elettrico all'interno della macchina
2. Collegare i cavi nel terminale corretto secondo lo schema elettrico.





### Cablaggio della pompa di filtrazione (contatto a secco)

1. Aprire il coperchio del quadro elettrico all'interno della macchina
2. Collegare i cavi nel terminale corretto secondo lo schema elettrico.

### Collegamento per pilotare la pompa dell'acqua

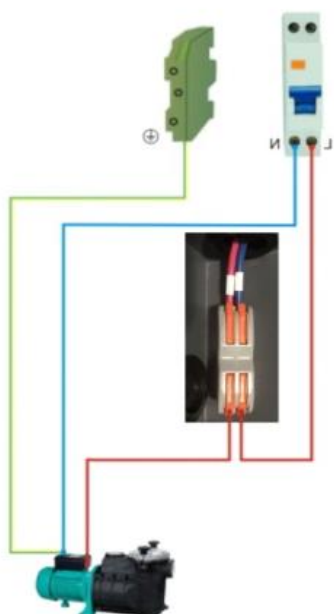
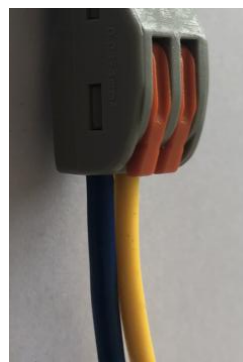
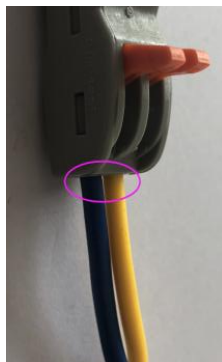
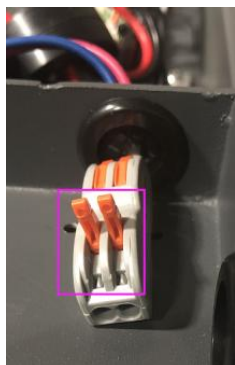

### Notes

I rifornimenti della fabbrica soltanto la pompa di calore. Tutti gli altri componenti, tra cui un bypass, se necessario, devono essere forniti dall'utente o dall'installatore.

### Attenzione:

Si prega di osservare le seguenti regole durante l'installazione della pompa di calore:

1. Si prega di rispettare le seguenti regole durante l'installazione della pompa di calore:
2. L'eventuale aggiunta di prodotti chimici deve avvenire nelle tubazioni a valle della pompa di calore.
3. Installare un bypass se il flusso dell'acqua dalla pompa piscina è superiore al 20% maggiore della portata consentita attraverso lo scambiatore di calore della pompa di calore.
4. Installare la pompa di calore al di sopra del livello dell'acqua della piscina.

5. Collocare sempre la pompa di calore su un solido fondamento e utilizzare i supporti in gomma in dotazione per evitare vibrazioni e rumori.

6. Tenere sempre la pompa di calore in posizione verticale. Se l'unità è stata tenuta in un angolo, attendere almeno 24 ore prima di avviare la pompa di calore.

### 3.2 Posizione Pompa di calore

L'unità funziona correttamente in qualsiasi posizione desiderata finchè i seguenti tre elementi sono presenti:

#### 1. Aria fresca - 2. Elettricità - filtri piscina 3. Nuoto

L'unità può essere installata praticamente in qualsiasi luogo all'aperto fino a quando le distanze minime indicate ad altri oggetti vengono mantenuti (vedi disegno qui sotto). Si prega di consultare il programma di installazione per installazione con una piscina coperta. L'installazione in una posizione ventosa non presenta alcun problema, a differenza della situazione con un riscaldatore a gas (compresi problemi fiamma pilota).

**ATTENZIONE:** Non installare l'unità in una stanza chiusa con un volume limitato aria in cui verrà riutilizzato l'aria espulsa dal gruppo, o in prossimità di arbusti che potrebbe bloccare l'ingresso dell'aria. Tali luoghi pregiudicano la fornitura continua di aria fresca, con conseguente ridotta efficienza e possibilmente prevenire produzione di calore sufficiente. Vedere il disegno sottostante per le dimensioni minime.

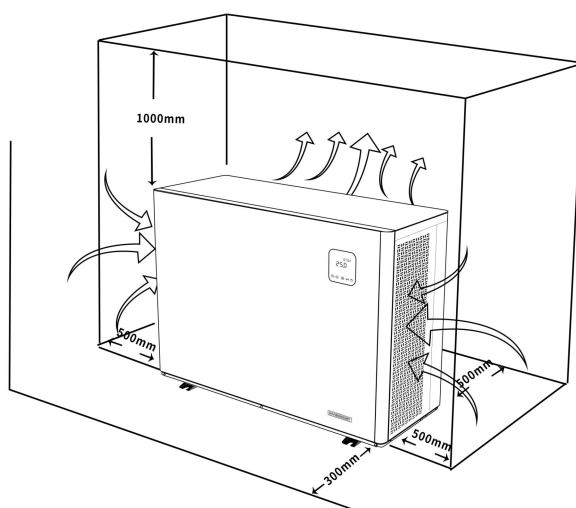

### 3.3 Distanza dalla piscina

La pompa di calore è normalmente installato all'interno di una zona perimetrale estendentesi 7,5 m dalla piscina. Maggiore è la distanza dalla piscina, maggiore è la perdita di calore nei tubi. Poiché i tubi sono principalmente sottoterra, la perdita di calore è basso per distanze fino a 30 m (15 m da e verso la pompa, 30 m in totale) a meno che il terreno è bagnato o il livello delle acque sotterranee è alto. Una stima approssimativa della perdita di calore per 30 ml è 0.6 kWh (2.000 BTU) per ogni differenza 5 ° C tra la temperatura dell'acqua in piscina e la temperatura del terreno circostante il tubo. Questo aumenta il tempo di funzionamento del 3% al 5%

### 3.4 Check-valvola installazione

Nota: Se viene utilizzato un apparecchio di dosaggio automatico per il cloro e acidità (pH), è essenziale per proteggere la pompa di calore contro concentrazioni chimiche eccessivamente alti che possono corrodere lo scambiatore di calore. Per questo motivo, le attrezzature di questo tipo deve essere sempre inserito nella tubazione sul lato a valle della pompa di calore, e si raccomanda di installare una valvola di ritegno per impedire un flusso inverso in assenza di circolazione dell'acqua.

I danni alla pompa di calore causati dalla mancata osservanza di questa indicazione non è coperto dalla garanzia.

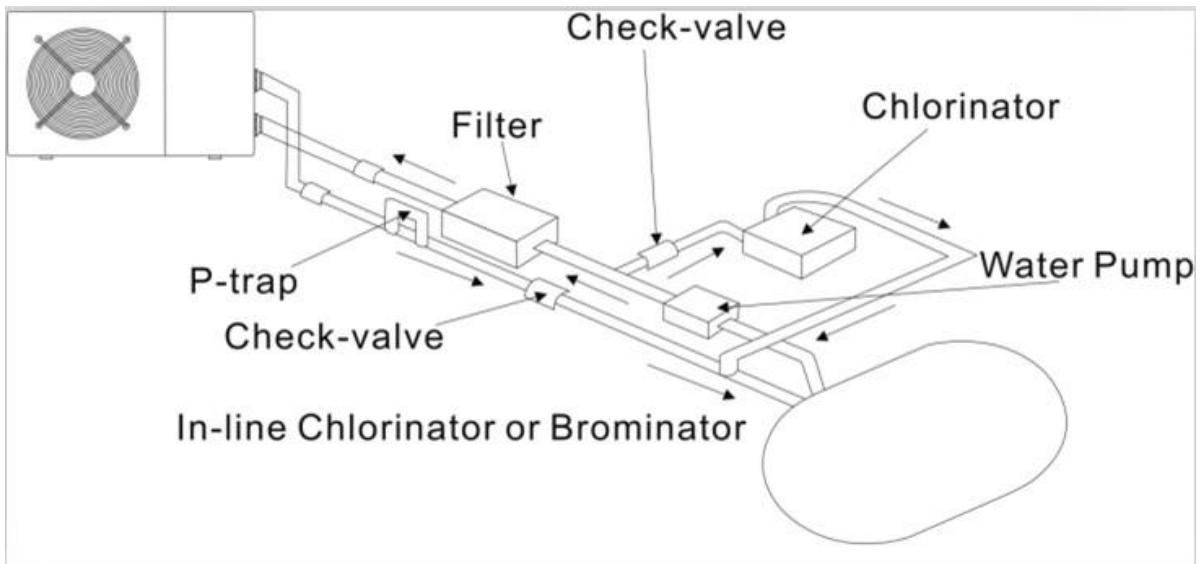

### 3.5 Disposizione tipica

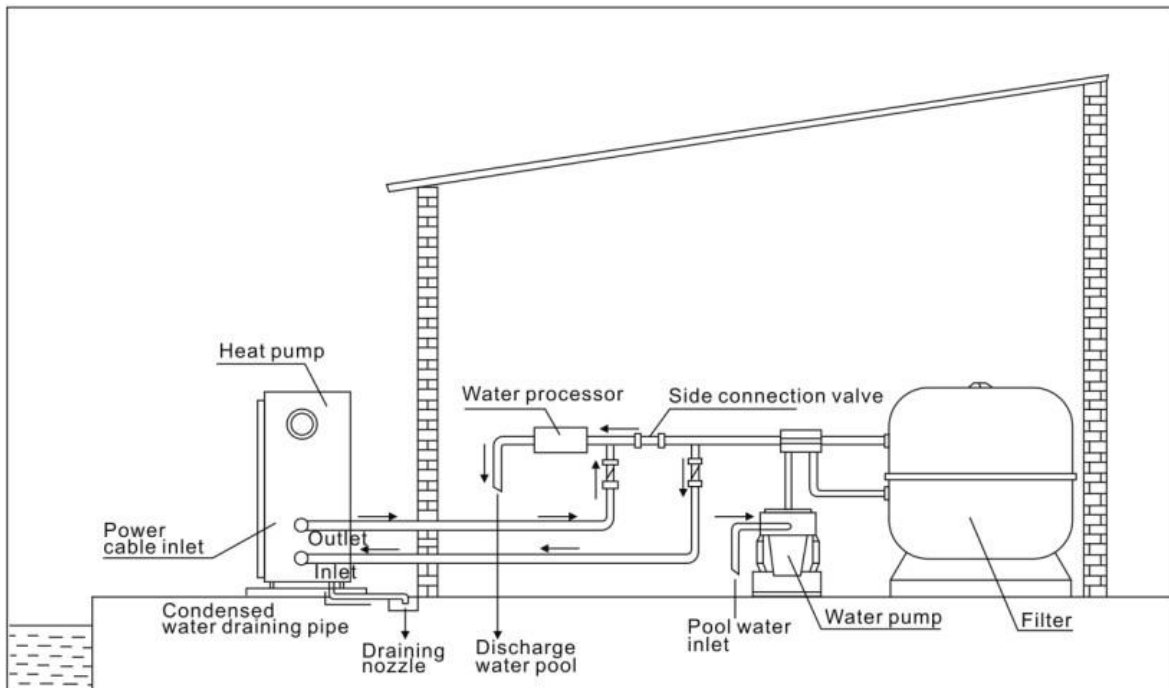

**Note:** Questa disposizione è solo un esempio illustrativo.

### 3.6 Operazione iniziale

**Nota:** Al fine di riscaldare l'acqua della piscina (o vasca idromassaggio), la pompa filtro deve essere in esecuzione per causare l'acqua a circolare attraverso la pompa di calore. La pompa di calore non si avvia se l'acqua non è in circolazione.

Dopo che tutti i collegamenti sono stati effettuati e controllati, eseguire la seguente procedura:

1. Accendere la pompa filtro. Controllare eventuali perdite e verificare che l'acqua scorre da e per la piscina.
2. Collegare l'alimentazione alla pompa di calore e premere il pulsante di accensione / spegnimento sul pannello di controllo elettronico. L'unità si avvia dopo l'intervallo di tempo scade (vedi sotto).
3. Dopo alcuni minuti, controllare se il soffiaggio dall'unità è più fresco.
4. Quando spegnere la pompa del filtro, l'unità dovrebbe spegnersi automaticamente, in caso contrario, quindi regolare

l'interruttore di flusso.

5. Lasciare la pompa di calore e la pompa filtro funzionano 24 ore al giorno fino al raggiungimento della temperatura desiderata. La pompa di calore interrotta a questo punto. Dopo di che, si riavvia automaticamente (fino a quando la pompa filtro è in funzione) ogni volta che la temperatura dell'acqua della piscina scende di 2 gradi al di sotto della temperatura impostata.

A seconda della temperatura iniziale dell'acqua in piscina e la temperatura dell'aria, può richiedere alcuni giorni per riscaldare l'acqua alla temperatura desiderata. Una buona copertura piscina può ridurre drasticamente la durata necessaria di tempo.

### **3.7 Condensazione**

L'aria aspirata nella pompa di calore è fortemente raffreddato dal funzionamento della pompa di calore per riscaldare l'acqua della piscina, che può causare la formazione di condensa sulle alette dell'evaporatore. La quantità di condensa può essere fino a diversi litri all'ora ad alta umidità relativa. Questo è talvolta erroneamente considerato come una perdita d'acqua.

## 4. Regolazione del bypass

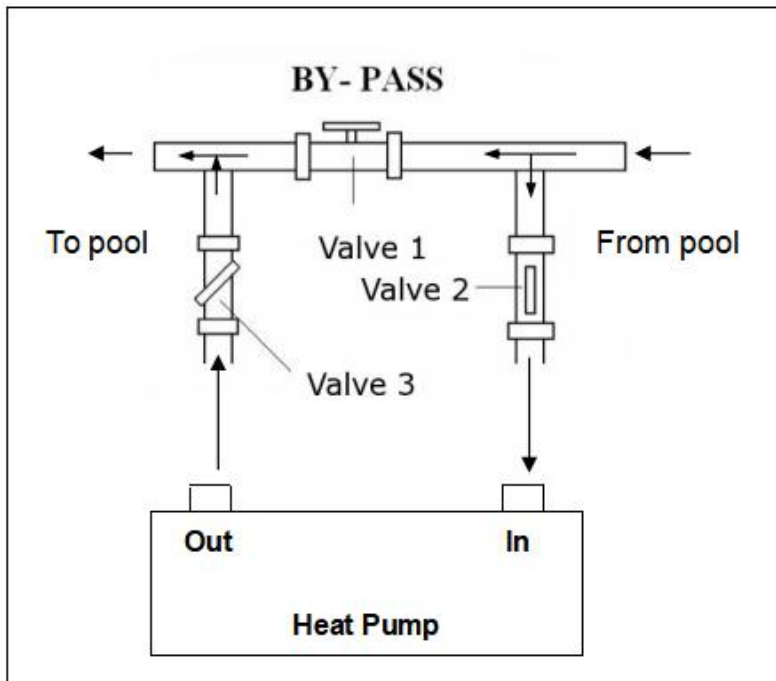

Utilizzare la seguente procedura per regolare il by-pass:

1. aprire completamente tutte tre valvole
2. lentamente chiudere la valvola 1 fino a quando la pressione dell'acqua è aumentata di circa 100 a 200 g
3. Chiudere la valvola 3 a circa metà per regolare la pressione del gas nel sistema di raffreddamento
4. Se il display visualizza il codice EE3 "ON" o di errore, vicino passo passo la valvola 2, per aumentare il flusso d'acqua e fermarsi quando il codice scompare.

Funzionamento ottimale della pompa di calore si verifica quando la pressione del gas di raffreddamento è  $22 \pm 2$  bar. Tale pressione può essere letta sul manometro vicino al pannello di controllo della pompa di calore. In queste condizioni il flusso d'acqua attraverso l'unità è anche ottimale.

**Nota: Funzionamento senza bypass o con regolazione bypass improprio può causare un funzionamento non ottimale della pompa di calore ed eventualmente danneggiarlo alla pompa di calore, che rende la garanzia nulla.**

### Flusso acqua:

Esso è dotato di un interruttore di flusso per proteggere l'unità HP esecuzione con adeguata portata d'acqua .E si accende quando la pompa funziona piscina e spegnerlo quando la pompa si spegne. Se il livello dell'acqua della piscina superiore a 1 m al di sopra o al di sotto manopola di regolazione automatica della pompa di calore, il rivenditore potrebbe dover aggiustare la sua messa in funzione.

**Ritardo** - La pompa di calore ha un built-in 3 minuti di ritardo di avviamento per proteggere il circolatorio e evitare l'eccessiva usura dei contatti. L'unità si riavvierà automaticamente dopo questo intervallo di tempo scade. Anche una breve interruzione di corrente si innesca questo ritardo e impedire che l'unità da riavviare immediatamente. Ulteriori interruzioni di alimentazione durante questo periodo di ritardo non influenzano la durata di 3 minuti del ritardo.

## 5. Visualizza Operazione di controllo

### 5.1. Guida operativa



Quando si collega la pompa di calore alla corrente, il display a LED mostra per 3 secondi un codice che indica il modello di pompa di calore.

### 5.2 I tasti e le loro funzioni

#### 5.2.1 Tasto



**Premere**  per avviare la pompa di calore, il display a LED mostra per 5 secondi la temperatura dell'acqua desiderata, quindi mostra la temperatura dell'acqua in entrata la modalità di funzionamento.

**Premere**  per arrestare la pompa di calore e mostrare "OFF"

Avvertenza: Nel corso della verifica e dell'impostazione dei parametri, premere il tasto  per uscire rapidamente e salvare le impostazioni correnti.

Premere nuovamente il tasto  per accendere/spegnere l'apparecchiatura.



#### 5.2.2 Premere il tasto



e il tasto



**Bloccare/Sbloccare il display:**



Tenere premuti per 5 secondi il tasto  e il tasto  per bloccare/sbloccare il display.

Il display si bloccherà automaticamente dopo 30 secondi di standby. (quando il display è bloccato l'icona "armadietto



" è accesa)

**Regolazione della temperatura dell'acqua:**

**Premere** il tasto  o il tasto  per regolare direttamente la temperatura dell'acqua.

Intervallo di impostazione della modalità di riscaldamento e della modalità automatica: 6-41 °C

Intervallo di impostazione della modalità di raffreddamento: 6-35 °C

### 5.2.3 Modalità di funzionamento del pulsante

Premere  per modificare la modalità di lavoro, Turbo, Smart e Silenzioso. La modalità predefinita è la modalità intelligente.

Mentre scegli il **Turbo**, la parola "**Turbo**" sarà accesa, la pompa di calore funzionerà solo in "Potenza massima".

Scegli lo **Smart**, si accenderà la scritta "**Smart**", la pompa di calore funzionerà in "Potenza media e massima".

Scegli il **Silent**, la parola "**Silent**" si accenderà, la pompa di calore funzionerà in "Potenza Media e Piccola".

### 5.2.4 Modalità pulsanti

Premere  per 5S per cambiare la modalità di riscaldamento  , la modalità di raffreddamento  e

la modalità automatica .

Nota: durante lo sbrinamento, il simbolo del riscaldamento lampeggia.

### Logica di funzionamento della modalità Automatica

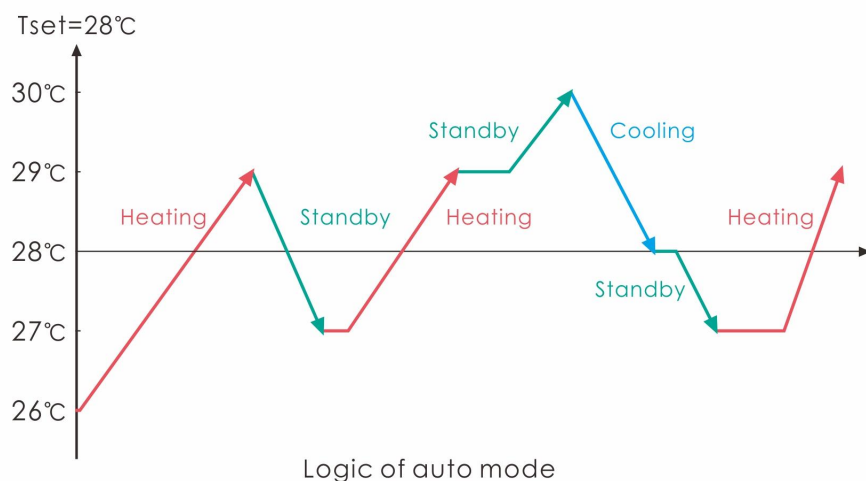

### 5.2.5 Verifica dei parametri:

Premere prima il tasto  , e poi premere il tasto  per verificare il parametro Utente da d0 a d14

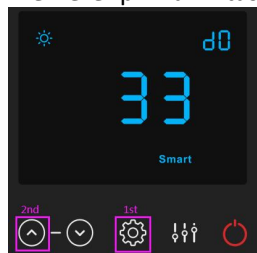

Codice	Condizione	Portata	Commento
d0	IPM temperatura dello stampo	0-120°C	Valore di test reale
d1	Temperatura dell'acqua in entrata T1	-9°C~99°C	Valore di test reale
d2	Temperatura dell'acqua in uscita T2	-9°C~99°C	Valore di test reale
d3	Temperatura ambiente T5	-30°C~70°C	Valore di test reale
d4	Codice di limitazione della frequenza	0,1,2,4,8,16	Valore di test reale
d5	Temperatura evaporatore T3	-30°C~70°C	Valore di test reale
d6	Temperatura scarico gas T6	0°C~C5°C (125°C)	Valore di test reale
d7	Passaggio di EEV	0~99	N*5
d8	Frequenza del funzionamento del compressore	0~99Hz	Valore di test reale
d9	Corrente del compressore	0~30A	Valore di test reale
d10	Velocità nominale delle ventola	0-1200 (rpm)	Valore di test reale
d11	Codice errore ultima volta	Tutto il codice i di errore	

**Commento: d4:Codice di limitazione della frequenza,**

**0: Nessun limite di frequenza;**

**1: Limite di temperatura del tubo della bobina;**

**2: Limite di frequenza di surriscaldamento o sovra raffreddamento;**

**4: Corrente limite di frequenza dell'unità;**

**8: Limite di frequenza della tensione di azionamento;**

**16: Limite di frequenza dell'alta temperatura di conduzione**

## 5.2.6 Impostazione dei parametri

**Premere** prima il tasto , quindi il tasto  per controllare/regolare il parametro Utente da P0 a P18, e

premere nuovamente  per accedere all'interfaccia di impostazione, in cui il parametro lampeggerà.

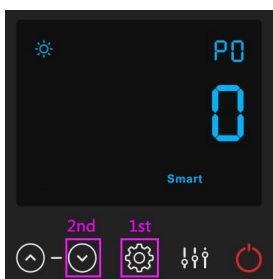





Codice	Nome	Portata	Default	Commento
P0	Sbrinamento obbligatorio	0-1	0	0: Funzionamento normale di default 1: sbrinamento obbligatorio.
P1	Modalità di funzionamento	0-1	1	1: Modalità riscaldamento, 0: modalità raffreddamento,
P2	Timer acceso/spento	0-1	0	1 il timer acceso/spento è in funzionamento, 0 il timer acceso/spento non è in funzione (l'impostazione P5 e P6 non funzionerà)
P3	Pompa dell'acqua	0-1	0	1: sempre in funzionamento; 0: dipende dal funzionamento del compressore
P4	Ora attuale	HH:MM	00: 00	<u>0-23:0-59</u>
P5	Timer attivato	HH:MM	00: 00	<u>0-23:0-59</u>
P6	Timer disattivato	HH:MM	00: 00	<u>0-23:0-59</u>
P7	Calibrazione temp acqua	-9~9	0	Impostazione di default: 0
P14	Ripristina le impostazioni di fabbrica	0-1	0	1-Ripristina le impostazioni di fabbrica, 0- default (ripristina P0, P1, P2, P3, P5, P6, P7, P8, P9, 10, P11 all'impostazione di fabbrica)
P16	Codice prodotto	/	/	Dipende dalla macchina
P18	Modalità	0-1	0	1 — Solo riscaldamento, 0 — Modalità Riscaldamento / Raffreddamento / Auto

Nota:

- 1). Premere a lungo  per 20 secondi per impostare P14, P16, P18.
- 2). I parametri P8, P9, P10, P11, P19, P20 sono solo per l'impostazione di fabbrica.

### 5.2.7

Simbolo di TIMER ON, la luce sarà accesa quando il valore di P2 è 1, il che significa che la funzione TIME ON & OFF è attiva. Quindi impostare l'ora corrente (parametro P4), TIMER ON (parametro P5) e TIMER OFF (parametro P6). Tutti i simboli (tranne il simbolo ) sul display saranno spenti quando il TIMER è OFF.

Nota: il simbolo  rimane acceso al riavvio della pompa di calore dopo TIME OFF, a meno che il valore di P2 non sia impostato a 0.

## 5.2.8 Funzione pilota di filtrazione del sistema

**Opzione 1; P3 = 0** La pompa di filtrazione è correlata all'avvio e all'arresto del funzionamento della pompa di calore.

La pompa di filtrazione inizia 60 secondi prima del compressore, la pompa di filtrazione inizia 30 secondi e quindi il flussostato dell'acqua rileva il flusso. Prima che la pompa di calore entri in modalità Standby, il compressore si arresta per primo e dopo 5 minuti si arresta la pompa di filtrazione.

	Condizione	Esempio	Logica di funzionamento della pompa dell'acqua	
Modalità riscaldamento	P3=0, T1≥Tset-0.5°C, durata di 30 minuti	P3=0, T1≥27.5°C, durata di 30 minuti	1. Quindi entra in modalità standby per 1 ora (non si riavvierà se non accendendolo manualmente).	2. Dopo 1 ora, la pompa di filtrazione si riavvierà per 5 minuti. Se T1≤27°C, la pompa di calore inizierà a funzionare fino a T1≥27.5°C e durerà per 30 minuti per andare in standby
Modalità raffreddamento	P3=0, T1≤Tset+0.5°C, durata di 30 minuti	P3=0, T1≤28.5°C, durata di 30 minuti	1. Quindi entra in modalità standby per 1 ora (non si riavvierà se non accendendolo manualmente).	2. Dopo 1 ora, la pompa di filtrazione si riavvierà per 5 minuti. Se verifica T1≥29°C, la pompa di calore inizierà a funzionare fino a T1≤28.5°C e durerà per 30 minuti per andare in standby

**Opzione 2; P3 = 1** La pompa di filtrazione è sempre attiva, P2 = 0 la funzione timer non è attiva

Nella condizione P3 = 1, quando T1≥Tset + 1°C (T1≥29°C) dura 3 minuti, la pompa di calore sarà in standby, mentre la pompa di filtrazione è sempre accesa.

Nell'opzione 2, con l'attivazione del timer; P2 = 1 per avviare e arrestare la pompa di filtrazione secondo la programmazione di P4 (tempo), P5 (timer ON) e P6 (timer OFF)

Se la pompa di calore viene accesa / spenta manualmente, la pompa di filtrazione si avvia e si arresta di conseguenza.

**Condizioni per l'avvio della pompa di calore, il timer ON agisce;**

Quando il timer raggiunge il tempo impostato di TIMER ON, la pompa di filtrazione si avvia e dopo 5 minuti si avvia la pompa di calore. La pompa di calore rimane ferma se l'acqua in temperatura è ≥ Tset + 1°C, prima che il TIMER sia SPENTO, la filtrazione è ancora attivata.

**Condizione per arrestare la pompa di calore, il timer OFF agisce;**

Quando il timer raggiunge il tempo impostato di TIMER OFF, la pompa di calore si arresta e dopo 5 minuti la pompa di filtrazione si arresta.

**Se la pompa di calore viene accesa / spenta manualmente, la pompa di filtrazione si avvia e si arresta di conseguenza.**

**NOTA:**

Tset = Temperatura dell'acqua impostata

Per esempio: Tset = 28°C Temperatura impostata dell'acqua nella pompa di calore della piscina

Tset-0.5 = 0.5°C in meno rispetto alla temperatura impostata. Tset- 0.5 = 28-0.5=27.5°C

Tset+0.5=0.5°C in più rispetto alla temperatura impostata. Tset+ 0.5 = 28+0.5=28.5°C

### 5.3 Logica di funzionamento del riscaldamento

Stato del funzionamento	Modalità di funzionamento	Acqua in temperatura -T1	Ad esempio, acqua in temperatura -T1	Livello di funzionamento della pompa di calore	
1	Avvio della pompa di calore	Quando si seleziona la "modalità di funzionamento Smart"	$T1 < Tset-1$	$T1 < 27^{\circ}C$	Modalità Powerful-frequenza F9
2			$Tset-1 \leq T1 < Tset$	$27^{\circ}C \leq T1 < 28^{\circ}C$	Frequenza: F9 -F8-F7,...,-F2
3			$Tset \leq T1 < Tset+1$	$28^{\circ}C \leq T1 < 29^{\circ}C$	Modalità Silent-frequenza F2
4		$T1 \geq Tset+1$	$T1 \leq 29^{\circ}C$	La pompa di calore rimarrà in modalità Standby, e non funzionerà fino a quando l'acqua non scende sotto i 28°C.	
5		Quando si seleziona la "modalità di funzionamento Silent"	$T1 < Tset$	$T1 < 28^{\circ}C$	Modalità Smart-frequenza F5.
6			$Tset \leq T1 < Tset+1$	$28^{\circ}C \leq T1 < 29^{\circ}C$	Modalità Silent-frequenza F2/F1.
7			$T1 \geq Tset+1$	$T1 \geq 29^{\circ}C$	La pompa di calore rimarrà in modalità Standby, e non funzionerà fino a quando l'acqua non scende sotto i 28°C.
8		Quando si seleziona la "modalità di funzionamento Powerful"	$T1 < Tset+1$	$T1 < 29^{\circ}C$	Modalità Powerful-frequenza F10/F9
9			$T1 \geq Tset+1$	$T1 \geq 29^{\circ}C$	La pompa di calore rimarrà in modalità Standby, e non funzionerà fino a quando l'acqua non scende sotto i 28°C.
10	Riavvio per riscaldare l'acqua nello stato di stand-by	Quando la pompa di calore funziona in "Modalità Smart"	$T1 \geq Tset$	$T1 \geq 28^{\circ}C$	Standby
11			$Tset > T1 \geq Tset-1$	$28^{\circ}C > T1 \geq 27^{\circ}C$	Silent-frequenza F2
12			$Tset-1 > T1 \geq Tset-2$	$27^{\circ}C > T1 \geq 26^{\circ}C$	Frequenza: F2 -F3-F4,...,-F9
13			$T1 < Tset-2$	$T1 < 26^{\circ}C$	Powerful-frequenza F9
14		Quando la pompa di calore funziona in "Modalità Silent"	$T1 \geq Tset$	$T1 \geq 28^{\circ}C$	Standby
15			$Tset > T1 \geq Tset-1$	$28^{\circ}C > T1 \geq 27^{\circ}C$	Modalità Silent-frequenza F2/F1
16			$T1 < Tset-1$	$T1 < 27^{\circ}C$	Smart-frequenza F5
17	Quando la pompa di calore funziona in "Modalità Powerful"	$T1 < Tset-1$	$T1 < 27^{\circ}C$	Powerful-frequenza F10/F9	

## 5.4 Logica di funzionamento del raffreddamento

Stato del funzionamento	Modalità di funzionamento	Acqua in temperatura -T1	Ad esempio, acqua in temperatura -T1	Livello di funzionamento della pompa di calore		
1	Avvio della pompa di calore	Quando si seleziona la "modalità di funzionamento Smart"	$T1 \leq T_{set}-1$	$T1 \leq 27^{\circ}\text{C}$	Standby.	
2			$T_{set}-1 < T1 \leq T_{set}$	$27^{\circ} < T1 \leq 28^{\circ}\text{C}$	Modalità Silent-frequenza F2	
3			$T_{set} < T1 \leq T_{set}+1$	$28 < T1 \leq 29^{\circ}\text{C}$	Frequenza: F9 -F8-F7,...,- F2	
4			$T1 \geq T_{set}+1$	$T1 \geq 29^{\circ}\text{C}$	Modalità Powerful-frequenza -F9	
5	Avvio della pompa di calore	Quando si seleziona la "modalità di funzionamento Silent"	$T1 \leq T_{set}-1$	$\leq 27^{\circ}\text{C}$	Standby	
6			$T_{set}-1 < T1 \leq T_{set}$	$27^{\circ}\text{C} < T1 \leq 28^{\circ}\text{C}$	Modalità Silent-frequenza F2/F1	
7			$T1 > T_{set}$	$T1 > 28^{\circ}\text{C}$	Modalità Smart-frequenza F5	
8	Avvio della pompa di calore	Quando si seleziona la "modalità di funzionamento Powerful"	$T1 > T_{set}-1$	$T1 > 27^{\circ}\text{C}$	Modalità Powerful-frequenza F10/F9	
9			$T1 \leq T_{set}-1$	$T1 \leq 27^{\circ}\text{C}$	Standby	
10	Riavvio per raffreddare l'acqua nello stato di Stand-by	Smart	$T1 \leq T_{set}-1$	$T1 \leq 27^{\circ}\text{C}$	Standby	
11			$T_{set} \leq T1 < T_{set}+1$	$28 \leq T1 < 29^{\circ}\text{C}$	Silent-frequenza F2	
12			$T_{set}+1 \leq T1 < T_{set}+2$	$29 \leq T1 < 30^{\circ}\text{C}$	Frequenza: F2 -F3-F4,...,- F9	
13			$T1 \geq T_{set}+2$	$T1 \geq 30^{\circ}\text{C}$	Modalità Powerful-frequenza F9	
14		Silent		$T_{set} < T1 \leq T_{set}+1$	$28 < T1 \leq 29^{\circ}\text{C}$	Modalità Silent-frequenza F2/F1
15				$T1 > T_{set}+1$	$T1 > 29^{\circ}\text{C}$	Modalità Smart-frequenza F5
16		Powerful		$T1 > T_{set}+1$	$T1 > 29^{\circ}\text{C}$	Modalità Powerful-frequenza F10/F9
17	$T1 \leq T_{set}-1$			$T1 \leq 27^{\circ}\text{C}$	Standby	

## 6. Risoluzione dei problemi

### 6.1 Visualizzazione del codice di errore sul controller LED

Problema	Codice	Causa	Soluzione
Errore della sonda di temperatura dell'acqua in entrata d1-TH6	PP01	3. Sonda in circuito aperto o in corto circuito 4. Il cablaggio della sonda è allentato	1. Verificare o sostituire la sonda 2. Riparare il cablaggio delle sonde
Errore della sonda di temperatura dell'acqua in uscita d2-TH5	PP02	1. Sonda in circuito aperto o in corto circuito 2. Il cablaggio della sonda è allentato	1. Verificare o sostituire la sonda 2. Riparare il cablaggio delle sonde
Errore della sonda dell'evaporatore d5-TH2	PP03	1. Sonda in circuito aperto o in corto circuito 2. Il cablaggio della sonda è allentato	1. Verificare o sostituire la sonda 2. Riparare il cablaggio delle sonde
Errore della sonda di temperatura ambiente d3-TH1	PP05	1. Sonda in circuito aperto o in corto circuito 2. Il cablaggio della sonda è allentato	1. Verificare o sostituire la sonda 2. Riparare il cablaggio delle sonde
Errore della sonda di tuberia di aspirazione del compressore d6-TH3	PP06	1. Sonda in circuito aperto o in corto circuito 2. Il cablaggio della sonda è allentato	1. Verificare o sostituire la sonda 2. Riparare il cablaggio delle sonde
Protezione antigelo in inverno	PP07	La temperatura ambiente o dell'acqua in entrata è troppo bassa	Protezione normale
Protezione per bassa temperatura ambiente	PP08	1. L'ambiente è al di fuori dell'ambito di uso 2. Anomalia della sonda	1. Smettere di utilizzare fuori dall'ambito di uso 2. Sostituire la sonda.
Temperatura del condensatore. Eccessiva in modalità raffreddamento d5-TH2	PP10	2. Temperatura ambiente o temperatura dell'acqua troppo elevata in modalità raffreddamento 2. Il sistema refrigerante è anomalo	2. Verificare l'ambito di utilizzo 2. Verificare il sistema refrigerante
Protezione per temperatura dell'acqua. Molto bassa in modalità raffreddamento d2-TH5	PP11	1. Portata d'acqua ridotta 2. Anomalia della sonda di temperatura d2-TH5	2. Verificare la pompa di filtrazione e il circuito dell'acqua 3. Sostituire la sonda di temperatura d2-TH5
Errore di alta pressione TS4	EE01	1. La temperatura ambiente è troppo alta il mini-pressostato di alta pressione non è ben collegato o è guasto. 2. La temperatura dell'acqua è troppo alta 3. La portata dell'acqua è insufficiente. 4. La velocità della ventola è anomala o il motoventilatore ha subito dei danni	1. Verificare il cablaggio del mini-pressostato di alta pressione o sostituirlo. 2. Controllare il motoventilatore 3. Verificare e riparare il sistema di tubazioni

<b>Problema</b>	<b>Codice</b>	<b>Causa</b>	<b>Soluzione</b>
Errore di bassa pressione TS5	EE02	<ol style="list-style-type: none"> <li>1. Il mini-pressostato di bassa pressione non è ben collegato o è guasto. si è bloccato o il sistema di tubazioni è otturato</li> <li>2. La velocità del motore è anomala o il motore è danneggiato</li> <li>3. Fuga di gas</li> </ol>	<ol style="list-style-type: none"> <li>1. Verificare l'EEV e il sistema di tubazioni Verificare il motore</li> <li>2. Attraverso il manometro di alta pressione per verificare il valore della pressione</li> <li>3. Verificare il sistema refrigerante</li> </ol>
Errore nella portata dell'acqua TS1	EE03 Or "ON"	<ol style="list-style-type: none"> <li>1. Il flussostato dell'acqua non è ben collegato o è danneggiato</li> <li>2. Portata dell'acqua assente/insufficiente.</li> </ol>	<ol style="list-style-type: none"> <li>1. Verificare il cablaggio del flussostato dell'acqua o sostituirlo</li> <li>2. Verificare la pompa di filtrazione o il circuito dell'acqua</li> </ol>
Protezione da surriscaldamento della la temperatura dell'acqua (d2-TH5) in modalità riscaldamento	EE04	<ol style="list-style-type: none"> <li>1. Portata dell'acqua ridotta</li> <li>2. Il flussostato dell'acqua è bloccato e la fornitura d'acqua è stata interrotta</li> <li>3. Anomalia della sonda d2-TH5</li> </ol>	<ol style="list-style-type: none"> <li>1. Verificare il circuito dell'acqua</li> <li>2. Controllare la pompa di filtrazione o il flussostato dell'acqua</li> <li>3. Controllare la sonda d2-TH5 o sostituirla</li> </ol>
Temperatura di scarico del compressore troppo alta d6-TH3	EE05	<ol style="list-style-type: none"> <li>1. Mancanza di gas</li> <li>2. Portata dell'acqua ridotta</li> <li>3. Il sistema di tubazioni è bloccato</li> <li>4. Guasto della sonda d6-TH3</li> </ol>	<ol style="list-style-type: none"> <li>1. Controllare il manometro di alta pressione, se ha un livello insufficiente aggiungere gas</li> <li>2. Verificare il circuito dell'acqua e la pompa di filtrazione</li> <li>3. Verificare il sistema di tubazioni per vedere se esistono ostruzioni</li> <li>4. Sostituire la sonda d6-TH3</li> </ol>
Errore del controller	EE06	<ol style="list-style-type: none"> <li>1. La connessione del cavo non è corretta, o il cavo di segnale è danneggiato</li> <li>2. Guasto del controller</li> </ol>	<ol style="list-style-type: none"> <li>1. Controllare e ricollegare il cavo di segnale</li> <li>2. Sostituire il cavo di segnale</li> <li>3. Interrompere l'alimentazione e riavviare la pompa</li> <li>4. Sostituire il controller</li> </ol>
Protezione del consumo del compressore	EE07	<ol style="list-style-type: none"> <li>1. La corrente del compressore è eccessiva istantaneamente</li> <li>2. Connessione errata per la sequenza di fase del compressore</li> <li>3. Accumuli di liquidi e olio nel compressore fanno aumentare la corrente</li> <li>4. Compressore o scheda madre danneggiati</li> <li>5. Portata dell'acqua anomala</li> <li>6. Fluttuazioni di corrente in poco tempo</li> </ol>	<ol style="list-style-type: none"> <li>1. Verificare il compressore e le fasi.</li> <li>2. Verificare che la potenza sia nella norma</li> <li>3. Verificare il collegamento della sequenza di fase</li> <li>4. Verificare il circuito dell'acqua dell'acqua e la pompa di filtrazione</li> <li>5. Verificare la principale fonte di energia</li> </ol>

<b>Problema</b>	<b>Codice</b>	<b>Causa</b>	<b>Soluzione</b>
Errore di comunicazione tra il controller e la scheda principale	EE08	1. Collegamento del cavo di segnale debole o cavo di segnale danneggiato 2. Guasto del controller	1. Controllare e ricollegare il cavo di segnale 2. Sostituire il cavo di segnale 3. Interrompere l'alimentazione elettrica e riavviare la pompa 4. Sostituire il controller
Errore di comunicazione tra la scheda principale e la scheda del driver	EE09	1. Collegamento del cavo di comunicazioni debole 2. Il cavo è danneggiato	1. Verificare il collegamento del cavo 2. Sostituire il cavo
Protezione VDC. Tensione eccessiva	EE10	1. La tensione della linea della scheda madre è troppo alta 2. Il controller è danneggiato	1. Verificare che la potenza rientri nell'intervallo normale 2. Sostituire il controller
Protezione modulo IPM	EE11	1. Errore di dati 2. Errata connessione di fase del compressore 3. Un accumulo di liquidi o olio nel compressore fanno aumentare la corrente 4. Compressore o controller danneggiati	1. Errore di programma, spegnere l'alimentazione e riavviare dopo 3 minuti 2. Verificare la connessione di sequenza del compressore 3. Controllare la pressione del sistema tramite manometro 4. Controllare se la temperatura ambiente e dell'acqua sono troppo alte 5. Cambia una nuova scheda driver
Protezione di bassa tensione di VDC	EE12	1. La tensione della tensione madre è troppo bassa 2. Il controller è danneggiato	1. Verificare se la potenza rientra nell'intervallo normale 2. Sostituire la scheda di controllo
Protezione contro sovrintensità	EE13	1. La corrente del compressore è momentaneamente eccessiva 2. Anomalia nella portata dell'acqua 3. Fluttuazione di energia in poco tempo 4. Errato induttore PFC	1. Verificare il compressore 2. Verificare il sistema di tubazioni 3. Verificare che la potenza rientri nell'intervallo normale 4. Verificare che si stia utilizzando l'induttore PFC corretto
Errore di uscita del circuito di rilevamento della temperatura del modulo IPM	EE14	1. Uscita fuori dalla norma del circuito termico del modulo IPM 2. Anomalia o guasto del motoventilatore 3. Pala della ventola rotta	1. Sostituire il controller 2. Verificare se la velocità del motore è troppo bassa e se il motoventilatore è danneggiato, eventualmente sostituirlo 3. Sostituire la pala della ventola 4. Verificare la tensione di ingresso
Protezione della temperatura alta del modulo IPM	EE15	1. Eccezione di uscita del circuito termico del modulo IPM 2. Il motore è anormale o danneggiato 3. Pala della ventola rotta	1. Sostituire il controller 2. Verificare se la velocità del motore del ventilatore è insufficiente o se il motoventilatore è danneggiato, sostituirlo 3. Sostituire la pala della ventola

<b>Problema</b>	<b>Codice</b>	<b>Causa</b>	<b>Soluzione</b>
Protezione del modulo PFC	EE16	<ol style="list-style-type: none"> <li>1. Eccezione di uscita del modulo PFC</li> <li>2. Anomalia o danno del motore</li> <li>3. La pala della ventola rotta</li> <li>4. Salto nel voltaggio di ingresso, anomalia della potenza di ingresso</li> </ol>	<ol style="list-style-type: none"> <li>1. Sostituire il controller</li> <li>2. Verificare se la velocità del motore è insufficiente o il motoventilatore è danneggiato, eventualmente sostituirlo</li> <li>3. Sostituire la pala della ventola</li> <li>4. Verificare la tensione di ingresso</li> </ol>
Guasto motore ventilatore DC	EE17	<ol style="list-style-type: none"> <li>1. Il motore CC è danneggiato</li> <li>2. Per la macchina trifase, verificare se il neutro è collegato</li> <li>3. La scheda madre è danneggiata</li> <li>4. La pala della ventola è bloccata</li> </ol>	<ol style="list-style-type: none"> <li>1. Individuare il motore DC e sostituirlo</li> <li>2. Controllare il collegamento del cablaggio per la macchina trifase</li> <li>2. Controllare la scheda, sostituire una nuova scheda del driver del motore del ventilatore o la scheda principale in caso di guasto</li> <li>3. Individuare l'ostacolo ed eliminarlo</li> </ol>
Anomalia nel funzionamento del modulo PFC	EE18	La scheda di controllo è danneggiata	<ol style="list-style-type: none"> <li>1. Sostituire il controller</li> <li>2. Verificare se la velocità del motore del ventilatore è insufficiente o il motoventilatore è danneggiato, eventualmente sostituirlo</li> </ol>
Errore per alta temperatura del modulo PFC	EE19	<ol style="list-style-type: none"> <li>1. Anomalia nell'uscita del circuito termico del modulo PFC</li> <li>2. Anomalia o danno nel motore</li> <li>3. Pala della ventola rotta</li> <li>4. Vite della scheda di controllo allenata</li> </ol>	<ol style="list-style-type: none"> <li>1. Sostituire il controller</li> <li>2. Controllare se la velocità del motore è troppo bassa o il motore del ventilatore è danneggiato, eventualmente sostituirlo</li> <li>3. Sostituire la pala della ventola</li> <li>4. Verificare che la vite non sia allenata</li> </ol>
Errore nell'alimentazione di ingresso	EE20	Il voltaggio della sorgente di alimentazione oscilla eccessivamente	Verificare la stabilità del voltaggio
Errore nel controllo del software	EE21	<ol style="list-style-type: none"> <li>2. Il compressore va fuori giri</li> <li>2. Programma errato</li> <li>3. Delle impurità all'interno del compressore causano una velocità di rotazione instabile</li> </ol>	<ol style="list-style-type: none"> <li>2. Verificare o sostituire il controller</li> <li>2. Inserire il programma corretto</li> </ol>



<b>Problema</b>	<b>Codice</b>	<b>Causa</b>	<b>Soluzione</b>
Errore di circuito nel rilevamento della corrente	EE22	<ul style="list-style-type: none"> <li>2. Segnale di tensione anomalo</li> <li>3. Controller danneggiato</li> <li>4. Errore della scheda madre</li> </ul>	<ul style="list-style-type: none"> <li>1. Verificare o sostituire il controller</li> <li>2. Cambia una nuova scheda driver</li> </ul>
Errore all'avvio del compressore	EE23	<ul style="list-style-type: none"> <li>4. Il controller è danneggiato</li> <li>5. Errore nel cablaggio del compressore , scarso contatto o mancato collegamento</li> <li>6. Accumulo di liquido all'interno</li> <li>4. Errata connessione di fase per il compressore</li> </ul>	<ul style="list-style-type: none"> <li>1. Verificare o sostituire il controller</li> <li>2. Verificare il cablaggio del compressore secondo lo schema elettrico</li> <li>3. Controllare il compressore o sostituirlo</li> </ul>
Errore del dispositivo di temperatura ambiente nella scheda elettronica	EE24	Errore del dispositivo di temperatura ambiente	Sostituire la scheda del controller o la scheda principale
Errore nella fase del compressore	EE25	Connessione scadente delle fasi U,V e W	Verificare l'attuale cablaggio confrontandolo con lo schema elettrico
Errore della valvola a 4 vie	EE26	<ul style="list-style-type: none"> <li>2. Errore della valvola di ritorno a 4 vie</li> <li>2. Mancanza di refrigerante (non la rileva in caso di d5-TH2 o d3-TH1)</li> </ul>	<ul style="list-style-type: none"> <li>3. Passare alla modalità raffreddamento per verificare se la valvola a 4 vie si è invertita correttamente</li> <li>4. Sostituire la valvola a 4 vie</li> <li>3. Caricare gas</li> </ul>
Errore di lettura dei dati sulla EEPROM	EE27	<ul style="list-style-type: none"> <li>2. Dati EEPROM errati nel programma o errore di inserimento dei dati EEPROM</li> <li>2. Errore della scheda principale</li> </ul>	<ul style="list-style-type: none"> <li>2. Inserire i dati corretti EEPROM</li> <li>2. Sostituire il controller</li> </ul>
Errore di comunicazione nel chip interno della scheda elettronica	EE28	Errore della scheda principale	<ul style="list-style-type: none"> <li>2. Spegnerne l'alimentazione elettrica e riavviare</li> <li>2. Sostituire la scheda principale</li> </ul>

**Commenti:**

1. In modalità riscaldamento, se la temperatura dell'acqua in uscita è più elevata rispetto alla temperatura impostata di oltre 7°C, il controller LED mostra un errore EE04 per protezione da surriscaldamento dell'acqua.

In modalità raffreddamento, se la temperatura dell'acqua in uscita è più bassa rispetto alla temperatura impostata di oltre 7°C, il controller LED mostra un errore PP11 per protezione da sovraraffreddamento dell'acqua.

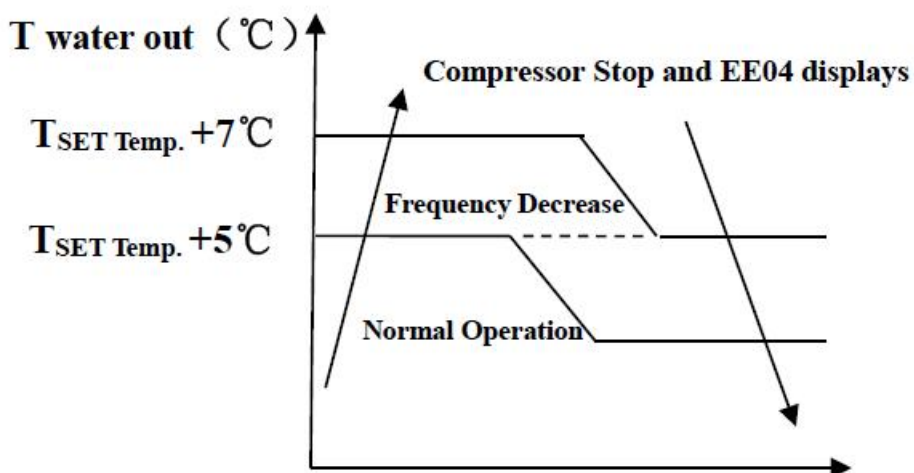

**EE04 Protezione da surriscaldamento dell'acqua in uscita**

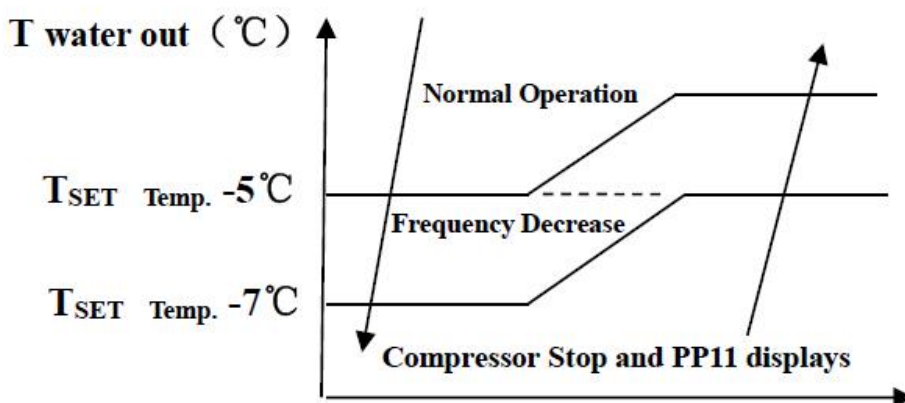

**PP11 Protezione da sovra raffreddamento dell'acqua in uscita**

Per un esempio si veda a seguire:

Modalità	Temperatura acqua in uscita	Impostazione temperatura	Condizione	Errore
Modalità riscaldamento	36°C	29°C	$T_{out} - T_{set} \geq 7^{\circ}\text{C}$	EE04 Protezione da surriscaldamento per temperatura dell'acqua (d2-TH5)
Modalità raffreddamento	23°C	30°C	$T_{set} - T_{out} \geq 7^{\circ}\text{C}$	PP11 Protezione insufficiente per temperatura dell'acqua (d2-TH5)

## 6.2 Altri guasti e soluzioni (non viene mostrato nulla sul controller LED)

Problema	Si Osserva	Causa	Soluzione
Pompa di calore non funzionante	Non viene mostrato nulla sul controller LED	Nessuna alimentazione	Verificare che il cavo e l'interruttore siano collegati
	Il controller LED mostra il tempo attuale.	Pompa di calore in modalità stand-by	Avviare la pompa di calore per metterla in funzione
	Il controller LED wire mostra l'attuale temperatura dell'acqua.	<ol style="list-style-type: none"> <li>1. La temperatura dell'acqua sta raggiungendo il valore impostato, pompa di calore in modalità di temperatura costante.</li> <li>2. La pompa di calore ha appena iniziato a funzionare.</li> <li>3. In fase di sbrinamento.</li> </ol>	<ol style="list-style-type: none"> <li>1. Verificare l'impostazione della temperatura dell'acqua.</li> <li>2. Avviare la pompa di calore dopo alcuni minuti.</li> <li>3. Il controller LED deve mostrare "Sbrinamento".</li> </ol>
La temperatura dell'acqua si raffredda mentre la pompa di calore funziona in modalità riscaldamento	Il controller LED mostra l'attuale temperatura dell'acqua e il codice errore	<ol style="list-style-type: none"> <li>1. È stata scelta la modalità sbagliata.</li> <li>2. Le cifre mostrano i problemi.</li> <li>3. Guasto del controller.</li> </ol>	<ol style="list-style-type: none"> <li>1. Regolare la modalità per un adeguato funzionamento</li> <li>2. sostituire il controller LED difettoso, e verificare lo stato dopo aver cambiato modalità di funzionamento, controllando la temperatura dell'acqua in entrata e in uscita.</li> <li>3. Sostituire o riparare la pompa di calore</li> </ol>
Breve funzionamento	Il controller LED mostra l'attuale temperatura dell'acqua, non appare il codice di errore	<ol style="list-style-type: none"> <li>1. Ventilatore NON funzionante.</li> <li>2. La ventilazione dell'aria non è sufficiente.</li> <li>3. Il refrigerante non è sufficiente.</li> </ol>	<ol style="list-style-type: none"> <li>1. Verificare le connessioni dei cavi tra motore e ventilatore, se necessario, sostituire.</li> <li>2. Verificare la posizione della pompa di calore, ed eliminare tutti gli ostacoli che impediscono una buona circolazione dell'aria.</li> <li>3 Sostituire o riparare la pompa di calore.</li> </ol>
Macchie di acqua	Macchie d'acqua sulla pompa di calore	<ol style="list-style-type: none"> <li>1. Protezione</li> <li>2. Perdita d'acqua.</li> </ol>	<ol style="list-style-type: none"> <li>1. Nessuna azione.</li> <li>2. Controllare con attenzione lo scambiatore di calore in titanio per escludere eventuali fughe</li> </ol>
Eccesso di ghiaccio nell'evaporatore	Eccesso di ghiaccio nell'evaporatore		<ol style="list-style-type: none"> <li>1. Verificare la posizione della pompa di calore, ed eliminare tutti gli ostacoli che impediscono una buona circolazione dell'aria.</li> <li>2. Sostituire o riparare la pompa di calore.</li> </ol>



I-3051S \* The dotted line part are only used in some models

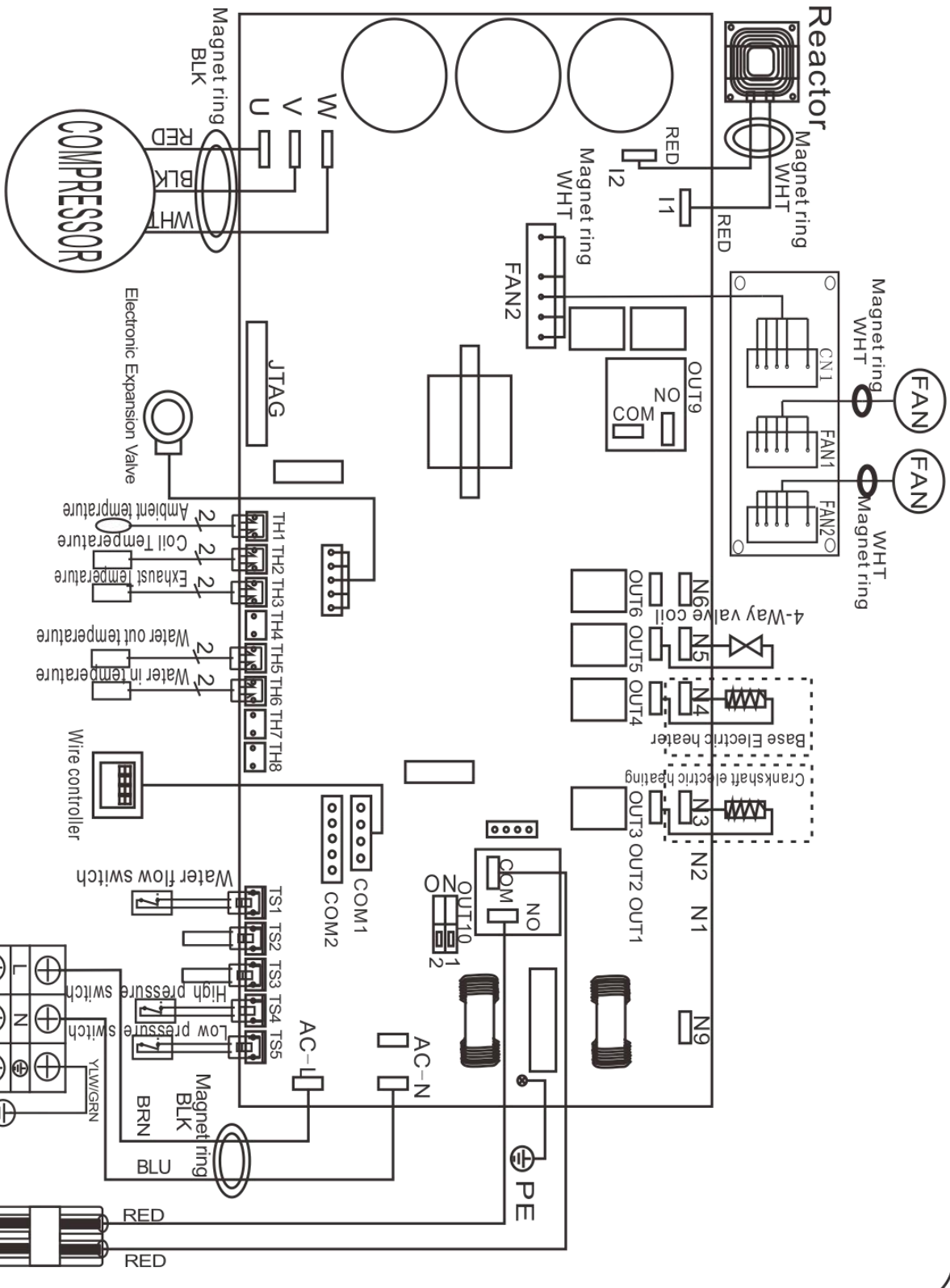

Power Supply  
220V-240V~50HZ

SWITCH  
(Water Pump)

I-5101

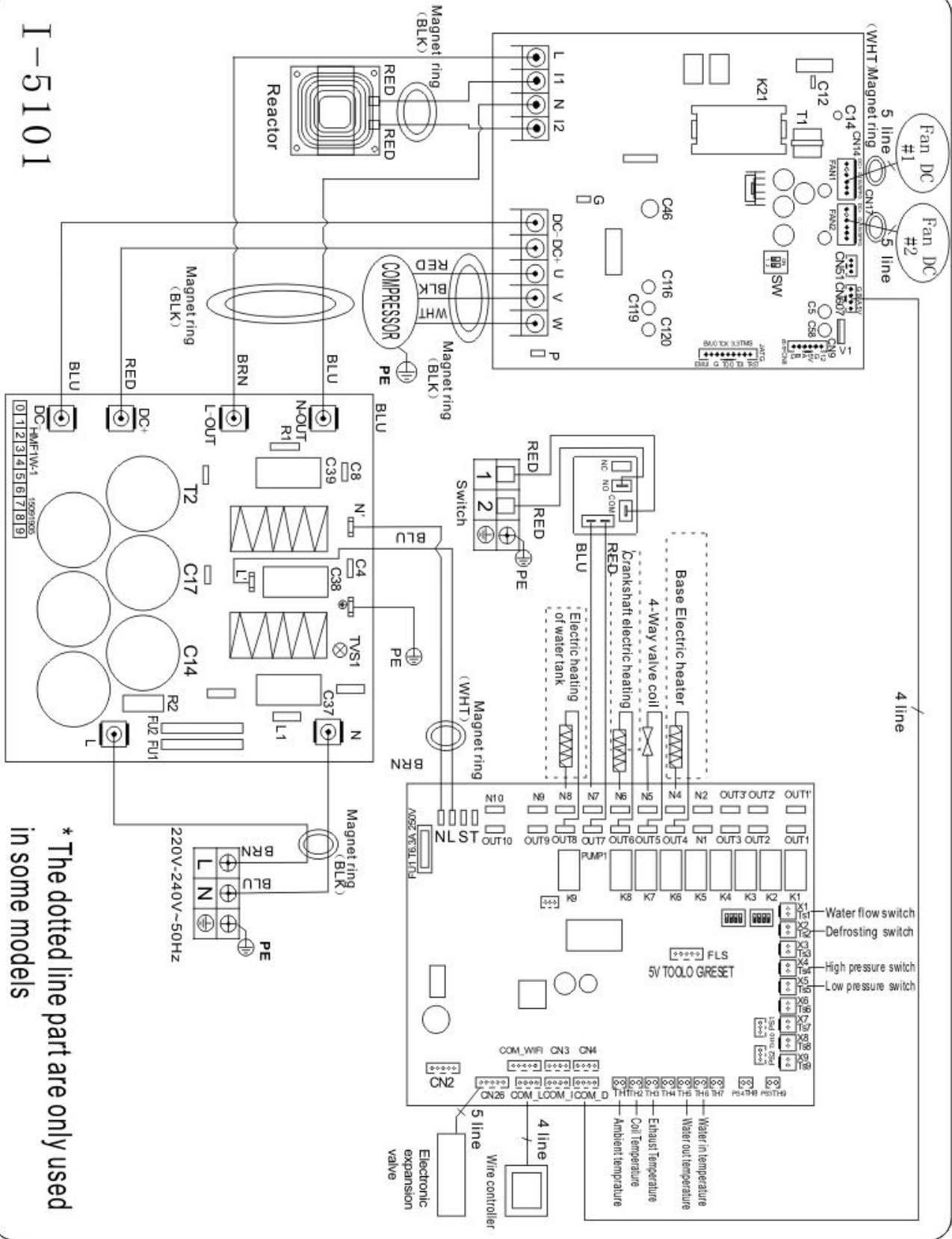

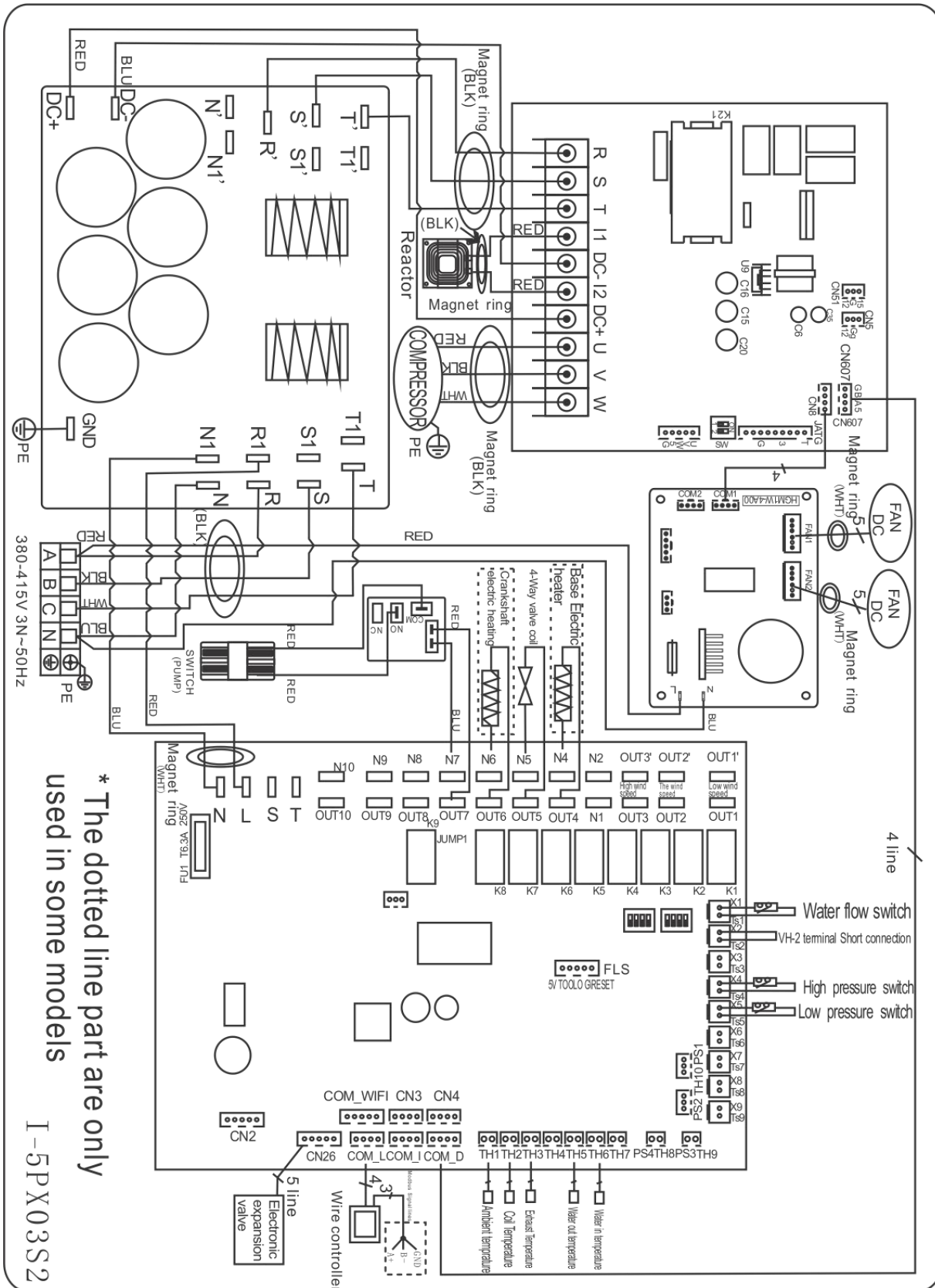

**NOTA:**

- (1) Sopra lo schema elettrico solo per riferimento, si prega di sottoporre la macchina a pubblicare lo schema elettrico.
- (2) La pompa di calore della piscina deve essere collegata bene con il filo di terra, sebbene lo scambiatore di calore dell'unità sia elettricamente isolato dal resto dell'unità. È comunque necessario mettere a terra l'unità per proteggerci dai cortocircuiti all'interno dell'unità. .

**Disconnessione:** un dispositivo di disconnessione (interruttore di circuito, interruttore con fusibile o senza fusibile) deve essere posizionato in vista e facilmente accessibile dall'unità. Questa è una pratica comune sulle pompe di calore commerciali e residenziali. Impedisce l'eccitazione a distanza di apparecchiature non presidiate e consente di disattivare l'alimentazione dell'unità durante la manutenzione dell'unità.

## 8. Manutenzione

- (1) Controllare con regolarità il sistema di erogazione dell'acqua per evitare che entri aria nel sistema con una conseguente riduzione della portata dell'acqua, Tali guasti comprometterebbero la performance e l'affidabilità della pompa di calore.
- (2) Pulire con regolarità le piscine e i sistemi filtranti per evitare di causare danni all'unità dovuti alla sporcizia presente nell'impianto di filtrazione.
- (3) Conservare la pompa di calore sempre asciutta, ben ventilata e pulita sul lato dello scambiatore di calore in modo tale da consentire uno scambio di calore senza problemi e un buon risparmio energetico.
- (4) Solo un tecnico qualificato è autorizzato a intervenire sulla pressione del sistema di refrigerazione.
- (5) Verificare la connessione del cavo di potenza. Se la pompa di calore inizia a funzionare in maniera anomala, spegnerla e contattare un tecnico qualificato.
- (6) Svuotare sempre l'acqua presente nella pompa di calore quando la medesima rimane ferma, ovvero in inverno o quando la temperatura ambiente scende sotto lo 0°C. Altrimenti, si corre il rischio di congelamento nello scambiatore in titanio con un conseguente annullamento della garanzia.



# 9. Esploso

UX11Csi32/UX14Csi32

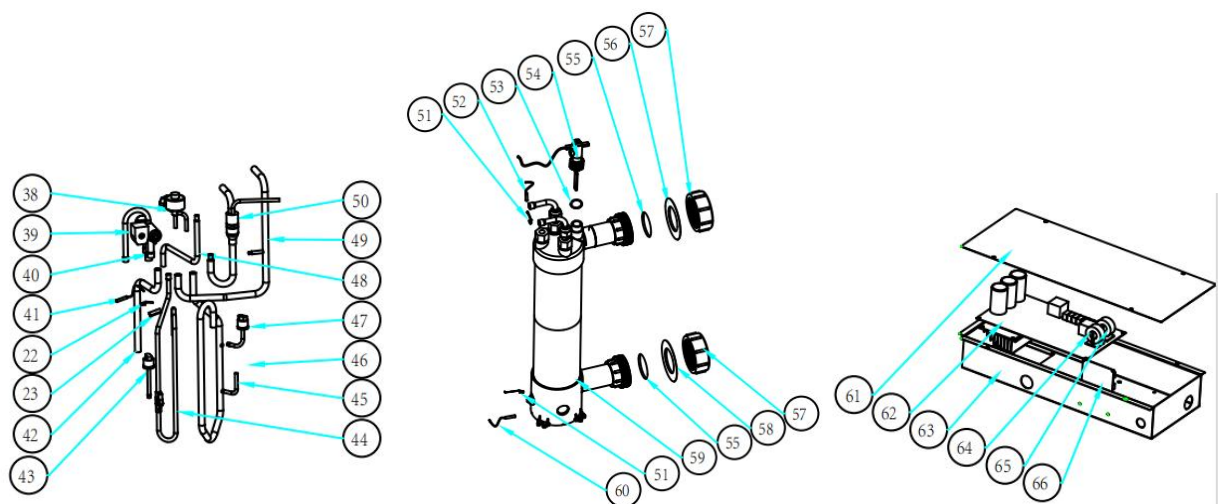
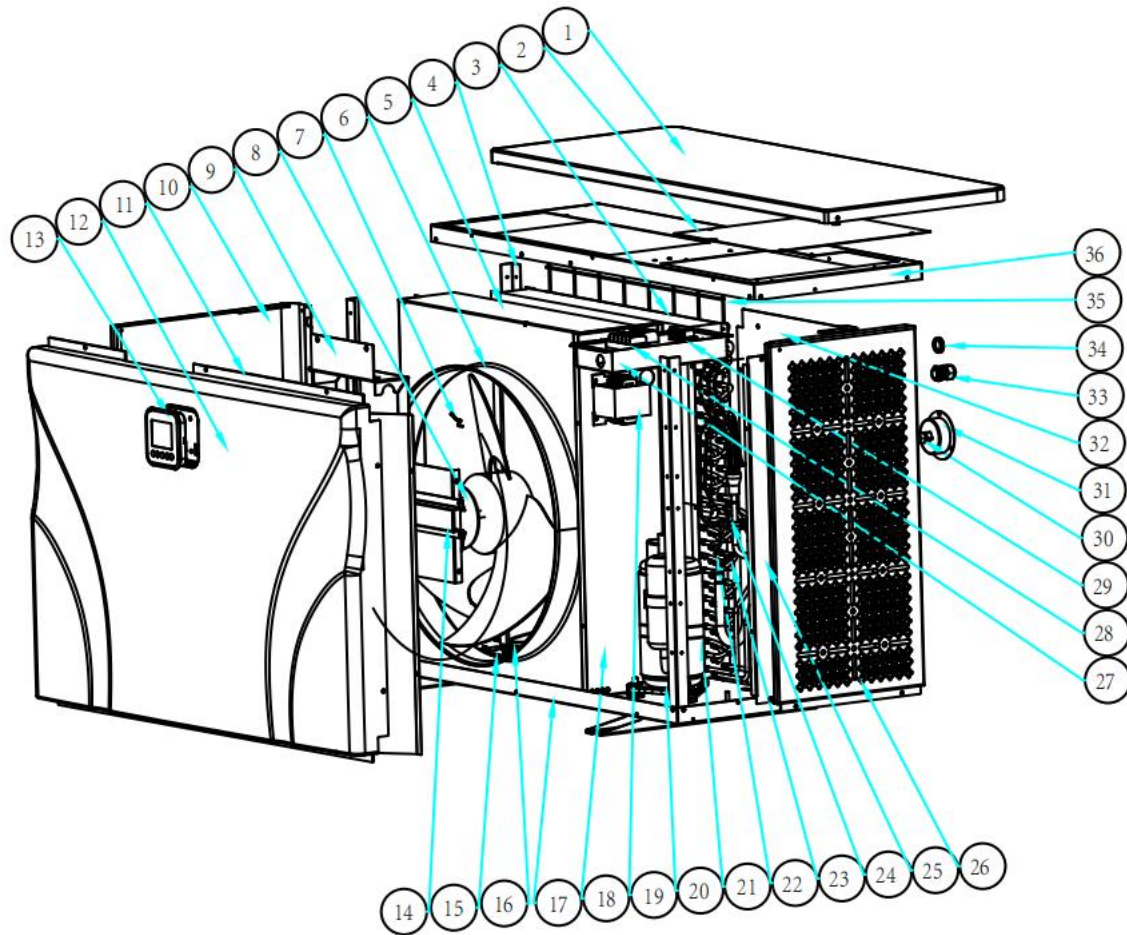

**UX11Csi32**

NO.	ERP	Part name	NO.	ERP	Part name
1	109060056	Coperchio superiore	34	136020119	Foro passacavi
2	109060053	Pannello di servizio	35	109060017	Griglia posteriore
3	103000335	Evaporatore	36	109060051	Telaio superiore
4	109060052	Colonna	37	119000058	EEV
5	109060023	Pannello ventola	38	121000037	Bobina della valvola a 4 vie
6	117110063	Sonda temp. ambiente	39	121000034	Valvola a 4 vie
7	132000015	Pala del ventilatore	40	117110050	Sonda evaporatore
8	112000031	Motoventilatore	41	113060188	Tube
9	109060027	Supporto motoventilatore	42	116000066	Mini-pessostato di altra pressione
10	109060058	Pannello sinistro	43	113020623	Tube
11	109060042	Pannello di servizio	44	113020579	Tube
12	133470001	Pannello frontale	45	/	Tube
13	117020293	Controller	46	116000071	Mini-pessostato di bassa pressione
14	109060054	Colonna	47	113080123	Tube
15	109060004	Supporto evaporatore	48	113030214	Tube
16	142000142	Resistenza riscaldamento evaporatore	49	113070067	Tube
17	109060050	Vaschetta base	50	108010025	Clip
18	109060059	Pannello isolante	51	117110057	Sonda temperatura acqua in uscita
19	117230003	Reattore	52	136010072	Anello di gomma sull'attacco dell'acqua
20	101000188	Compressore	53	116000103	Flussostato dell'acqua
21	142000072	Resistenza riscaldamento compressore	54	133020007	Copertura in PVC
22	113190007	Clip	55	133020012	Guarnizione di gomma rossa
23	113190001	Sede sonda	56	102050004	Set collegamento dell'acqua
24	117110061	Sonda di temperatura scarico	57	133020012	Guarnizione di gomma rossa
25	109060044	Pannello di servizio	58	102041113	Scambiatore di calore in titanio
26	109060057	Pannello destro	59	117110053	Sonda temperatura acqua entrata
27	108960058	Scatola di cablaggio	60	109060007	Coperchio scatola elettrica
28	115000004	Terminale di alimentazione	61	117100079	PCB
29	136010004	Clip	62	109060039	Scatola elettrica
30	124020011	Vite	63	117240002	Anello magnetico
31	106000012	Manometro	64	117240003	Anello magnetico
32	109060055	Pannello posteriore	65	117010122	Modulo Wi-Fi
33	110000039	Connettore del cavo			

**UX14Csi32**

NO.	ERP	Part name	NO.	ERP	Part name
1	109060056	Coperchio superiore	34	136020119	Foro passacavi
2	109060053	Pannello di servizio	35	109060017	Griglia posteriore
3	103000335	Evaporatore	36	109060051	Telaio superiore
4	109060052	Colonna	37	119000058	EEV
5	109060023	Pannello ventola	38	121000037	Bobina della valvola a 4 vie
6	117110063	Sonda temp. ambiente	39	121000034	Valvola a 4 vie
7	132000015	Pala del ventilatore	40	117110050	Sonda evaporatore
8	112000031	Motoventilatore	41	113060188	Tube
9	109060027	Supporto motoventilatore	42	116000066	Mini-pressostato di altra pressione
10	109060058	Pannello sinistro	43	113020623	Tube
11	109060042	Pannello di servizio	44	113020693	Tube
12	133470001	Pannello frontale	45	/	Tube
13	117020293	Controller	46	116000071	Mini-pressostato di bassa pressione
14	109060054	Colonna	47	113080123	Tube
15	109060004	Supporto evaporatore	48	113030214	Tube
16	142000142	Resistenza riscaldamento evaporatore	49	113070067	Tube
17	109060050	Vaschetta base	50	108010025	Clip
18	109060059	Pannello isolante	51	117110057	Sonda temperatura acqua in uscita
19	117230003	Reattore	52	136010072	Anello di gomma sull'attacco dell'acqua
20	101000188	Compressore	53	116000103	Flussostato dell'acqua
21	142000072	Resistenza riscaldamento compressore	54	133020007	Copertura in PVC
22	113190007	Clip	55	133020012	Guarnizione di gomma rossa
23	113190001	Sede sonda	56	102050004	Set collegamento dell'acqua
24	117110061	Sonda di temperatura scarico	57	133020012	Guarnizione di gomma rossa
25	109060044	Pannello di servizio	58	102041138	Scambiatore di calore in titanio
26	109060057	Pannello destro	59	117110053	Sonda temperatura acqua entrata
27	108960058	Scatola di cablaggio	60	109060007	Coperchio scatola elettrica
28	115000004	Terminale di alimentazione	61	117100076	PCB
29	136010004	Clip	62	109060039	Scatola elettrica
30	124020011	Vite	63	117240002	Anello magnetico
31	106000012	Manometro	64	117240003	Anello magnetico
32	109060055	Pannello posteriore	65	117010122	Modulo Wi-Fi
33	110000039	Connettore del cavo			

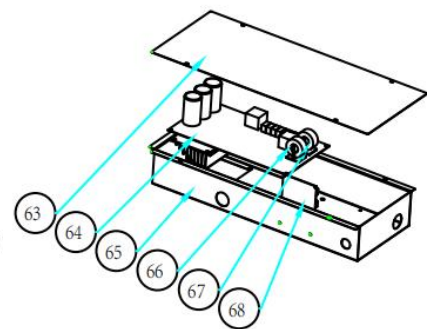
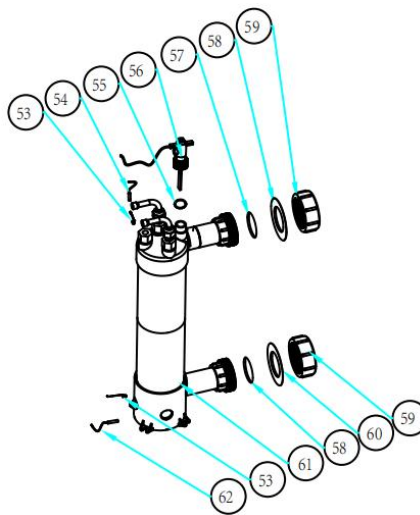
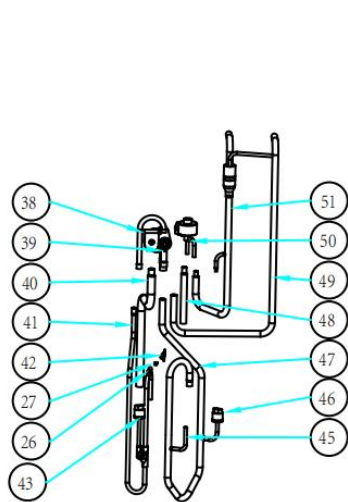
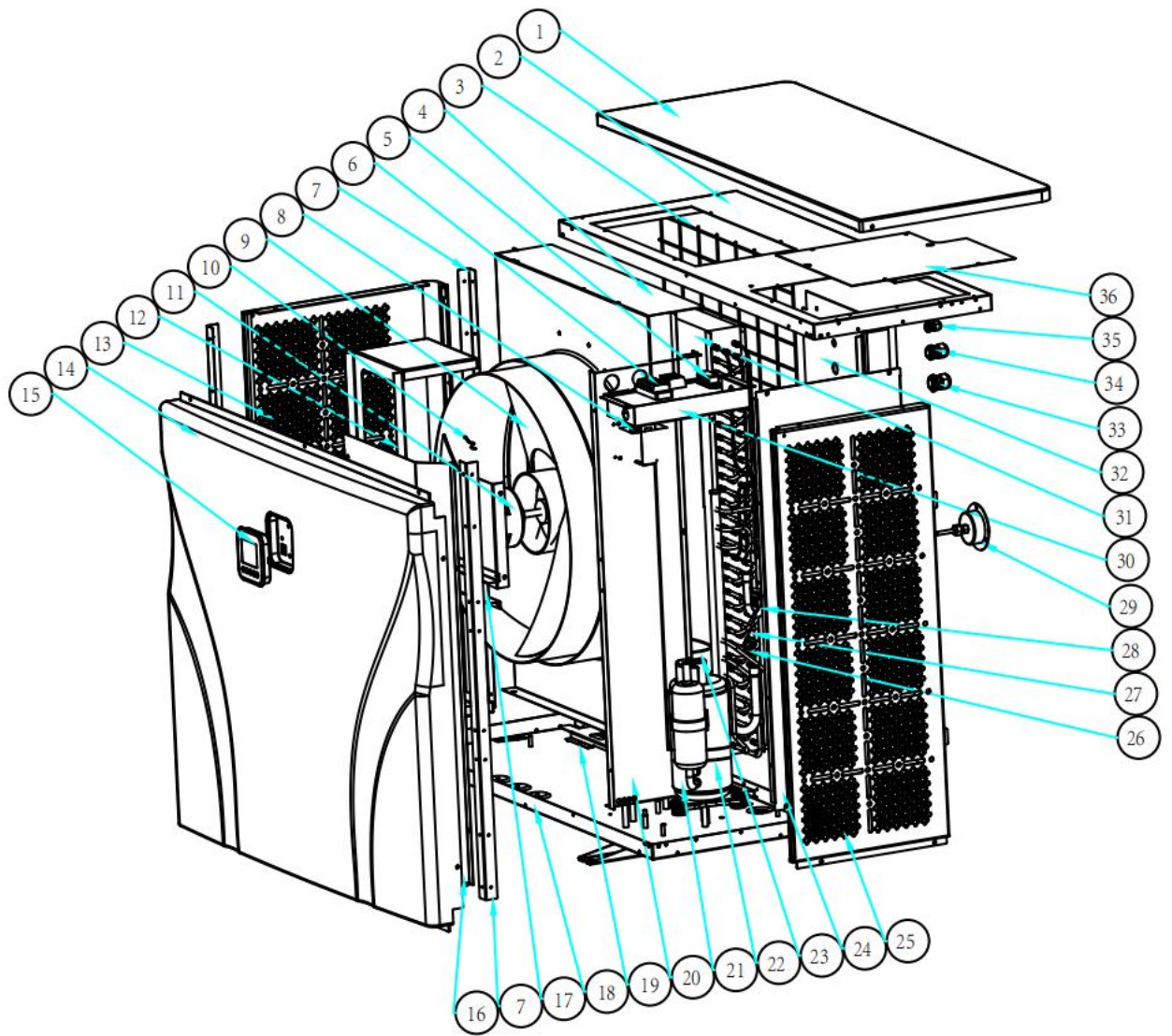

**UX17Csi32**

NO.	ERP	Part name	NO.	ERP	Part name
1	108960050	Coperchio superiore	35	110000036	Connettore del cavo
2	108960057	Telaio superiore	36	108960053	Pannello di servizio
3	108840091	Griglia posteriore	37	/	/
4	108960061	Pannello ventola	38	121000037	Bobina della valvola a 4 vie
5	136010004	Clip	39	121000034	Valvola a 4 vie
6	115000004	Terminale di alimentazione	40	113060208	Tube
7	108960037	Colonna	41	113010440	Tube
8	117230003	Reattore	42	117110050	Sonda evaporatore
9	132000023	Pala del ventilatore	43	116000067	Mini-pressostato di altra pressione
10	112000031	Motoventilatore	44	/	/
11	117110063	Sonda temp. ambiente	45	/	Tube
12	108960060	Supporto motoventilatore	46	116000073	Mini-pressostato di bassa pressione
13	108960073	Pannello sinistro	47	113020673	Tube
14	133450001	Pannello frontale	48	113080128	Tube
15	117020293	Controller	49	113030212	Tube
16	108960062	Pannello di servizio	50	119000058	EEV
17	108960052	Colonna	51	113070065	Tube
18	108960074	Vaschetta base	52	/	/
19	108960002	Supporto evaporatore	53	108010025	Clip
20	108960063	Pannello isolante	54	117110057	Sonda temperatura acqua in uscita
21	101000181	Compressore	55	136010072	Anello di gomma sull'attacco dell'acqua
22	142000074	Resistenza riscaldamento compressore	56	116000065	Flussostato dell'acqua
23	142000142	Resistenza riscaldamento evaporatore	57	133020007	Copertura in PVC
24	108960065	Pannello di servizio	58	133020012	Guarnizione di gomma rossa
25	108960072	Pannello destro	59	102050004	Set collegamento dell'acqua
26	113190001	Sede sonda	60	133020011	Anello gomma blu
27	113190007	Clip	61	102041110	Scambiatore di calore in titanio
28	117110061	Sonda di temperatura scarico	62	117110053	Sonda temperatura acqua entrata
29	106000012	Manometro	63	108960007	Coperchio scatola elettrica
30	108960058	Scatola di cablaggio	64	117100076	PCB
31	103000360	Evaporatore	65	108960054	Scatola elettrica
32	108960075	Pannello posteriore	66	117240002	Anello magnetico
33	110000048	Connettore del cavo	67	117240003	Anello magnetico
34	110000039	Connettore del cavo	68	117010122	Modulo Wi-Fi

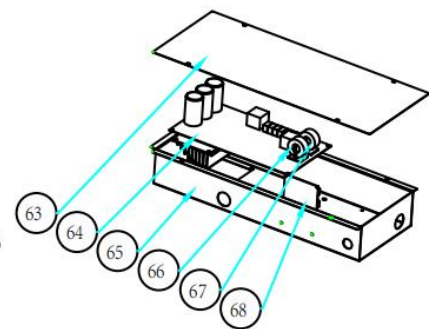
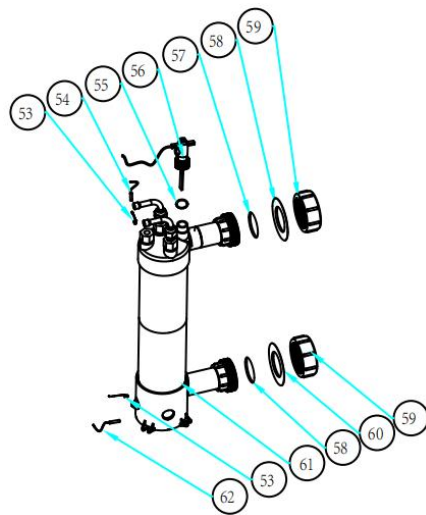
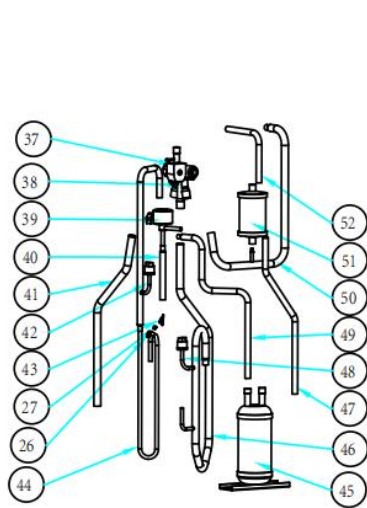
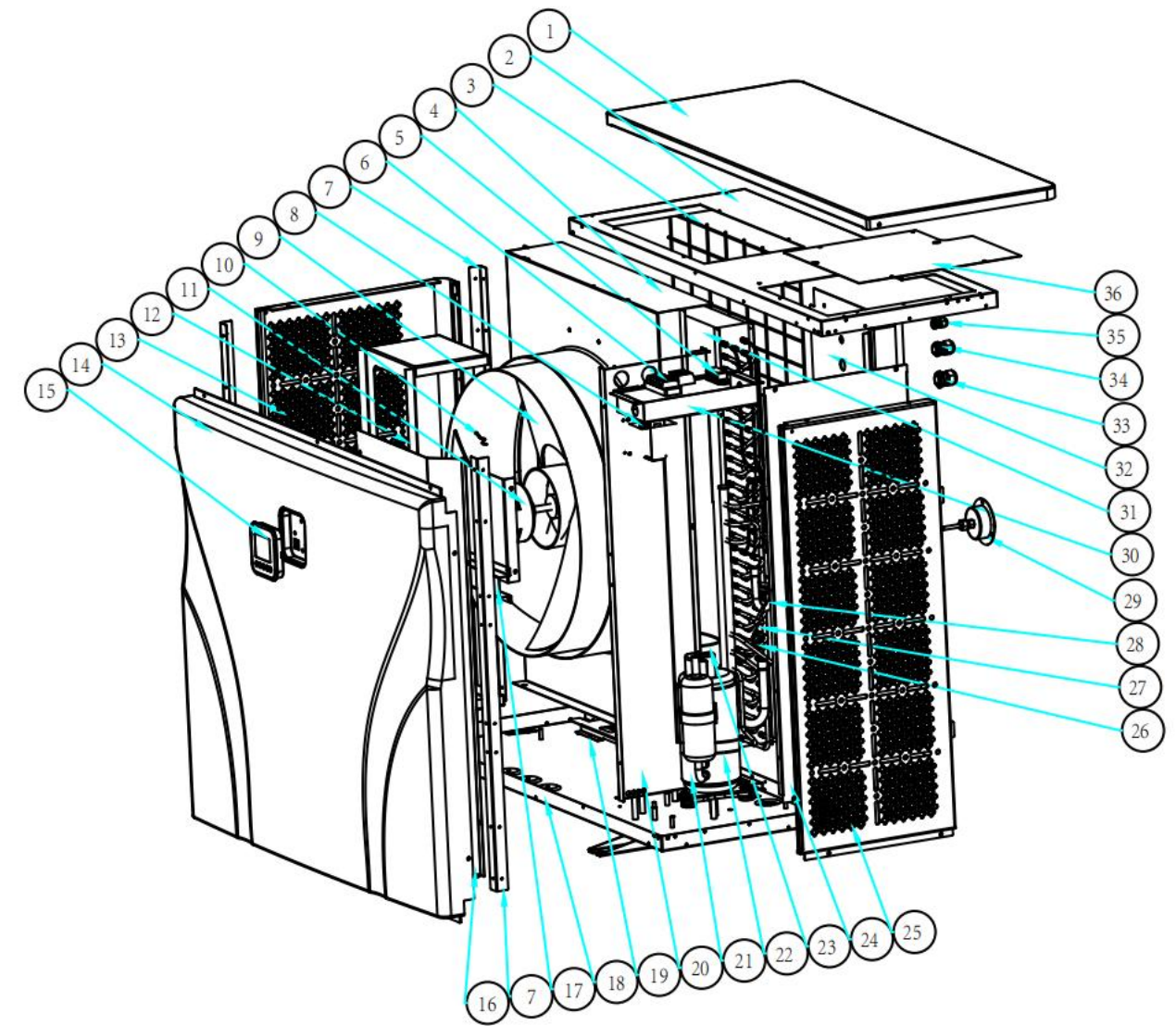

**UX21Csi32**

NO.	ERP	Part name	NO.	ERP	Part name
1	108960050	Coperchio superiore	35	110000036	Connettore del cavo
2	108960057	Telaio superiore	36	108960053	Pannello di servizio
3	108840091	Griglia posteriore	37	121000028	Valvola a 4 vie
4	108960061	Pannello ventola	38	121000037	Bobina della valvola a 4 vie
5	136010004	Clip	39	119000066	EEV
6	115000004	Terminale di alimentazione	40	113080128	Tube
7	108960037	Colonna	41	113060193	Tube
8	117230003	Reattore	42	116000068	Mini-pressostato di alta pressione
9	132000023	Pala del ventilatore	43	117110050	Sonda evaporatore
10	112000031	Motoventilatore	44	113010434	Tube
11	117110063	Sonda temp. ambiente	45	105000004	Serbatoio di stoccaggio liquidi
12	108960060	Supporto motoventilatore	46	113020683	Tube
13	108960073	Pannello sinistro	47	113130041	Tube
14	133450001	Pannello frontale	48	116000073	Mini-pressostato di bassa pressione
15	117020293	Controller	49	113120065	Tube
16	108960062	Pannello di servizio	50	113030216	Tube
17	108960052	Colonna	51	120000066	Filtro disidratatore
18	108960079	Vaschetta base	52	113170079	Tube
19	108960002	Supporto evaporatore	53	108010025	Clip
20	108960063	Pannello isolante	54	117110057	Sonda temperatura acqua in uscita
21	101000252	Compressore	55	136010072	Anello di gomma sull'attacco dell'acqua
22	142000072	Resistenza riscaldamento compressore	56	116000065	Flussostato dell'acqua
23	142000142	Resistenza riscaldamento evaporatore	57	133020007	Copertura in PVC
24	108960065	Pannello di servizio	58	133020012	Guarnizione di gomma rossa
25	108960072	Pannello destro	59	102050004	Set collegamento dell'acqua
26	113190001	Sede sonda	60	133020011	Anello gomma blu
27	113190007	Clip	61	102041110	Scambiatore di calore in titanio
28	117110061	Sonda di temperatura scarico	62	117110053	Sonda temperatura acqua entrata
29	106000012	Manometro	63	108960007	Coperchio scatola elettrica
30	108960058	Scatola di cablaggio	64	117100076	PCB
31	103000337	Evaporatore	65	108960054	Scatola elettrica
32	108960075	Pannello posteriore	66	117240002	Anello magnetico
33	110000048	Connettore del cavo	67	117240003	Anello magnetico
34	110000039	Connettore del cavo	68	117010122	Modulo Wi-Fi

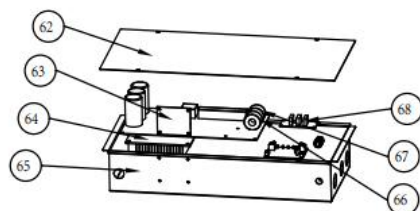
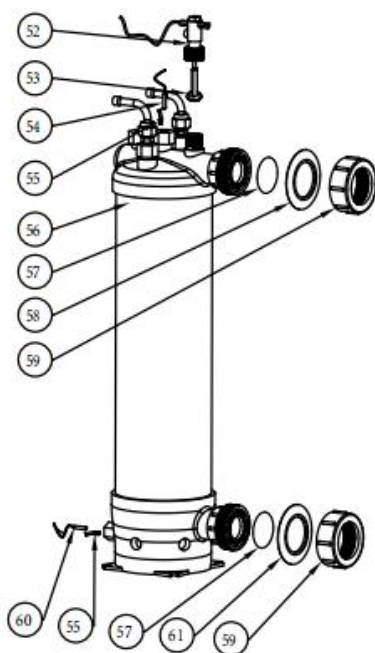
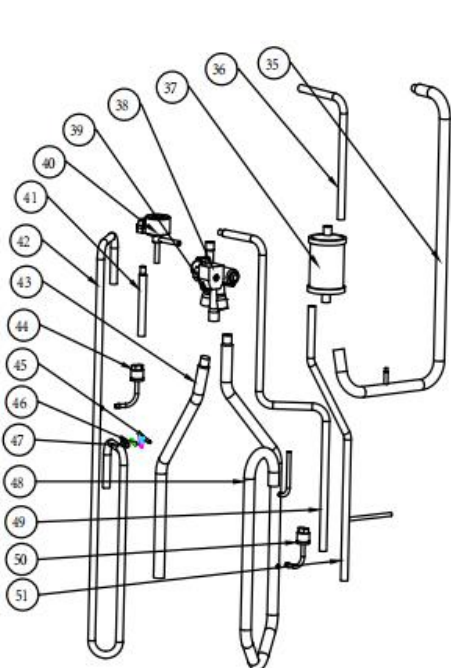
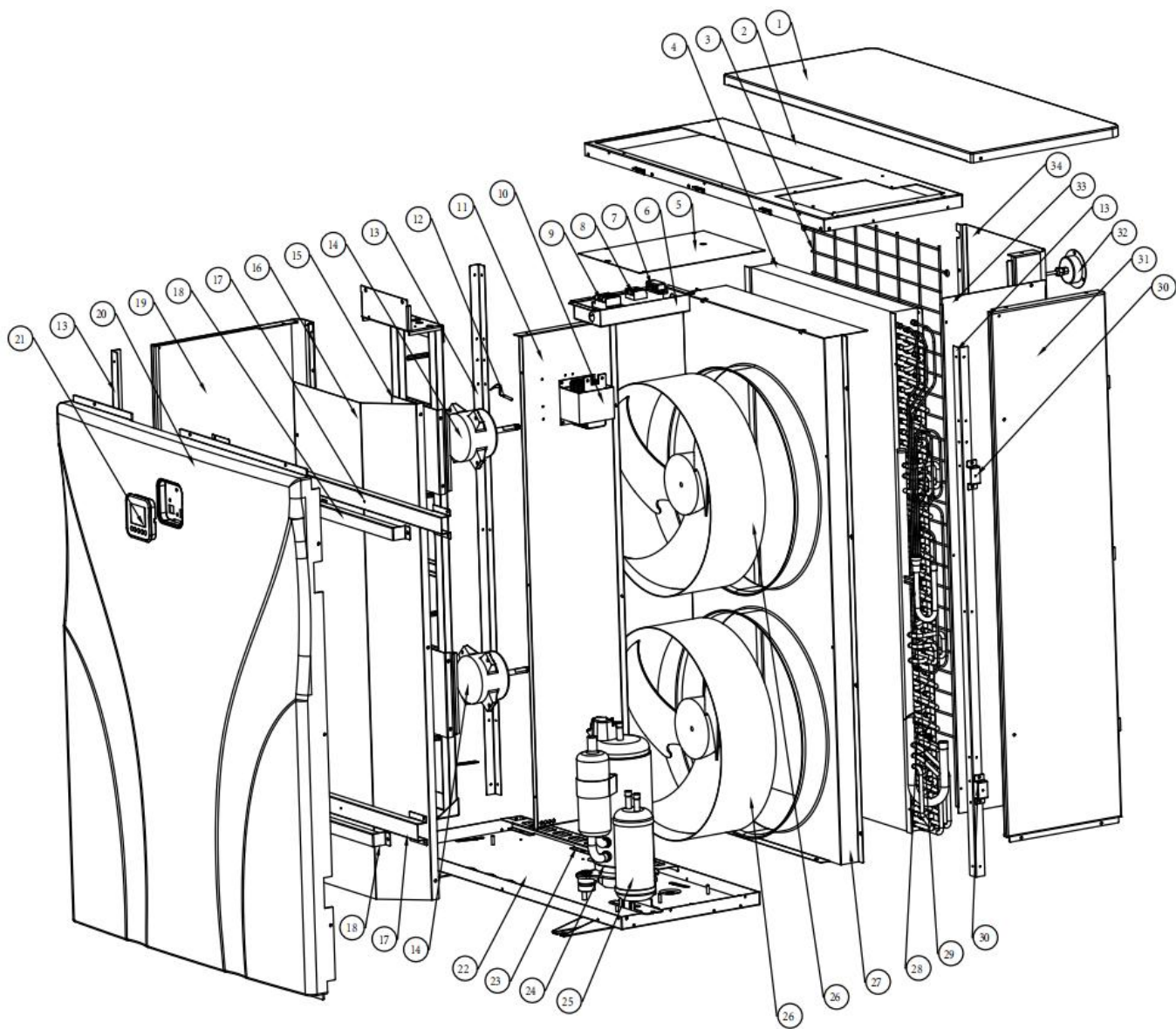



**UX26Csi32**

NO.	ERP	Part name	NO.	ERP	Part name
1	108940051	Coperchio superiore	35	113030215	Tube
2	108940059	Telaio superiore	36	113170078	Tube
3	108940012	Griglia posteriore	37	120000066	Filtro disidratatore
4	103000354	Evaporatore	38	121000037	Bobina della valvola a 4 vie
5	108940034	Pannello di servizio	39	121000028	Valvola a 4 vie
6	108960058	Scatola di cablaggio	40	119000059	EEV
7	136010004	Clip	41	113080116	Tube
8	115000012	Terminale di alimentazione	42	113020621	Tube
9	115000025	Terminale di alimentazione	43	113060211	Tube
10	117230002	Reattore	44	116000068	Mini-pressostato di altra pressione
11	108940060	Pannello isolante	45	117110051	Sonda di temperatura scarico
12	117110063	Sonda temp. ambiente	46	113190007	Clip
13	108940047	Colonna	47	113190001	Sede sonda
14	112000031	Motoventilatore	48	113020703	Tube
15	108940016	Supporto motoventilatore	49	113130040	Tube
16	108940035	Pannello di servizio	50	116000073	Mini-pressostato di bassa pressione
17	108940048	Colonna	51	113120063	Tube
18	108960081	Colonna	52	116000065	Flussostato dell'acqua
19	108940057	Pannello sinistro	53	136010089	Anello di gomma sull'attacco dell'acqua
20	133480002	Pannello frontale	54	117110057	Sonda temperatura acqua in uscita
21	117020293	Controller	55	108010025	Clip
22	108940043	Vaschetta base	56	102041127	Scambiatore di calore in titanio
23	108940004	Supporto evaporatore	57	133020007	Copertura in PVC
24	101000185	Compressore	58	133020012	Guarnizione di gomma rossa
25	105000015	Serbatoio di stoccaggio liquidi	59	102050004	Set collegamento dell'acqua
26	132000015	Pala del ventilatore	60	117110053	Sonda temperatura acqua entrata
27	108940056	Pannello ventola	61	133020011	Anello gomma blu
28	117110050	Sonda evaporatore	62	108940062	Coperchio scatola elettrica
29	136020005	Blocco di gomma	63	117010122	Modulo Wi-Fi
30	109070064	Colonna	64	117100077	PCB
31	108940058	Pannello destro	65	108940061	Scatola elettrica
32	106000012	Manometro	66	117240002	Anello magnetico
33	108940036	Pannello di servizio	67	117240003	Anello magnetico
34	108940053	Pannello posteriore	68	117010081	Clip

UX30Csi32/UX30Csi32T/UX35Csi32T

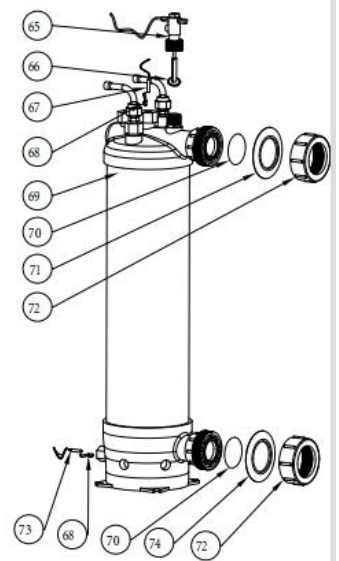
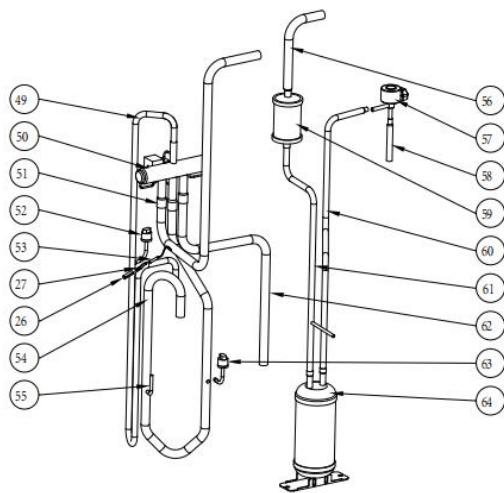
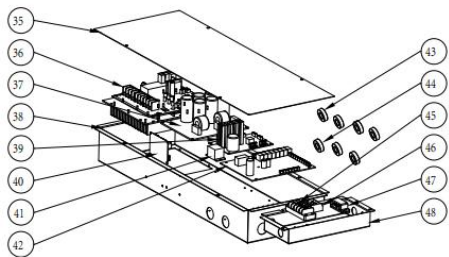
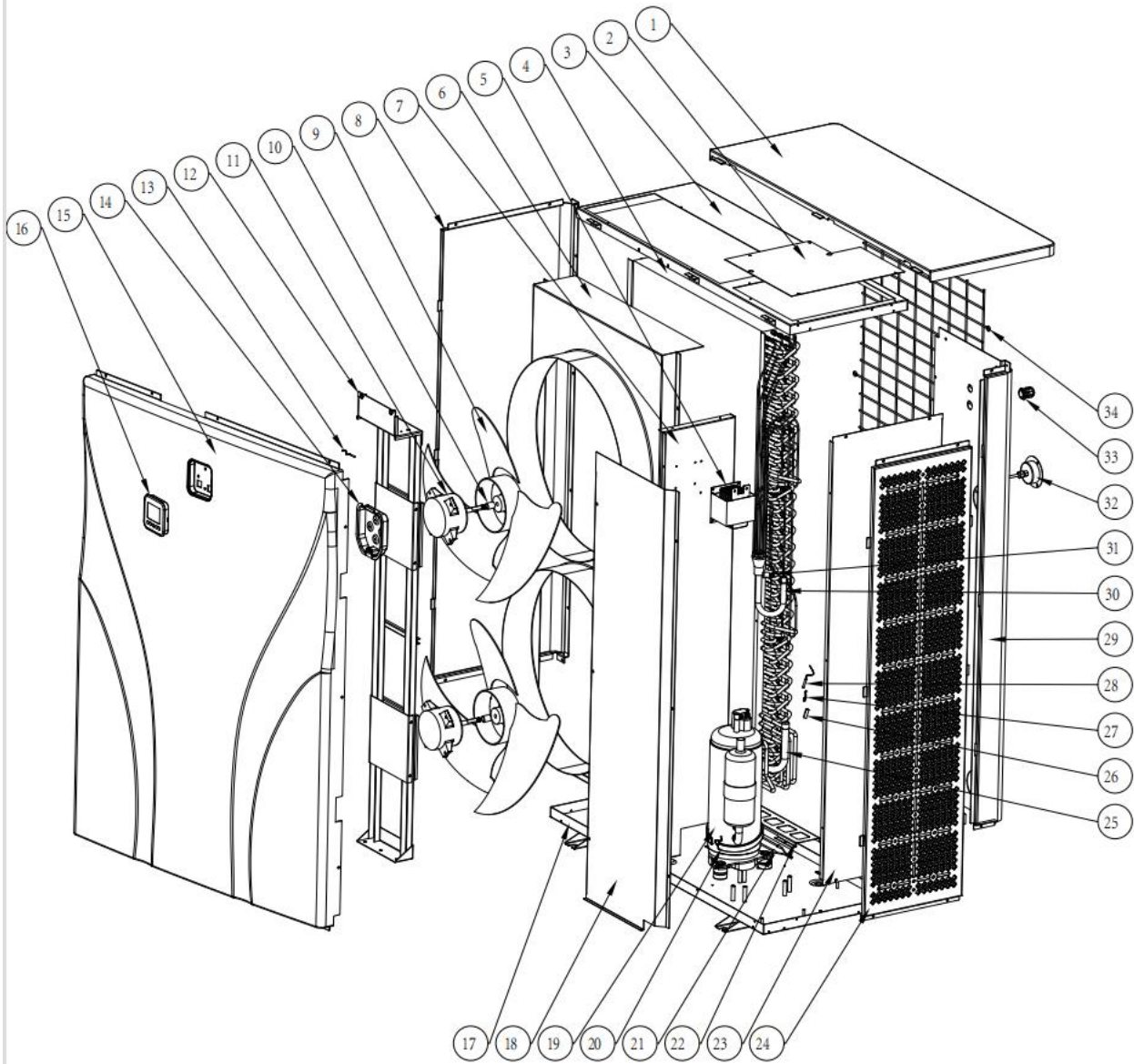

**UX30Csi32**

NO.	ERP	Part name	NO.	ERP	Part name
1	109070060	Coperchio superiore	38	109070006	Scatola elettrica
2	109070052	Pannello di servizio	39	/	/
3	109070051	Telaio superiore	40	117010122	Modulo Wi-Fi
4	103000331	Evaporatore	41	142000038	Relè
5	117230002	Reattore	42	117250021	PCB
6	109070019	Pannello ventola	43	117240002	Anello magnetico
7	109070026	Pannello isolante	44	117240003	Anello magnetico
8	109070057	Pannello sinistro	45	115000025	Terminale di alimentazione
9	132000023	Pala del ventilatore	46	115000023	Terminale di alimentazione
10	108010024	Gruppo motore del ventilatore	47	136010004	Clip
11	112000031	Motoventilatore	48	108960058	Scatola di cablaggio
12	109070021	Supporto motoventilatore	49	113010444	Tubo
13	117110063	Sonda temp. ambiente	50	121000028	Valvola a 4 vie
14	133030020	Scatola del controller	51	113030183	Tubo
15	133460001	Pannello frontale	52	116000068	Mini-pressostato di altra pressione
16	117020293	Controller	53	117110051	Sonda di temperatura scarico
17	109070065	Vaschetta base	54	113020684	Tubo
18	109070053	Pannello di servizio	55	113020685	Tubo
19	101000185	Compressore	56	113070061	Tube
20	142000077	Resistenza riscaldamento compressore	57	119000061	EEV
21	142000079	Resistenza riscaldamento evaporatore	58	113080116	Tubo
22	109070004	Supporto evaporatore	59	120000066	Filtro disidratatore
23	109070054	Pannello di servizio	60	113120053	Tube
24	109070058	Pannello destro	61	113130039	Tube
25	103000331	Tubo	62	113060214	Tubo
26	113190001	Sede sonda	63	116000073	Mini-pressostato di bassa pressione
27	113190007	Clip	64	105000015	Serbatoio di stoccaggio liquidi
28	117110050	Sonda evaporatore	65	116000065	Flussostato dell'acqua
29	109070062	Pannello posteriore	66	136020083	Anello di gomma sull'attacco dell'acqua
30	103000331	Tubo	67	117110057	Sonda temperatura acqua in uscita
31	136020005	Blocco di gomma	68	108010025	Clip
32	106000012	Manometro	69	102041106	Scambiatore di calore in titanio
33	110000038	Connettore del cavo	70	133020006	Anello di gomma sul collegamento dell'acqua
34	109070022	Griglia posteriore	71	133020012	Guarnizione di gomma rossa
35	109070007	Coperchio scatola elettrica	72	102050004	Set collegamento dell'acqua
36	117140016	Scheda driver 3 fasi	73	117110053	Sonda temperatura acqua entrata
37	117260001	Scheda filtro	74	133020011	Anello gomma blu

**UX30Csi32T**

NO.	ERP	Part name	NO.	ERP	Part name
1	109070060	Coperchio superiore	38	109070006	Scatola elettrica
2	109070052	Pannello di servizio	39	/	/
3	109070051	Telaio superiore	40	117010122	Modulo Wi-Fi
4	103000331	Evaporatore	41	142000038	Relè
5	117230002	Reattore	42	117250022	PCB
6	109070019	Pannello ventola	43	117240002	Anello magnetico
7	109070068	Pannello isolante	44	117240003	Anello magnetico
8	109070070	Pannello sinistro	45	115000006	Terminale di alimentazione
9	132000023	Pala del ventilatore	46	115000023	Terminale di alimentazione
10	108010024	Gruppo motore del ventilatore	47	136010004	Clip
11	112000031	Motoventilatore	48	108960058	Scatola di cablaggio
12	109070021	Supporto motoventilatore	49	113020636	Tubo
13	117110063	Sonda temp. ambiente	50	121000028	Valvola a 4 vie
14	133030020	Scatola del controller	51	113030183	Tubo
15	133460001	Pannello frontale	52	116000068	Mini-pressostato di altra pressione
16	117020293	Controller	53	117110051	Sonda di temperatura scarico
17	180060001	Vaschetta base	54	113020697	Tubo
18	109070069	Pannello di servizio	55	/	Tubo
19	101000239	Compressore	56	113070061	Tube
20	142000077	Resistenza riscaldamento compressore	57	119000061	EEV
21	142000079	Resistenza riscaldamento evaporatore	58	113080116	Tubo
22	109070004	Supporto evaporatore	59	120000066	Filtro disidratatore
23	109070066	Pannello di servizio	60	113120053	Tube
24	109070058	Pannello destro	61	113130039	Tube
25	103000331	Tubo	62	113060214	Tubo
26	113190001	Sede sonda	63	116000073	Mini-pressostato di bassa pressione
27	113190007	Clip	64	105000015	Serbatoio di stoccaggio liquidi
28	117110050	Sonda evaporatore	65	116000065	Flussostato dell'acqua
29	109070062	Pannello posteriore	66	136020083	Anello di gomma sull'attacco dell'acqua
30	103000331	Tubo	67	117110057	Sonda temperatura acqua in uscita
31	136020005	Blocco di gomma	68	108010025	Clip
32	106000012	Manometro	69	102041106	Scambiatore di calore in titanio
33	110000038	Connettore del cavo	70	133020006	Anello di gomma sul collegamento dell'acqua
34	109070022	Griglia posteriore	71	133020012	Guarnizione di gomma rossa
35	109070007	Coperchio scatola elettrica	72	102050004	Set collegamento dell'acqua
36	117140019	Scheda driver 3 fasi	73	117110053	Sonda temperatura acqua entrata
37	117260002	Scheda filtro	74	133020011	Anello gomma blu

**UX35Csi32T**

NO.	ERP	Part name	NO.	ERP	Part name
1	109070060	Coperchio superiore	38	109070006	Scatola elettrica
2	109070052	Pannello di servizio	39	/	/
3	109070051	Telaio superiore	40	117010122	Modulo Wi-Fi
4	103000356	Evaporatore	41	142000038	Relè
5	117230002	Reattore	42	117250022	PCB
6	109070019	Pannello ventola	43	117240002	Anello magnetico
7	109070068	Pannello isolante	44	117240003	Anello magnetico
8	109070070	Pannello sinistro	45	115000006	Terminale di alimentazione
9	132000023	Pala del ventilatore	46	115000023	Terminale di alimentazione
10	108010024	Gruppo motore del ventilatore	47	136010004	Clip
11	112000031	Motoventilatore	48	108960058	Scatola di cablaggio
12	109070021	Supporto motoventilatore	49	113020636	Tubo
13	117110063	Sonda temp. ambiente	50	121000028	Valvola a 4 vie
14	133030020	Scatola del controller	51	113030183	Tubo
15	133460001	Pannello frontale	52	116000068	Mini-pressostato di altra pressione
16	117020293	Controller	53	117110051	Sonda di temperatura scarico
17	180060001	Vaschetta base	54	113020697	Tubo
18	109070069	Pannello di servizio	55	/	Tubo
19	101000239	Compressore	56	113070061	Tube
20	142000077	Resistenza riscaldamento compressore	57	119000061	EEV
21	142000079	Resistenza riscaldamento evaporatore	58	113080116	Tubo
22	109070004	Supporto evaporatore	59	120000066	Filtro disidratatore
23	109070066	Pannello di servizio	60	113120053	Tube
24	109070058	Pannello destro	61	113130039	Tube
25	103000356	Tubo	62	113060214	Tubo
26	113190001	Sede sonda	63	116000073	Mini-pressostato di bassa pressione
27	113190007	Clip	64	105000015	Serbatoio di stoccaggio liquidi
28	117110050	Sonda evaporatore	65	116000065	Flussostato dell'acqua
29	109070062	Pannello posteriore	66	136020083	Anello di gomma sull'attacco dell'acqua
30	103000356	Tubo	67	117110057	Sonda temperatura acqua in uscita
31	136020005	Blocco di gomma	68	108010025	Clip
32	106000012	Manometro	69	102041106	Scambiatore di calore in titanio
33	110000038	Connettore del cavo	70	133020006	Anello di gomma sul collegamento dell'acqua
34	109070022	Griglia posteriore	71	133020012	Guarnizione di gomma rossa
35	109070007	Coperchio scatola elettrica	72	102050004	Set collegamento dell'acqua
36	117140019	Scheda driver 3 fasi	73	117110053	Sonda temperatura acqua entrata
37	117260002	Scheda filtro	74	133020011	Anello gomma blu

# **Manual del usuario y de servicio**

## **INVERBOOST INVERTER**

**Reglamento (EU) n ° 517/2014 del 16/04/14 sobre gases fluorados de efecto invernadero y anulación del Reglamento (CE) n ° 842/2006**

**Inspección de fugas**

1. Los propietarios o mantenedores de equipos que contengan gases invernaderos fluorados en cantidades de 5 toneladas de CO<sub>2</sub>, equivalentes o más y no contenidas en espumas deberán asegurarse de que el equipo se ha comprobado si tiene fugas.

2. Para equipos que contengan gases fluorados de efecto invernadero en cantidades de 5 toneladas de CO<sub>2</sub> equivalente o más, pero de menos de 50 toneladas de CO<sub>2</sub> equivalente: Revisar al menos cada 12 meses.

**Equivalencia de CO<sub>2</sub>**

1. Carga en kg y toneladas de CO<sub>2</sub>.

Carga y toneladas de CO <sub>2</sub>	Frecuencia de la prueba
De 7 a 75 kg carga = de 5 a 50 Toneladas	Cada año

**No expulsar R32 a la atmósfera. Este líquido es un gas fluorado de efecto invernadero cubierto por el protocolo de Kyoto, con un potencial de calentamiento global (GWP) = 675 - (consulte la normativa de la Comunidad Europea sobre el Reglamento de gases fluorados de efecto invernadero, (UE - 517/2014).**

**En cuanto al Gas R32, 7.40kg con un valor de 5 toneladas de CO<sub>2</sub>, se compromete a revisarlo cada año.**

**Mantenedor Certificado**

1. El propietario o mantenedor debe garantizar que el personal pertinente haya obtenido la certificación necesaria, lo que implica un conocimiento adecuado de las normas y reglamentaciones aplicables, así como la competencia necesaria en materia de prevención de emisiones y recuperación de gases fluorados tipo y tamaño del equipo.

**Mantenimiento de registros**

1. El personal de mantenimiento que requiera verificar fugas deberán establecer y mantener registros para cada pieza de dicho equipo, especificando la siguiente información:

A) La cantidad y el tipo de gases fluorados de efecto invernadero instalados;

B) La cantidad de gases fluorados de efecto invernadero añadidas durante la instalación, el mantenimiento o el servicio o debido a fugas;

C) si se han reciclado o recuperado la cantidad de gases fluorados de efecto invernadero instalados, incluido el nombre y la dirección de la instalación de reciclado o de regeneración y, en su caso, el número del certificado;

D) La cantidad de gases fluorados de efecto invernadero recuperados

E) La identidad de la empresa instaladora, reparadora, mantenedora y, en su caso, la empresa desmanteladora del equipo, incluido, en su caso, el número de su certificado;

F) Las fechas y resultados de los controles efectuados;

G) Si el equipo fuera desmantelado, las medidas adoptadas para recuperar y tratar de los gases fluorados de efecto invernadero

2. El operador debe conservar los registros durante al menos cinco años, las empresas que realicen las actividades de los operadores deben conservar las copias de los registros durante al menos cinco años.

## INDEX

1. Ficha Técnica
2. Ficha Técnica
3. Kit de Instalación
4. Ajuste del kit de derivación
5. Funcionamiento del controlador
6. Solución de Problemas
7. Cableado Eléctrico
8. Mantenimiento
9. Diagrama de despiece

Gracias por usar la bomba de calor de piscina INVERBOOST INVERTER para calentar su piscina, calentará el agua de su piscina y mantendrá la temperatura constante cuando la temperatura ambiente del aire sea de -20 a 43 °C.



**ATENCIÓN:** Este manual incluye toda la información necesaria para el uso e instalación de su bomba de calor.

El instalador debe leer el manual y seguir atentamente las instrucciones de implementación y mantenimiento.

El instalador es responsable de la instalación del producto y debe seguir todas las instrucciones del fabricante y las regulaciones en aplicación. La instalación incorrecta contra el manual implica la exclusión de toda la garantía.

El fabricante declina cualquier responsabilidad por los daños causados a las personas, objetos y de los errores debidos a la instalación que desobedezcan las pautas del manual. Cualquier uso que no sea conforme al origen de su fabricación será considerado peligroso.

**ADVERTENCIA:** Vacíe siempre el agua de la bomba de calor durante el invierno o cuando la temperatura ambiente descienda por debajo de 0 °C, de lo contrario, el intercambiador de titanio se dañará por congelación, en tal caso, perderá la garantía.

**ADVERTENCIA:** Siempre corte la fuente de alimentación si desea abrir el gabinete para acceder al interior de la bomba de calor, porque hay electricidad de alto voltaje en el interior.

**ADVERTENCIA:** Guarde bien el controlador de pantalla en un lugar seco o cierre bien la cubierta de aislamiento para proteger el controlador de pantalla de los daños causados por la humedad.



# 1. Ficha Técnica

Modello		UX11Csi32	UX14Csi32	UX17Csi32
<b>* Performance at Air 28°C, Water 28°C, Humidity 80%</b>				
Capacidad de calentamiento Turbo	kW	11.0	14.0	17.0
Capacidad de calentamiento Smart	kW	10.0	11.0	14.0
El consumo de energía	kW	1.55-0.17	1.97-0.22	2.39-0.27
C.O.P.		16-7.4	16-7.1	16-7.2
C.O.P. in Turbo Mode		7.4	7.1	7.2
C.O.P. at 50% capacity		11.8	11.0	11.8
<b>* Performance at Air 15°C, Water 26°C, Humidity 70%</b>				
Capacidad de calentamiento Turbo	kW	8.5	9.5	12.0
Capacidad de calentamiento Smart	kW	7.0	8.0	10.5
El consumo de energía	kW	1.67-0.26	1.90-0.29	2.31-0.37
C.O.P.		8.2-5.1	8.21-5	8.5-5.2
C.O.P. in Turbo Mode		5.1	5.0	5.2
C.O.P. at 50% capacity		7.1	7.0	7.8
<b>* Informacion General</b>				
Tipo de compresor		Inverter compressor		
Voltaje		220-240V/50Hz/1PH		
Corriente nominal	A	6.9	8.7	10.6
Corriente maxima	A	10.5	13.5	15.5
Fusible mínimo	A	12.0	15.0	16.0
Flujo de agua aconsejado	m³/h	3.7	4.0	5.0
Caída de presión de agua	Kpa	12.0	14.0	15.0
Intercambiador de calor		Twist-titanium tube in PVC		
Conexión de agua	mm	50		
Cantidad de ventiladores		1		
Tipo de ventilacion		Horizontal		
Nivel sonoro a 10m	dB(A)	17.8-26.2	21.7-26.7	22.6-28.1
Nivel sonoro a 1m	dB(A)	36-46.2	38-47.6	39.5-49.8
<b>* Dimensión / Peso</b>				
Peso neto	kg	73	78	98
Peso bruto	kg	78	83	113
Dimensión neta	mm	1028*441*685	1028*441*685	1073*492*886
Dimensión de embalaje	mm	1095*525*830	1095*525*830	1140*555*1030

Modello		UX21Csi32	UX26Csi32	UX30Csi32
<b>* Performance at Air 28°C, Water 28°C, Humidity 80%</b>				
Capacidad de calentamiento Turbo	kW	21.0	26.0	30.0
Capacidad de calentamiento Smart	kW	18.0	21.0	25.0
El consumo de energía	kW	2.96-0.33	3.66-0.29	4.17-0.47
C.O.P.		16-7.1	16-7.1	16-7.1
C.O.P. in Turbo Mode		7.1	7.1	7.1
C.O.P. at 50% capacity		11.2	11.2	11.2
<b>* Performance at Air 15°C, Water 26°C, Humidity 70%</b>				
Capacidad de calentamiento Turbo	kW	15.5	18.0	20.0
Capacidad de calentamiento Smart	kW	13.5	16.0	18.0
El consumo de energía	kW	3.04-0.47	3.53-0.55	3.92-0.61
C.O.P.		8.3-5.1	8.2-5.1	8.2-5.1
C.O.P. in Turbo Mode		5.1	5.1	5.1
C.O.P. at 50% capacity		7.4	7.2	7.2
<b>* Informacion General</b>				
Tipo de compresor		Inverter compressor		
Voltaje		220-240V/50Hz/1PH		
Corriente nominal	A	13.1	16.3	18.5
Corriente maxima	A	19.5	24.0	28.0
Fusible mínimo	A	22	28	32
Flujo de agua aconsejado	m <sup>3</sup> /h	6.0	8.0	10.0
Caída de presión de agua	Kpa	15	18	20
Intercambiador de calor		Twist-titanium tube in PVC		
Conexión de agua	mm	50		
Cantidad de ventiladores		1	2	2
Tipo de ventilacion		Horizontal		
Nivel sonoro a 10m	dB(A)	22.9-30.6	23.1-31.8	23.2-32.4
Nivel sonoro a 1m	dB(A)	40-51	41-51.6	42-51.8
<b>* Dimensión / Peso</b>				
Peso neto	kg	117	125	130
Peso bruto	kg	135	145	148
Dimensión neta	mm	1073*492*886	1039*509*1289	1113*519*1410
Dimensión de embalaje	mm	1185*530*1030	1185*565*1435	1225*540*1555

Modello		UX30Csi32T	UX35Csi32T
<b>* Performance at Air 28°C, Water 28°C, Humidity 80%</b>			
Capacidad de calentamiento Turbo	kW	30.0	35.0
Capacidad de calentamiento Smart	kW	25.0	30.0
El consumo de energía	kW	4.17-0.47	4.93-0.55
C.O.P.		16-7.1	16-7.1
C.O.P. in Turbo Mode		7.1	7.1
C.O.P. at 50% capacity		11.2	11.2
<b>* Performance at Air 15°C, Water 26°C, Humidity 70%</b>			
Capacidad de calentamiento Turbo	kW	20.0	24.0
Capacidad de calentamiento Smart	kW	18.0	22.0
El consumo de energía	kW	3.85-0.61	4.62-0.73
C.O.P.		8.2-5.2	8.2-5.2
C.O.P. in Turbo Mode		5.2	5.2
C.O.P. at 50% capacity		7.2	7.2
<b>* Informacion General</b>			
Tipo de compresor		Inverter compressor	
Voltaje		380V/50Hz/3PH	
Corriente nominal	A	7.5	8.8
Corriente maxima	A	12.0	14.0
Fusible mínimo	A	15	17
Flujo de agua aconsejado	m³/h	10.0	15.0
Caída de presión de agua	Kpa	20	25
Intercambiador de calor		Twist-titanium tube in PVC	
Conexión de agua	mm	50	
Cantidad de ventiladores		2	2
Tipo de ventilacion		Horizontal	
Nivel sonoro a 10m	dB(A)	23.2-32.4	23.4-32.8
Nivel sonoro a 1m	dB(A)	42-51.8	42.8-52
<b>* Dimensión / Peso</b>			
Peso neto	kg	130	135
Peso bruto	kg	148	150
Dimensión neta	mm	1113*519*1410	1113*519*1410
Dimensión de embalaje	mm	1225*540*1555	1225*540*1555

## 2. Descripción

UX11Csi32/UX14Csi32

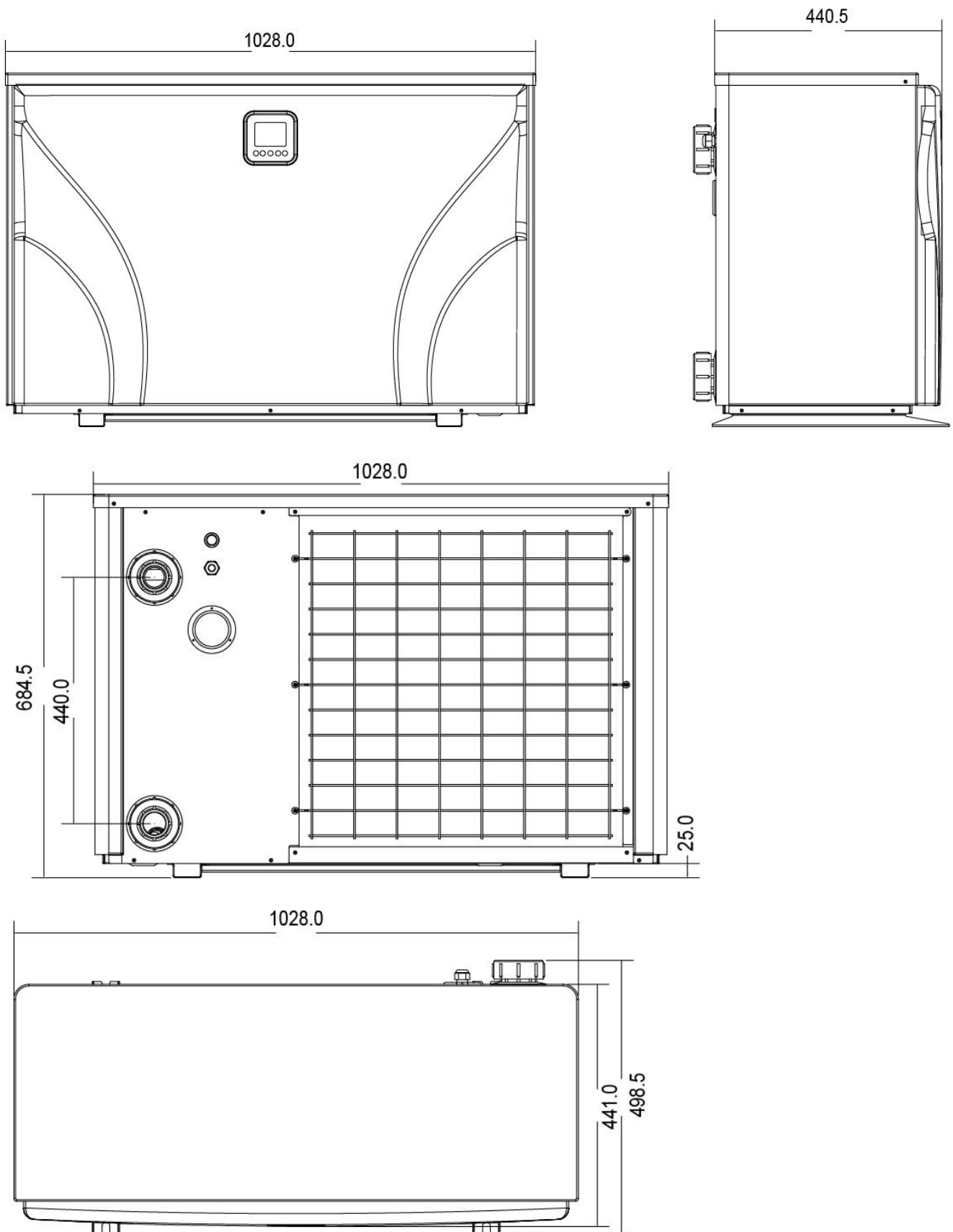

UX17Csi32/UX21Csi32

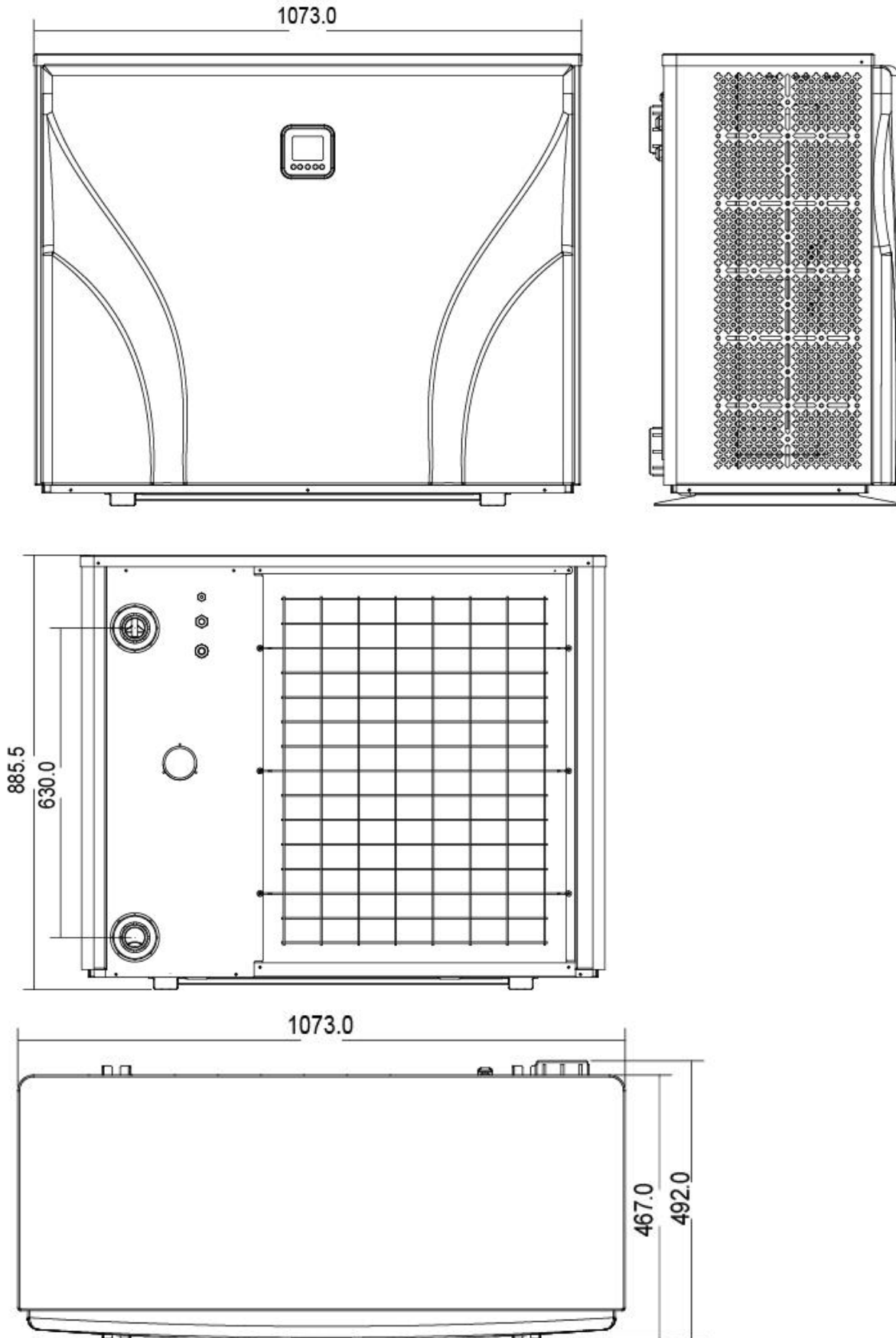

UX26Csi32

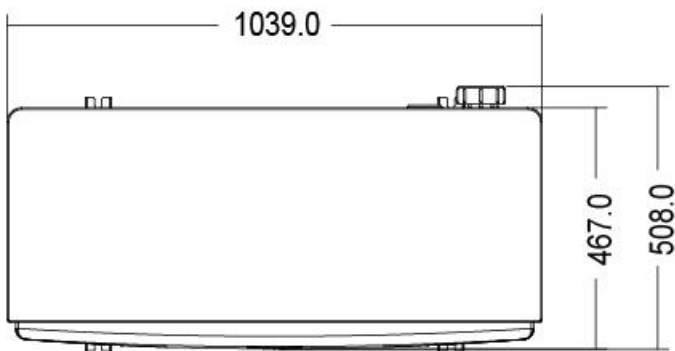
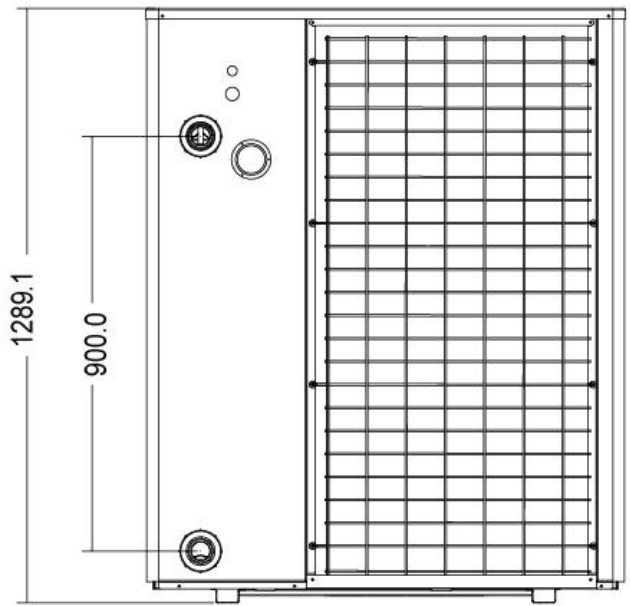
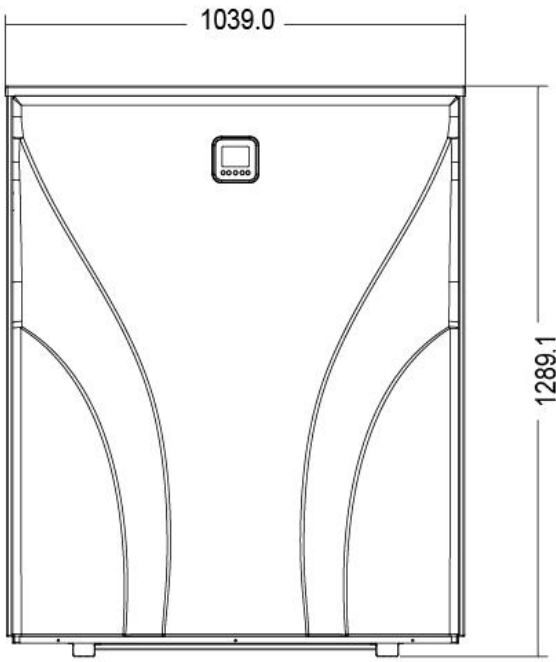

UX30Csi32/UX30Csi32T/UX35Csi32T

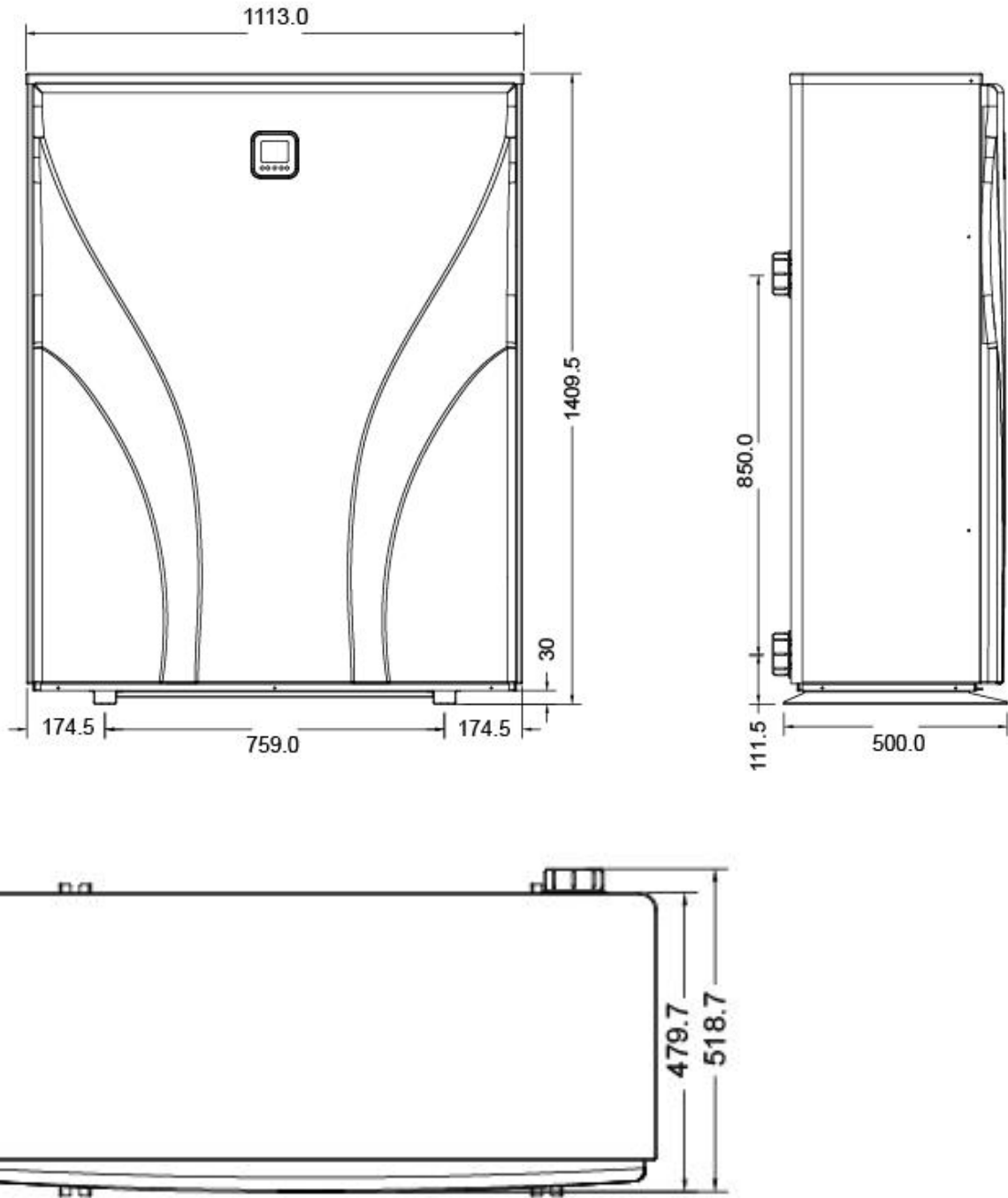

Unit: mm

### 3. Kit de Instalación

#### 3.1 Accesorios de instalación

	<p>Bases antivibratorias</p> <ol style="list-style-type: none"><li>1. Sacar 4 bases antivibratorias</li><li>2. Póngalos uno por uno en la parte inferior de la máquina.</li></ol>
	<p>Conexión de la pipeta de desagüe</p> <ol style="list-style-type: none"><li>1. Instale la pipeta de desagüe debajo del panel inferior</li><li>2. Conecte una tubería para drenar el agua.</li></ol> <p>Nota: Levante la bomba de calor para instalar la pipeta. Nunca vuelque la bomba de calor, podría dañar el compresor.</p>
	<p>Entrada y salida de agua</p> <ol style="list-style-type: none"><li>1. Instale las dos juntas como muestra la imagen</li><li>2. Enrosquelas en las tomas de agua.</li></ol> <p>Juntas de entrada y salida</p>
	<p>Cableado</p> <ol style="list-style-type: none"><li>1. Abra la caja del bornero (marcada en rojo) en el lado de la máquina</li><li>2. Conecte los cables de alimentación en las bornas como indica la imagen.</li></ol>



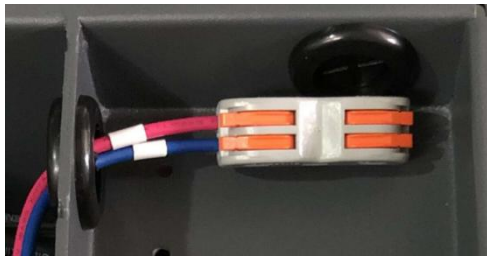

Conexión de la bomba de filtración  
(contacto libre de tensión)

1. Abra la caja bornas (marcada en rojo) en el lado de la máquina
2. Conecte los cables del sistema de filtración en las bornas, como indica la imagen.

### Connection to pilot the water pump

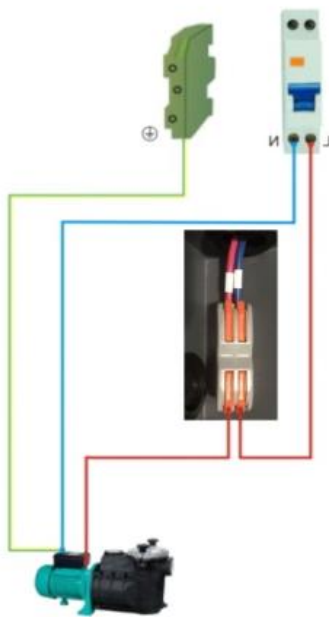
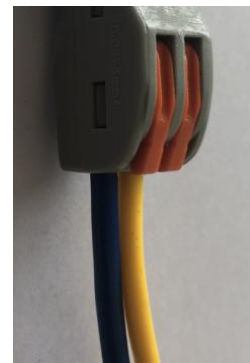
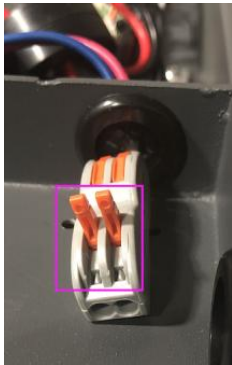

### **ATENCIÓN:**

Tenga en cuenta las siguientes reglas para la instalación de la bomba de calor:

1. Cualquier adición de productos químicos debe tener lugar en la tubería situada aguas abajo de la bomba de calor.
2. Siempre coloque la bomba de calor sobre una base sólida y nivelada. Utilice los soportes de goma incluidos para evitar la vibración y el ruido.
3. Mantenga siempre la bomba de calor en posición vertical. Si la unidad se ha trasladado con inclinación, espere por lo menos 24 horas antes de poner en marcha la bomba de calor.

### **3.2 Ubicación de la bomba de calor**

La unidad funcionará correctamente en cualquier lugar deseado siempre que los siguientes tres elementos estén presentes:

1. Aire fresco
2. Electricidad
3. Los filtros de la piscina

La unidad se puede instalar prácticamente en cualquier lugar al aire libre, siempre y cuando se mantengan las distancias mínimas especificadas a otros objetos (vea el dibujo de abajo). Por favor, consulte a su instalador para la instalación en una piscina cubierta. La instalación en un lugar ventoso no presenta ningún problema en, a diferencia con un calentador de gas.

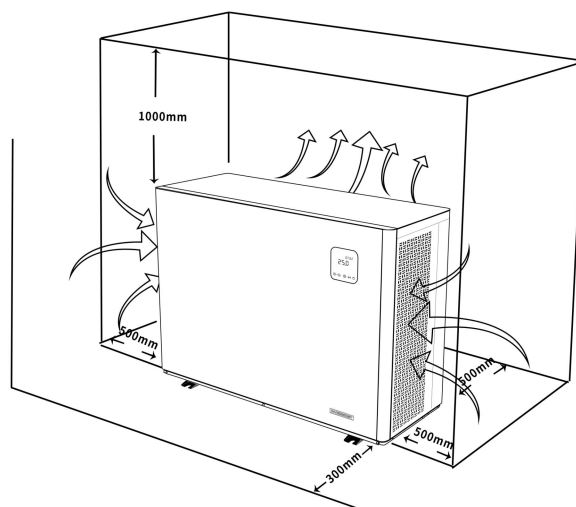

### 3.3 Distancia de su piscina

La bomba de calor normalmente se instala dentro de un área perimetral que se extiende a 7,5 m de la piscina. Cuanto mayor sea la distancia a la piscina, mayor será la pérdida de calor en las tuberías. Como las tuberías son en su mayoría subterráneas, la pérdida de calor es baja para distancias de hasta 30 m (15 m desde y hacia la bomba; 30 m en total) a menos que el suelo esté húmedo o el nivel del agua subterránea sea alto. Una estimación aproximada de la pérdida de calor por 30 m es de 0,6 kWh (2000 BTU) por cada 5 °C de diferencia entre la temperatura del agua de la piscina y la temperatura del suelo que rodea la tubería. Esto aumenta el tiempo de funcionamiento entre un 3% y un 5%.

### 3.4 Comprobar la válvula de la instalación

#### ▲ NOTA

Nota: Si se utiliza un equipo de dosificación automática para el cloro y la acidez (pH), es esencial para proteger la bomba de calor contra concentraciones químicas excesivamente altas que puedan corroer el intercambiador de calor. Por esta razón, un equipo de este tipo siempre debe instalarse en la tubería aguas abajo de la bomba de calor, y se recomienda instalar una válvula de retención para evitar el flujo inverso en la ausencia de circulación del agua.

El daño a la bomba de calor causado por el incumplimiento de esta instrucción no está cubierto por la garantía.

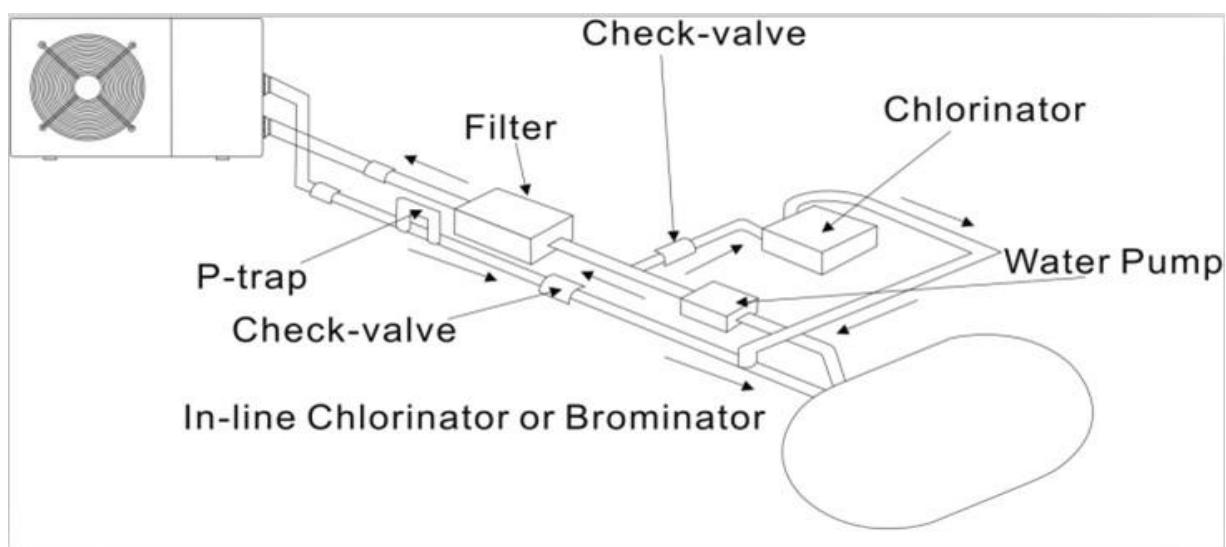

### 3.5 Disposición típica

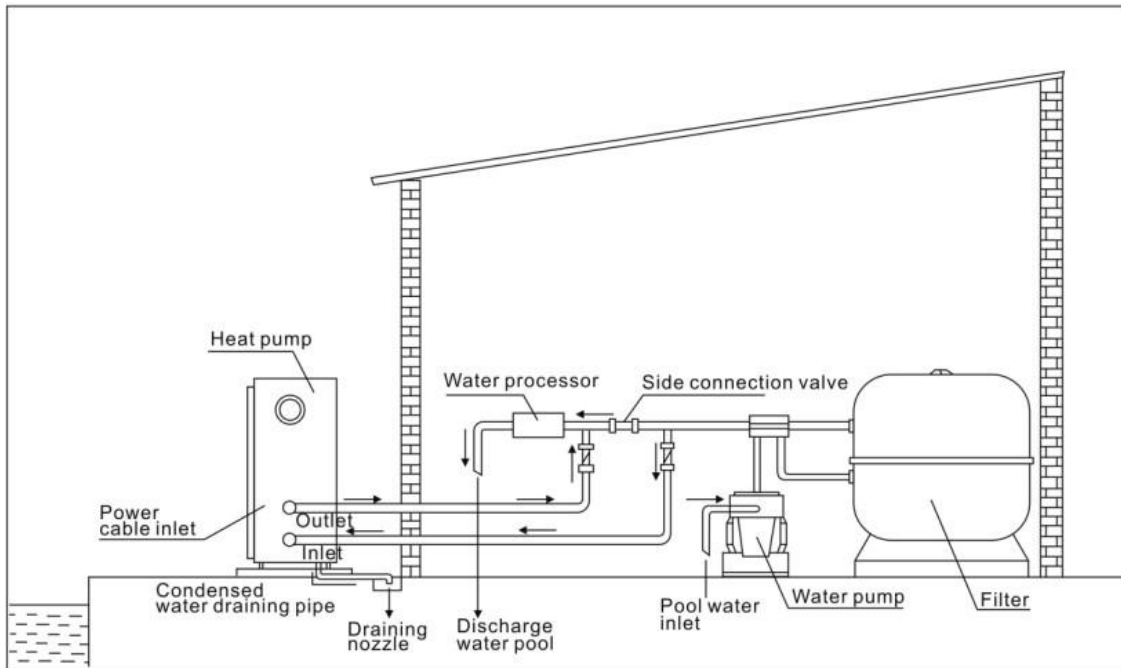

#### NOTA

De fábrica únicamente se suministra la bomba de calor. Todos los demás componentes, incluyendo una derivación si es necesaria, deben ser proporcionados por el usuario o el instalador.

#### ATENCIÓN:

Con el fin de calentar el agua de la piscina (o bañera de hidromasaje), la bomba de filtración debe estar en funcionamiento para hacer que el agua circule a través de la bomba de calor. La bomba de calor no arrancará si el agua no está circulando.

### 3.6 Puesta en funcionamiento

Después de que todas las conexiones se hayan hecho y comprobado, llevar a cabo el siguiente procedimiento:

1. Encienda la bomba de filtración, comprobar que no haya fugas y verifique que el agua fluye desde y hacia la piscina.

2. Conecte la alimentación de la bomba de calor y pulse el botón  de encendido / apagado en el panel de control LED. La unidad se pondrá en marcha después del tiempo de retardo (ver más abajo).

3. Después de unos minutos, comprobar si el aire que impulsa hacia fuera la unidad es más frío.

4. Cuando apague la bomba de filtración, la unidad también debe apagarse de forma automática, sino, a continuación, ajuste el interruptor de flujo.

5. Permita que la bomba de calor y la bomba de filtración funcionen las 24 horas del día hasta que se

alcance la temperatura deseada del agua. La bomba de calor se detendrá en este punto. Después de esto, se reiniciará automáticamente siempre que la filtración esté en funcionamiento y la temperatura del agua piscina desciende 2 grados por debajo de la temperatura establecida.

Dependiendo de la temperatura inicial del agua en la piscina y la temperatura del aire, puede tardar varios días en calentar el agua a la temperatura deseada. Una cubierta para la piscina puede reducir drásticamente el tiempo requerido.

### **3.7 Condensación**

El aire aspirado por la bomba de calor es fuertemente enfriado por la bomba de calor para calentar el agua de la piscina, este puede causar la condensación en las aletas del evaporador.

## 4. Ajuste del kit de derivación(No provisto)

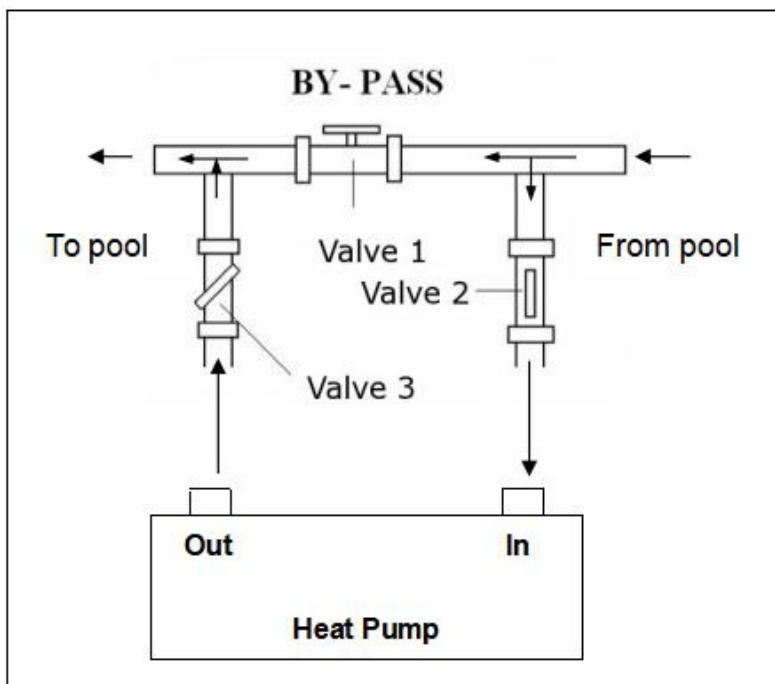

Utilice el siguiente procedimiento para ajustar la derivación:

1. abra completamente las tres válvulas
2. cierre lentamente la válvula 1 hasta que la presión del agua aumente en aproximadamente 100 a 200 g
3. Cierre la válvula 3

aproximadamente a la mitad para ajustar la presión del gas en el sistema de enfriamiento.

Si la pantalla muestra "ON" o el código de error EE03, cierre paso a paso la válvula 2, para aumentar el flujo de agua y deténgase cuando el código desaparezca.

El funcionamiento óptimo de la bomba de calor se produce cuando la presión del gas de refrigeración es de  $22 \pm 2$  bar.

Esta presión se puede leer en el manómetro junto al panel de control de la bomba de calor. En estas condiciones, el flujo de agua a través de la unidad también es óptimo.

**Nota:** La operación sin una derivación o con un ajuste de derivación inadecuado puede resultar en una operación subóptima de la bomba de calor y posiblemente dañar la bomba de calor, lo que anula la garantía.

Interruptor de flujo de agua:

Está equipado con un interruptor de flujo para proteger la unidad de HP funcionando con un caudal de agua adecuado. Se encenderá cuando la bomba de la piscina funcione y se apagará cuando la bomba se apague. Si el nivel del agua de la piscina es superior a 1 m por encima o por debajo de la perilla de ajuste automático de la bomba de calor, es posible que su distribuidor deba ajustar su puesta en marcha inicial.

**Retardo de tiempo:** la bomba de calor tiene un retardo de arranque incorporado de 3 minutos para proteger los circuitos y evitar un desgaste excesivo de los contactos. La unidad se reiniciará automáticamente después de que expire este tiempo de espera. Incluso una breve interrupción del suministro eléctrico activará este retraso y evitará que la unidad se reinicie inmediatamente. Las interrupciones de energía adicionales durante este período de retraso no afectan la duración de 3 minutos del retraso.

## 5. Funcionamiento del controlador

### 5.1. Guía de funcionamiento





Cuando la bomba de calor se conecta a la corriente, la pantalla LED muestra un código de 3 segundos que indica el modelo de la bomba de calor.

### 5.2 Las claves y sus operaciones

#### 5.2.1 Botón (icon)

Presione  para arrancar la bomba de calor, la pantalla de LED muestra la temperatura del agua deseada durante 5 segundos, luego muestra la temperatura del agua de entrada y el modo de operación.

Pulse  para detener la bomba de calor y muestre "OFF"

Aviso: Durante la comprobación y ajuste del parámetro, pulse la tecla  para salir rápidamente y guardar la configuración actual.

Pulse  de nuevo para encender / apagar la máquina.

#### 5.2.2 Botón (icon)

Presione  para cambiar el modo de trabajo, Turbo, inteligente y silencioso. El modo predeterminado es el modo inteligente.



Mientras elige el Turbo, la palabra "Turbo" se iluminará, la bomba de calor funcionará solo en "Salida completa".

Elija Smart, la palabra "Smart" se iluminará, la bomba de calor funcionará en "Salida media y máxima".

Elija Silencioso, la palabra "Silent" se encenderá, la bomba de calor funcionará en "Salida media y pequeña".

### 5.2.3 Botón

Hay 3 modos para la unidad, solo calefacción, modo automático (calefacción y enfriamiento), solo enfriamiento.

Presione  durante 5S para cambiar el modo de calentamiento , el modo de enfriamiento 

y el modo automático .

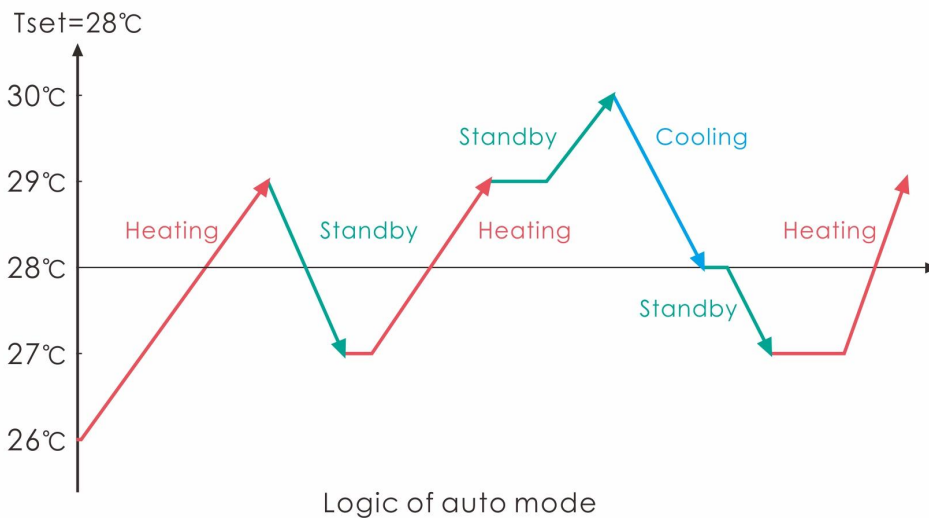

Observación: Al descongelar, el símbolo de calefacción parpadeará.

### Lógica de operación del modo automatic



### 5.2.4 Botón y

Bloquear / desbloquear la pantalla:



Mantenga  y  durante 5 segundos para bloquear / desbloquear la pantalla.

La pantalla se bloqueará automáticamente después de 30 segundos de espera. (cuando la pantalla está



bloqueada, el icono de  está encendido)

Ajuste de la temperatura del agua:

Pulse  o  para ajustar la temperatura del agua directamente.

Rango de ajuste del modo de calentamiento y del modo automático: 6-41 °C

Rango de ajuste del modo de enfriamiento: 6-35 °C

Comprobación de parámetros:

Pulse  primero, luego pulse  para comprobar el parámetro User de d0 a d14.

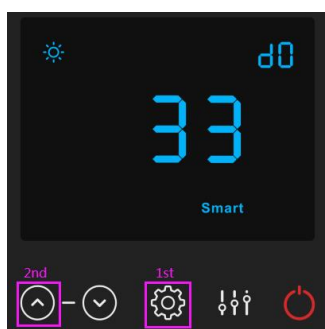

Código	Condición	Alcance	Observación
d0	IPM temperatura del molde	0-120°C	Valor de prueba real
d1	Temp. De agua de entrada T1	-9°C ~ 99°C	Valor de prueba real
d2	Temperatura del agua de salida T2	-9°C ~ 99°C	Valor de prueba real
d3	Temperatura ambiente. T5	-30°C ~ 70°C	Valor de prueba real
d4	Código de limitación de frecuencia	0,1,2,4,8,16	Valor de prueba real
d5	Temperatura Evaporador T3	-30°C ~ 70°C	Valor de prueba real
d6	Temperatura descarga de gas T6	0°C ~ C5°C (125°C)	Valor de prueba real
d7	Paso de EEV	0 ~ 99	N*5
d8	Frecuencia de funcionamiento del compresor	0 ~ 99Hz	Valor de prueba real
d9	Corriente del compresor	0 ~ 30A	Valor de prueba real
d10	Velocidad actual del ventilador	0-1200 (rpm)	Valor de prueba real
d11	Código de error de la última vez	Todo el código de error	

Observación: d4: código de limitación de frecuencia,

0: sin límite de frecuencia;

1: límite de temperatura de la tubería de la bobina;

2: límite de frecuencia de sobrecalentamiento o sobreenfriamiento;

- 4: límite de frecuencia actual de la unidad;
- 8: límite de frecuencia de tensión de accionamiento;
- 16: límite de frecuencia de alta temperatura de conducción

Pulse  primero, luego pulse  para comprobar / ajustar el parámetro de usuario de P1 a P18.

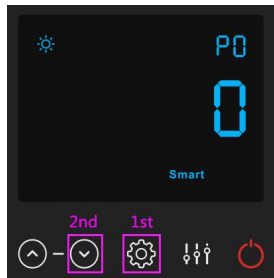







Código	Nombre	Alcance	Defecto	Observación
P0	Desescarche obligatorio	0-1	0	0: Operación normal predeterminada 1: Descongelamiento obligatorio.
P1	Modo de trabajo	0-1	1	1 Modo de calefacción, 0 modo de enfriamiento
P2	Temporizador activado / desactivado	0-1	0	1 El temporizador encendido / apagado está en función, 0 El temporizador encendido / apagado está fuera de funcionamiento (El ajuste de P5 y P6 no funcionará)
P3	Bomba de agua	0-1	0	1 Siempre en marcha, 0 Depende del funcionamiento del compresor
P4	Hora actual	HH:MM	0:00	<u>0-23:0-59</u>
P5	Temporizador en	HH:MM	0:00	<u>0-23:0-59</u>
P6	Temporizador desactivado	HH:MM	0:00	<u>0-23:0-59</u>
P7	Temp. De agua de entrada corrección	-9~9	0	Ajuste predeterminado: 0
P14	Reiniciar el sistema	0-1	0	1-Reiniciar el sistema 0-defecto (Reiniciar el sistema para P0, P1, P2, P3, P5, P6, P7, P8, P9, 10, P11)
P16	Código del producto	/	/	Depende de la maquina
P18	Mode	0-1	0	1—solo calefacción 0—calefacción/modo automático/enfriamiento.

Nota:

- 1). Mantenga presionado  durante 20 segundos para configurar P14, P16, P18.
- 2). El parámetro P8, P9, P10, P11, P19, P20 es solo para la configuración de fábrica.

### 5.2.5 Reiniciar el sistema

Presione , luego presione  para elegir P15 y mantenga presionado  durante 20 segundos para ingresar a la interfaz de configuración, en la que el parámetro parpadeará. Presione  o  para establecer el valor 1, finalmente presione  para guardar la configuración.

### 5.2.6 Botón (icon)

Símbolo de TIMER ON, la luz estará encendida cuando el valor de P2 sea 1, lo que significa que la función TIME ON & OFF está funcionando. Luego configure la hora actual (parámetro P4), TIMER ON (parámetro P5) y TIMER OFF (parámetro P6). Todos los símbolos (excepto el símbolo ) en la pantalla estarán apagados cuando el TEMPORIZADOR esté APAGADO.

Nota: El símbolo  permanece encendido cuando se reinicia la bomba de calor después del TIEMPO APAGADO, a menos que el valor de P2 se establezca en 0.

### 5.2.7 Prioridad de calefacción (ver el párrafo 6.9), opción de conexión

**Opción 1: La bomba de agua está relacionada con el funcionamiento de la bomba de calor para iniciar o detener.**

La bomba de agua arranca 60 s antes que el compresor, la bomba de agua arranca 30s y luego el interruptor de flujo de agua detecta caudal. Cuando la bomba de calor entra en modo de espera, el compresor se detendrá primero y la bomba de filtración se detendrá 5 minutos más tarde.

La bomba de filtración volverá a funcionar durante 5 minutos y luego se detendrá cuando el tiempo de espera sea superior a 1 horas.

	Condición	Ejemplo	Lógica de trabajo bomba de agua
Modo de calentamiento	$P3=0,$ $T1 \geq T_{set}-0.5^{\circ}\text{C},$ dura 30 minutos	$P3=0,$ $T1 \geq 27.5^{\circ}\text{C},$ dura 30 minutos	La bomba de agua entrará en el modo de espera durante 1 horas y no arrancará excepto que apague la fuente de alimentación y reinicie. La bomba de calor se reiniciará 5 minutos después de que la bomba de agua salga del modo de espera para detectar nuevamente la temperatura del agua T1.
Modo de enfriamiento	$P3=0,$ $T1 \leq T_{set}+0.5^{\circ}\text{C},$ dura 30 minutos	$P3=0,$ $T1 \leq 28.5^{\circ}\text{C},$ dura 30 minutos	La bomba de agua entrará en el modo de espera durante 1 horas y no arrancará excepto apague la fuente de alimentación y reinicie. La bomba de calor se reiniciará 5 minutos después de que la bomba de agua salga del modo de espera para detectar nuevamente la temperatura del agua T1.

#### **Opción 2 La bomba de filtración está siempre encendida (P3 = 1)**

Bajo la condición  $P3 = 1$ , cuando  $T1 \geq T_{set} + 1^{\circ}\text{C}$  ( $T1 \geq 29^{\circ}\text{C}$ ) dura 3 minutos, la bomba de calor estará en espera, mientras que la bomba de filtración está siempre encendida.

Si la bomba de calor se apaga manualmente o está TIMER OFF, la bomba de filtración se detendrá en consecuencia.

En la opción 2, con activación del temporizador;  $P2 = 1$  para iniciar y detener la bomba de filtración de acuerdo con la programación de P4 (tiempo), P5 (temporizador activado) y P6 (temporizador desactivado)

#### **Condición para el arranque de la bomba de calor, temporizador activado;**

Cuando el temporizador alcanza el tiempo establecido de TEMPORIZADOR ENCENDIDO, la bomba de filtración arrancará y después de 5 minutos comenzará la bomba de calor. La bomba de calor permanece parada si la temperatura del agua es  $\geq T_{set} + 1^{\circ}\text{C}$  ( $T1 \geq 29^{\circ}\text{C}$ ), antes de que el TEMPORIZADOR APAGADO, la filtración aún esté activada.

#### **Condición para detener la bomba de calor, temporizador OFF activo;**

Cuando el temporizador alcanza el tiempo establecido del TEMPORIZADOR APAGADO, la bomba de calor se detendrá y después de 5 minutos se detiene la bomba de filtración.

#### **NOTA :**

$T_{set}$  = temperatura establecida del agua

Por ejemplo:  $T_{set}=28^{\circ}\text{C}$ . Temperatura establecida del agua en la bomba de calor de su piscina.

$T_{set}-0.5$  = menos  $0.5^{\circ}\text{C}$  que la temperatura establecida;  $T_{set}- 0.5 = 28-0.5 = 27.5^{\circ}\text{C}$

$T_{set} + 0.5$  = más  $0.5^{\circ}\text{C}$  que la temperatura establecida;  $T_{set} + 0.5 = 28 + 0.5 = 28.5^{\circ}\text{C}$

### 5.3 Lógica para calefacción

Estado de trabajo		Modo de trabajo	Agua en temperatura-T1	Por ejemplo, Agua en temperatura-T1	Bomba de calor nivel de trabajo
1	Puesta en marcha de bomba de calor	Cuando seleccionas el "modo Smart"	$T1 < Tset-1$	$T1 < 27^{\circ}C$	Modo Powerful- frecuencia F9
2			$Tset-1 \leq T1 < Tset$	$27^{\circ}C \leq T1 < 28^{\circ}C$	Frecuencia: F9-F8-F7, ..., - F2
3			$Tset \leq T1 < Tset+1$	$28^{\circ}C \leq T1 < 29^{\circ}C$	Modo Silent- frecuencia F2
4			$T1 \geq Tset+1$	$T1 \geq 29^{\circ}C$	Bomba de calor estará en modo de espera y dejará de funcionar hasta que la temperatura del agua disminuya a $28^{\circ}C$ .
5		Al seleccionar el "Modo Silent"	$T1 < Tset$	$T1 < 28^{\circ}C$	Modo Smart -Frecuencia F5.
6			$Tset \leq T1 < Tset+1$	$28^{\circ}C \leq T1 < 29^{\circ}C$	Modo Silent-frecuencia F2 / F1.
7			$T1 \geq Tset+1$	$T1 \geq 29^{\circ}C$	Bomba de calor estará en modo de espera y dejará de funcionar hasta que la temperatura del agua caiga a menos de $28^{\circ}C$ .
8		Cuando seleccionas el "Modo Powerful"	$T1 < Tset+1$	$T1 < 29^{\circ}C$	Modo Powerfu-frecuencia F10/F9
9			$T1 \geq Tset+1$	$T1 \geq 29^{\circ}C$	Bomba de calor estará en modo de espera y dejará de funcionar hasta que la temperatura del agua disminuya a $28^{\circ}C$ .
10	Reiniciar para calentar el agua en estado de espera	Cuando Bomba de calor está trabajando en "Modo Smart"	$T1 \geq Tset$	$T1 \geq 28^{\circ}C$	En espera
11			$Tset > T1 \geq Tset-1$	$28^{\circ}C > T1 \geq 27^{\circ}C$	Silent- frecuencia F2
12			$Tset-1 > T1 \geq Tset-2$	$27^{\circ}C > T1 \geq 26^{\circ}C$	Frecuencia: F2-F3-F4, ..., - F9
13		Cuando Bomba de calor está trabajando en "Modo Silent"	$< Tset-2$	$< 26^{\circ}C$	Powerful-frecuencia F9
14			$\geq Tset$	$\geq 28^{\circ}C$	En espera
15			$Tset > T1 \geq Tset-1$	$28^{\circ}C > T1 \geq 27^{\circ}C$	Modo Silent-frecuencia F2 / F1
16			$T1 < Tset-1$	$T1 < 27^{\circ}C$	Smart-frecuencia F5
17	Cuando Bomba de calor está trabajando en "Modo Powerful"	$T1 < Tset-1$	$T1 < 27^{\circ}C$	Powerful -frecuencia F10 / F9	

#### 5.4 Lógica de operación de enfriamiento

Estado de trabajo		Modo de trabajo	Agua en temperatura-T1	Por ejemplo, Agua en temperatura-T1	Bomba de calor nivel de trabajo
1	Puesta en marcha de bomba de calor	Cuando seleccionas el "Modo Smart"	$T1 \cong Tset-1$	$T1 \cong 27^{\circ}C$	En espera
2			$Tset-1 < T1 \cong Tset$	$27^{\circ}C < T1 \cong 28^{\circ}C$	Modo Silent-frecuencia F2
3			$Tset < T1 \cong Tset+1$	$28 < T1 \cong 29^{\circ}C$	Frecuencia: F9 -F8-F7,...,- F2
4			$T1 \cong Tset+1$	$T1 \cong 29^{\circ}C$	Modo Powerful-F9
5		Al seleccionar el "Modo Silent"	$T1 \cong Tset-1$	$\cong 27^{\circ}C$	En espera
6			$Tset-1 < T1 \cong Tset$	$27^{\circ}C < T1 \cong 28^{\circ}C$	Modo Silent- frecuencia F2/F1
7			$T1 > Tset$	$T1 > 28^{\circ}C$	Modo Smart -frecuencia F5
8		Cuando seleccionas el "Modo Powerful"	$T1 > Tset-1$	$T1 > 27^{\circ}C$	Modo Powerful-frecuencia F10/F9
9			$T1 \cong Tset-1$	$T1 \cong 27^{\circ}C$	En espera
10	Reiniciar para enfriar el agua en estado de espera	Smart	$T1 \cong Tset-1$	$T1 \cong 27^{\circ}C$	En espera
11			$Tset \cong T1 < Tset+1$	$28 \cong T1 < 29^{\circ}C$	Modo Silent- frecuencia F2
12			$Tset+1 \cong T1 < Tset+2$	$29 \cong T1 < 30^{\circ}C$	Frecuencia: F2 -F3-F4,...,- F9
13			$T1 \cong Tset+2$	$T1 \cong 30^{\circ}C$	Modo Powerful -frecuencia F9
14		Silent	$Tset < T1 \cong Tset+1$	$28 < T1 \cong 29^{\circ}C$	Modo Silent-frecuencia F2/F1
15			$T1 > Tset+1$	$T1 > 29^{\circ}C$	Modo Smart-frecuencia F5
16		Powerful	$T1 > Tset+1$	$T1 > 29^{\circ}C$	Modo Powerful-frecuencia F10/F9
17			$T1 \cong Tset-1$	$T1 \cong 27^{\circ}C$	En espera

## 6. Solución de Problemas

### 6.1 Visualización del código de error en el controlador LED

Mal funcionamiento	Código de error	Razón	Solución
Fallo en el sensor de temperatura de entrada del agua d1-TH6	PP01	1. El sensor en circuito abierto o cortocircuito 2. El cableado del sensor está suelto	1. Verifique o cambie el sensor 2. Reparar el cableado de los sensores
Fallo en el sensor de temperatura de salida del agua d2-TH5	PP02	1.El sensor en circuito abierto o cortocircuito 2. El cableado del sensor está suelto	1. Verifique o cambie el sensor 2. Reparar el cableado de los sensores
Fallo en la sonda del evaporador d5-TH2	PP03	1. El sensor en circuito abierto o cortocircuito 2. El cableado del sensor está suelto	1. Verifique o cambie el sensor 2. Reparar el cableado de los sensores
Falla del sensor de temperatura ambiental d3-TH1	PP05	1. El sensor en circuito abierto o cortocircuito 2. El cableado del sensor está suelto	1. Verifique o cambie el sensor 2. Reparar el cableado de los sensores
Fallo del sensor de temperatura de descarga del compresor d6-TH3	PP06	1. El sensor en circuito abierto o cortocircuito 2. El cableado del sensor está suelto	1. Verifique o cambie el sensor 2. Reparar el cableado de los sensores
Protección antihielo en invierno	PP07	La temperatura ambiente o la temperatura de entrada del agua es demasiado baja	Protección normal
Protección de baja temperatura ambiente	PP08	1. Fuera del rango de funcionamiento por baja temperatura 2. Anormalidad del sensor	1. Dejar de usar, más allá del límite de temperatura 2. Cambie el sensor
Protección contra temperatura del condensador. Demasiado alta en modo enfriar d5-TH2	PP10	1. La temperatura del ambiente es demasiado alta o la temperatura del agua es demasiado alta en el modo de enfriamiento 2. El sistema de refrigeración es anormal	1. Compruebe el alcance de uso 2. Revise el sistema de refrigeración
Protección de temperatura de agua. Muy baja en modo frío d2-TH5	PP11	1. Bajo flujo de agua 2. Sensor de temperatura d2-TH5 anormal	1. Revisar la bomba de agua y el sistema de filtración 2. Cambie el sensor de temperatura d2-TH5

<b>Mal funcionamiento</b>	<b>Código de error</b>	<b>Razón</b>	<b>Solución</b>
Fallo de alta presión TS4	EE01	<ol style="list-style-type: none"> <li>1. Minipresostato de alta presión en mal conectado o falla</li> <li>2. La temperatura ambiente es demasiado alta</li> <li>3. La temperatura del agua es demasiado alta</li> <li>4. El flujo de agua es demasiado bajo</li> <li>5. La velocidad del motor del ventilador es anormal o el motor del ventilador está dañado</li> </ol>	<ol style="list-style-type: none"> <li>1. Compruebe el cableado del minipresostato de alta presión o cambielo</li> <li>2. Revise el flujo de agua o la bomba de filtración</li> <li>3. Compruebe el motor del ventilador</li> <li>4. Revisar y reparar el sistema de filtración</li> </ol>
Fallo de baja presión TS5	EE02	<ol style="list-style-type: none"> <li>1. Minipresostato de baja presión mal conectado o falla</li> <li>2. EEV está bloqueada o el sistema de tuberías está atascado</li> <li>3. La velocidad del motor es anormal o el motor esta dañado</li> <li>4. Fuga de gas</li> </ol>	<ol style="list-style-type: none"> <li>1. Compruebe el cableado del Minipresostato de baja presión o cambielo</li> <li>2. Compruebe la EEV y el sistema de tuberías. Compruebe el motor.</li> <li>3. Mediante el manómetro de alta presión compruebe el valor de la presión</li> <li>4. Comprobar el sistema de refrigeración</li> </ol>
No hay flujo de agua o fallo del Minipresostato de flujo de agua TS1	EE03 Or" ON"	<ol style="list-style-type: none"> <li>1. El Minipresostato de flujo de agua está mal conectado</li> <li>2. No hay flujo de agua insuficiente</li> </ol>	<ol style="list-style-type: none"> <li>1. Comprobar el cableado del Minipresostato de flujo de agua o cambiarlo.</li> <li>2. Compruebe la bomba de filtración o el circuito de agua</li> </ol>
Protección de temperatura del agua demasiado alta en modo calentar d2-TH5	EE04	<ol style="list-style-type: none"> <li>1. Bajo flujo de agua</li> <li>2. El Minipresostato de flujo de agua está atascado y el suministro de agua está cortado</li> <li>3. Sensor d2-TH5 es anormal</li> </ol>	<ol style="list-style-type: none"> <li>1. Compruebe el circuito de agua</li> <li>2. Compruebe la bomba de filtración o el Minipresostato de flujo de filtración</li> <li>3. Compruebe el sensor d2-TH5 o cambielo</li> </ol>
Temperatura de descarga del compresor demasiado alta d6-TH3	EE05	<ol style="list-style-type: none"> <li>1. Falta de gas</li> <li>2. Bajo flujo de agua</li> <li>3. Circuito frigorífico</li> <li>4. Fallo del sensor</li> </ol>	<ol style="list-style-type: none"> <li>1. Compruebe el manómetro de alta presión, si es demasiado bajo, llénelo con un poco de gas</li> <li>2. Compruebe el circuito frigorífico y la bomba de filtración</li> <li>3. Compruebe el sistema de tuberías si hubiera alguna obstrucción</li> <li>4. Cambiar sonda de descarga.</li> </ol>



<b>Mal funcionamiento</b>	<b>Código de error</b>	<b>Razón</b>	<b>Solución</b>
Fallo de controlador o fallo de comunicación	EE06	<ol style="list-style-type: none"> <li>1. La conexión no es buena o está dañado el cable.</li> <li>2. Controlador averiado.</li> </ol>	<ol style="list-style-type: none"> <li>1. Compruebe y vuelva a conectar el cable</li> <li>2. Cambiar por cable</li> <li>3. Apague el suministro eléctrico y reinicie la máquina</li> <li>4. Cambiar a nuevo controlador</li> </ol>
Protección de consumo del compresor	EE07	<ol style="list-style-type: none"> <li>1. La corriente del compresor es demasiado alta</li> <li>2. Error en la secuencia de la fase del compresor</li> <li>3. Acumulación de líquido y/o aceite en el compresor hacen que el consumo sea mayor.</li> <li>4. Compresor o placa de control dañada</li> <li>5. El flujo de agua es anormal fluctuaciones</li> </ol>	<ol style="list-style-type: none"> <li>1. Compruebe el compresor</li> <li>2. Compruebe el sistema frigorífico</li> <li>3. Compruebe si la potencia instalada es un rango normal.</li> <li>4. Compruebe la conexión de secuencia de fases</li> </ol>
Error de comunicación entre el controlador y la placa principal	EE08	<ol style="list-style-type: none"> <li>1. Poca señal de conexión o cable de señal dañado</li> <li>2. Mal funcionamiento del controlador</li> </ol>	<ol style="list-style-type: none"> <li>1. Compruebe y vuelva a conectar el cable de señal</li> <li>2. Cambiar el cable de señal</li> <li>3. Apague el suministro eléctrico y reinicie la máquina</li> <li>4. Cambiar el controlador</li> </ol>
Error de comunicación entre la placa principal y la placa del controlador	EE09	<ol style="list-style-type: none"> <li>1. Mala o cable de comunicación</li> <li>2. El cable está dañado</li> </ol>	<ol style="list-style-type: none"> <li>1. Compruebe la conexión del cable</li> <li>2. Cambiar el cable</li> </ol>
Protección VDC. Tensión demasiado alta	EE10	<ol style="list-style-type: none"> <li>1. La tensión de la línea es demasiado alta</li> <li>2. Placa dañada</li> </ol>	<ol style="list-style-type: none"> <li>1. Compruebe si la potencia está en el rango normal</li> <li>2. Cambie la placa</li> </ol>
Protección del módulo IPM	EE11	<ol style="list-style-type: none"> <li>1. Error de datos</li> <li>2. Conexión de fases del compresor incorrecta</li> <li>3. Acumulación de líquido en el compresor</li> <li>4. Mala disipación de calor del módulo de accionamiento o temperatura ambiente alta</li> <li>5. Compresor o placa dañado</li> </ol>	<ol style="list-style-type: none"> <li>1. Error en el programa, apagar el suministro de electricidad y reiniciar después de 3 minutos</li> <li>2. Verifique la conexión de la secuencia del compresor</li> <li>3. Verifique la presión del sistema con un manómetro</li> <li>4. Compruebe si la temperatura ambiente y del agua es demasiado alta</li> <li>5. Cambiar la placa</li> </ol>

<b>Mal funcionamiento</b>	<b>Código de error</b>	<b>Razón</b>	<b>Solución</b>
Protección de bajo voltaje de VDC	EE12	<ol style="list-style-type: none"> <li>1. La tensión de la línea es demasiado baja</li> <li>2. La placa está dañado.</li> </ol>	<ol style="list-style-type: none"> <li>1. Compruebe si la potencia está en el rango normal</li> <li>2. Cambiar la placa de control</li> </ol>
Protección de sobreintensidad	EE13	<ol style="list-style-type: none"> <li>1. La corriente del compresor es demasiado grande momentáneamente</li> <li>2. El flujo de agua es anormal</li> <li>3. Fluctuaciones de energía en un corto espacio de tiempo</li> <li>4. Inductor PFC incorrecto</li> </ol>	<ol style="list-style-type: none"> <li>1. Compruebe el compresor</li> <li>2. Compruebe el sistema frigorífico</li> <li>3. Compruebe si la potencia está en el rango normal</li> <li>4. Compruebe si se utiliza el inductor PFC correcto</li> </ol>
Error de salida del circuito de detección de temperatura del módulo IPM	EE14	<ol style="list-style-type: none"> <li>1. Salida anormal del circuito térmico del módulo IPM</li> <li>2. Motor del ventilador dañado o funcionamiento anormal.</li> <li>3. La hoja de ventilador está rota</li> </ol>	<ol style="list-style-type: none"> <li>1. Cambiar placa</li> <li>2. Compruebe si la velocidad del motor es demasiado baja o si el motor del ventilador está dañado, cambielo</li> <li>3. Cambiar la hoja de ventilador</li> </ol>
Temperatura del módulo IPM demasiado alta	EE15	<ol style="list-style-type: none"> <li>1. Excepción de salida del circuito térmico del módulo IPM</li> <li>2. Motor del ventilador dañado o funcionamiento anormal.</li> <li>3. La hoja de ventilador está rota</li> </ol>	<ol style="list-style-type: none"> <li>1. Cambiar placa</li> <li>2. Compruebe si la velocidad del motor del ventilador es demasiado baja o si el motor del ventilador está dañado, cambielo</li> <li>3. Cambiar otra hoja de ventilador</li> </ol>
Protección del módulo PFC	EE16	<ol style="list-style-type: none"> <li>1. Excepción de salida del módulo PFC</li> <li>2. Motor del ventilador dañado o funcionamiento anormal.</li> <li>3. La hoja de ventilador está rota</li> <li>4. Salto de voltaje de entrada, la potencia de entrada es anormal</li> </ol>	<ol style="list-style-type: none"> <li>1. Cambiar placa</li> <li>2. Compruebe si la velocidad del motor es demasiado baja o si el motor del ventilador está dañado, cambielo</li> <li>3. Cambiar la hoja del ventilador</li> <li>4. Comprobar la tensión de entrada</li> </ol>
Fallo motor del ventilador DC	EE17	<ol style="list-style-type: none"> <li>1. El motor DC está dañado</li> <li>2. Para la trifásica, verifique si el neutro está conectado</li> <li>3. El controlador está dañado</li> <li>4. La hoja del ventilador está atascada</li> </ol>	<ol style="list-style-type: none"> <li>1. Fallo del motor DC, sustituya por uno nuevo.</li> <li>2. Compruebe la conexión del cableado de la máquina trifásica</li> <li>3. Verifique la placa, reemplace una nueva placa de conducción del motor del ventilador o la placa principal si hay una falla</li> <li>4. Compruebe si hay alguna barrera delante de la aspa del ventilador y retírela</li> </ol>
Función anormal del modulo PFC	EE18	La placa de control está dañada	<ol style="list-style-type: none"> <li>1. Cambiar una nueva palca</li> <li>2. Compruebe si la velocidad del motor del ventilador es demasiado baja o si el motor del ventilador está dañado, cambielo</li> </ol>

<b>Mal funcionamiento</b>	<b>Código de error</b>	<b>Razón</b>	<b>Solución</b>
Fallo por alta temperatura del modulo PFC	EE19	<ol style="list-style-type: none"> <li>1. Salida del circuito térmico del módulo PFC anormal</li> <li>2. Motor del ventilador dañado o funcionamiento anormal.</li> <li>3. La hoja del ventilador está rota</li> <li>4. La conexión en la placa de control no está bien conectada</li> </ol>	<ol style="list-style-type: none"> <li>1. Cambiar el controlador</li> <li>2. Compruebe si la velocidad del motor es demasiado baja o si el motor del ventilador está dañado, cambielo</li> <li>3. Cambiar la hoja del ventilador</li> <li>4. Verifique si la conexión está suelta</li> </ol>
Error de alimentación de entrada	EE20	El voltaje de la fuente de alimentación fluctúa demasiado	Compruebe si el voltaje es estable
Error en el control del software	EE21	<ol style="list-style-type: none"> <li>1. El compresor se queda sin comunicación</li> <li>2. Programa incorrecto</li> <li>3. Impurezas dentro del compresor hace que la velocidad de rotación sea inestable</li> </ol>	<ol style="list-style-type: none"> <li>1. Compruebe o cambie el controlador</li> <li>2. Introduzca el programa correcto</li> </ol>
Error de circuito de detección de corriente	EE22	<ol style="list-style-type: none"> <li>1. Señal de tensión anormal</li> <li>2. El controlador está dañado</li> <li>3. Falla de la placa principal</li> </ol>	<ol style="list-style-type: none"> <li>1. Cambiar una nueva placa principal</li> <li>2. Cambiar una nueva placa de controlador</li> </ol>
Fallo de arranque del compresor	EE23	<ol style="list-style-type: none"> <li>1. El controlador está dañado</li> <li>2. Error de cableado del compresor o contacto deficiente o desconectado</li> <li>3. Acumulación de líquido en el compresor</li> <li>4. Conexión de fase incorrecta para el compresor</li> </ol>	<ol style="list-style-type: none"> <li>1. Compruebe o cambie el controlador</li> <li>2. Compruebe el cableado del compresor de acuerdo con el diagrama de circuito</li> </ol> <p>Compruebe el compresor o cambielo</p>
Fallo del dispositivo de temperatura ambiente en la placa electrónica	EE24	Fallo del dispositivo de temperatura ambiente	Cambiar la placa del controlador o la placa principal
Falla de fase del compresor	EE25	Mala conexión de las fases	Compruebe el cableado actual de acuerdo con el diagrama de circuito
Error en la válvula de 4 vías	EE26	<ol style="list-style-type: none"> <li>1. Fallo de la válvula de cuatro vías</li> <li>2. Falta de refrigerante (no detecta d5-TH2 o d3-TH1 )</li> </ol>	<ol style="list-style-type: none"> <li>1. Conmutar al modo de refrigeración para comprobar si la válvula de 4 vías se ha invertido correctamente</li> <li>2. Cambiar la válvula de 4 vías</li> <li>3. Llenar con gas</li> </ol>
Error de lectura de datos EEPROM	EE27	<ol style="list-style-type: none"> <li>1. Datos de la EPROM incorrectos en el programa o fallo en la entrada de datos de la EPROM</li> <li>2. Fallo de la placa principal</li> </ol>	<ol style="list-style-type: none"> <li>1. Introduzca los datos correctos de la EEPROM</li> <li>2. Cambiar la placa principal</li> </ol>
Falla de comunicación en el chip interno de la placa electrónica	EE28	Fallo en la placa principal	<ol style="list-style-type: none"> <li>1. Apague el suministro eléctrico y vuelva a encenderlo</li> <li>2. Cambiar la placa principal</li> </ol>

**Observaciones:**

1. En el modo de calefacción, si la temperatura de salida del agua es más alta que la temperatura establecida , en más de 7°C,, el controlador LED muestra EE04 para la protección del sobrecalentamiento del agua.
2. En el modo de enfriamiento, si la temperatura de salida del agua es más baja que la temperatura establecida , en más de 7°C, el controlador LED muestra PP11 para la protección de sobrecalentamiento del agua.

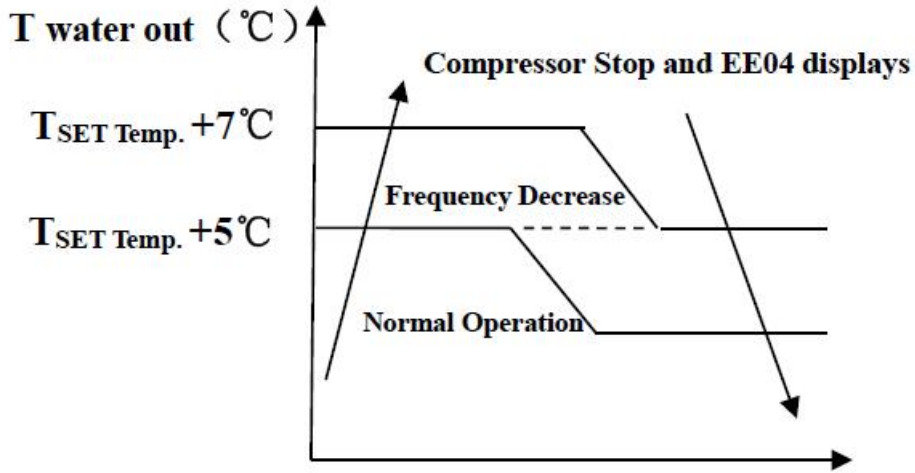

**Protección contra sobrecalentamiento de agua EE04**

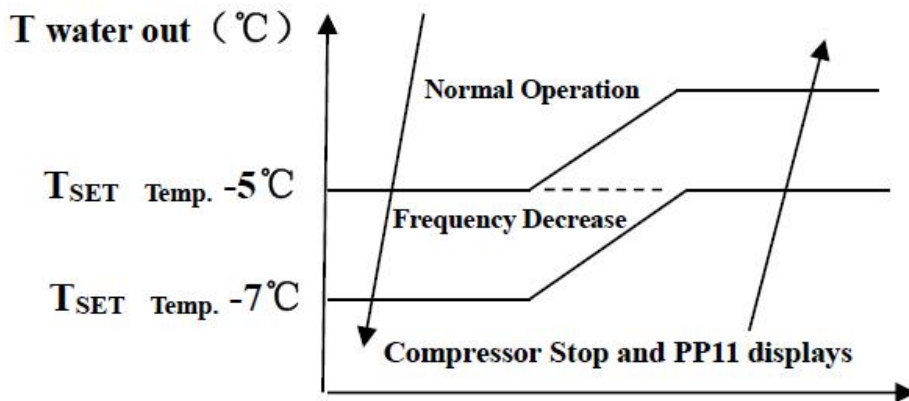

**Protección de sobreenfriamiento de agua PP11**

Por ejemplo, como a continuación:

Modo	Temperatura salida del agua	Temperatura Set Point	Condición	Mal funcionamiento
Modo de calentamiento	36°C	29°C	$T_{out} - T_{set} \cong 7^{\circ}\text{C}$	EE04 Protección contra sobrecalentamiento para la temperatura del agua (d2- TH5)
Modo de enfriamiento	23°C	30°C	$T_{set} - T_{out} \cong 7^{\circ}\text{C}$	PP11 Protección demasiado baja para la temperatura del agua (d2- TH5)

## 6.2 Otras Averías y Soluciones ( No display en controlador LED)

Aavería	Descripción	Motivos	Solución
La bomba de calor no está funcionando	Ninguna visualización en el display del controlador LED.	No hay alimentación de potencia.	Chequee el cable e interruptor, verifique si están conectados.
	Controlador LED muestra el tiempo actual	La bomba de calor está en el estado standby.	Inicie la bomba de calor para su puesta en marcha.
	El controlador LED muestra la temperatura del agua actual.	1. La temperatura del agua está llegando al valor de ajuste, la bomba de calor se encuentra en estado de temperatura constante. 2. La bomba de calor comienza justo a funcionar. 3. Bajo descongelación.	1. Verifica el ajuste de la temperatura del agua. 2. Inicie la bomba de calor después de algunos minutos. 3. El controlador LED debe mostrar "descongelación".
La temperatura del agua se enfría cuando la bomba de calor funciona en el modo calefacción.	El controlador LED muestra la temperature actual del agua y el código de error.	1. Elección del modo incorrecto. 2. Las cifras muestran un problema. 3. Fallo del controlador.	1. Ajuste el modo para un buen funcionamiento. 2. Reemplace el controlador LED de fallo, y luego chequee el estado después de haber cambiado el modo de funcionamiento, verifique la temperatura de entrada y salida del agua. 3. Reemplace o repare la unidad de la bomba de calor.
Funcionamiento corto	LED muestra la temperature actual del agua, no se muestra el código de error.	1. Ventilador NO funciona. 2. La ventilación del aire no es suficiente. 3. El refrigerante no es suficiente.	1. Chequee las conexiones de cable entre el motor y el ventilador, si es necesario, deben ser reemplazados. 2. Compruebe la ubicación de la unidad de la bomba de calor, y elimine todos los obstáculos para tener una buena ventilación del aire. 3. Reemplace o repare la unidad de la bomba del calor.
Manchas de agua	Manchas de agua en la unidad de la bomba de calor	1. Protección 2. Fuga del agua.	1. Ninguna acción. 2. Verifique con cuidado el intercambiador de calor de titanio si hay algún fallo de fuga.
Demasiado hielo en el evaporador	Demasiado hielo en el evaporador		1. Chequee la ubicación de la unidad de la bomba de calor, y elimine todos los obstáculos para tener una buena ventilación del aire. 2. Reemplace o repare la unidad de la bomba de calor.





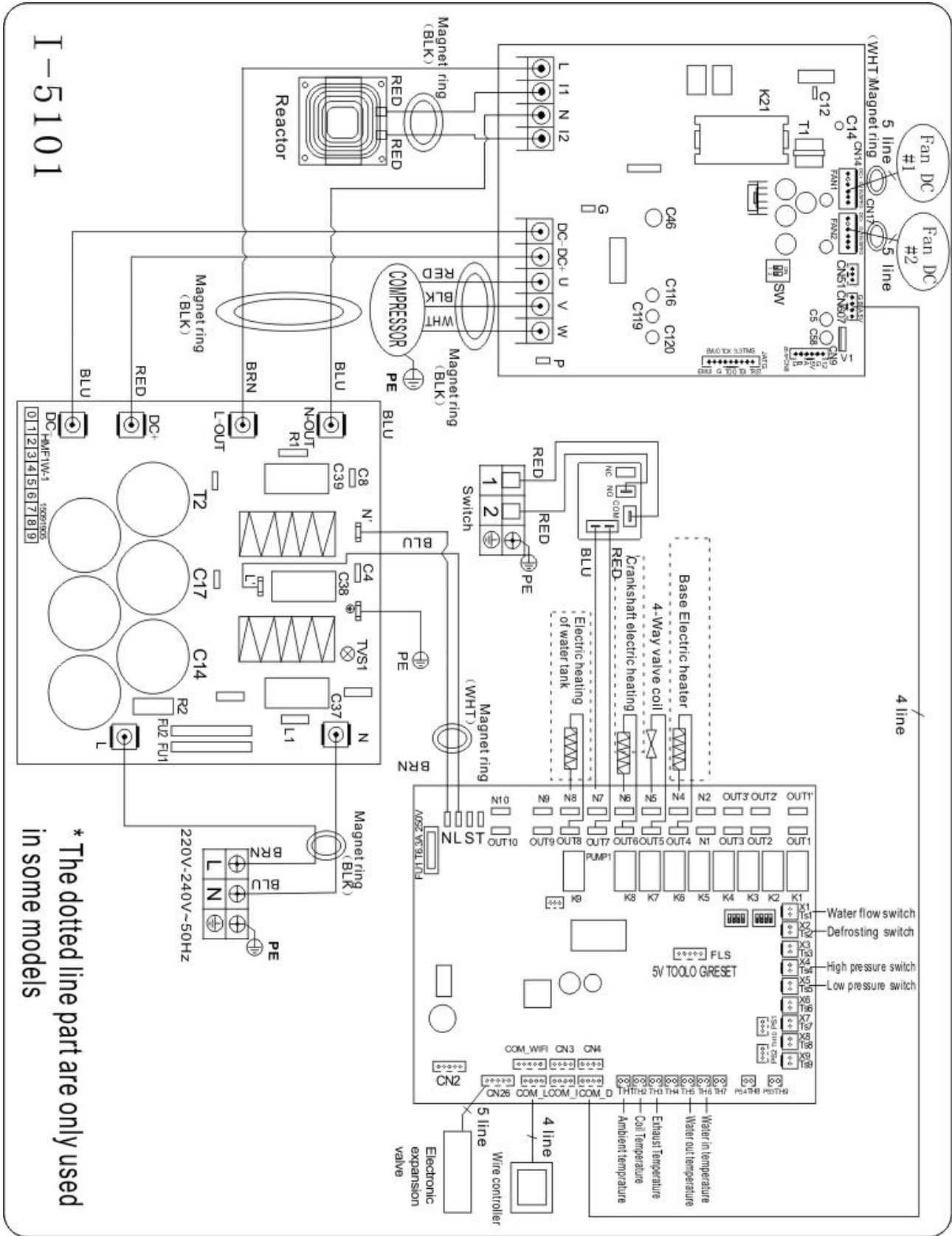

I-5101

\* The dotted line part are only used in some models





cableado.

(2) La bomba de calor de la piscina debe estar bien conectada a tierra, aunque el intercambiador de calor de la unidad está eléctricamente aislado del resto de la unidad. Aún es necesario conectar la unidad a tierra para protegerlo contra cortocircuitos dentro de la unidad. .

Desconexión: Un medio de desconexión (disyuntor, interruptor con o sin fusible) debe estar ubicado a la vista y fácilmente accesible desde la unidad. Esta es una práctica común en las bombas de calor comerciales y residenciales. Evita la activación remota de equipos desatendidos y permite apagar la unidad mientras se realiza el mantenimiento.

## **8. Mantenimiento**

(1) Debe verificar el sistema de suministro de agua con regularidad para evitar que entre aire en el sistema y que se produzca un flujo de agua bajo, ya que reduciría el rendimiento y la confiabilidad de la unidad HP.

(2) Limpie sus piscinas y sistema de filtración con regularidad para evitar daños en la unidad como resultado de la suciedad o el filtro obstruido.

(3) Debe descargar el agua del fondo de la bomba de agua si la unidad HP deja de funcionar durante mucho tiempo (especialmente durante la temporada de invierno).

(4) De otra manera, debe verificar que la unidad esté completamente llena de agua antes de que comience a funcionar nuevamente.

(5) Después de acondicionar la unidad para la temporada de invierno, se recomienda cubrir la bomba de calor con una bomba de calor de invierno especial.

(6) Cuando la unidad está funcionando, siempre hay una pequeña descarga de agua debajo de la unidad.

# 9. Diagrama de despiece

UX11Csi32/UX14Csi32

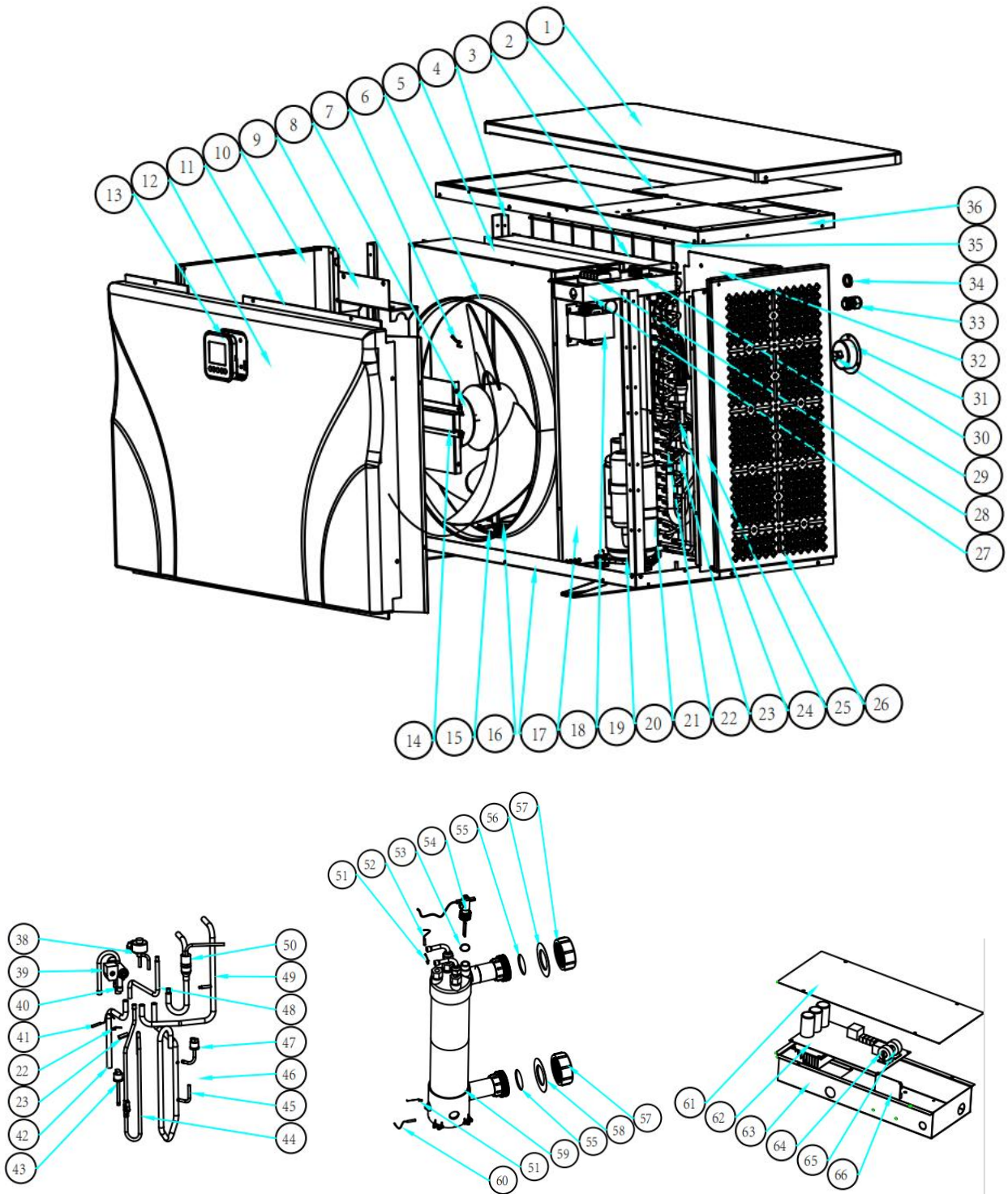

**UX11Csi32**

NO.	ERP	Part name	NO.	ERP	Part name
1	109060056	Tapa superior	34	136020119	Agujero de paso de cable
2	109060053	Panel de servicio	35	109060017	Parrilla trasera
3	103000335	Evaporador	36	109060051	Marco superior
4	109060052	Pilar	37	119000058	EEV
5	109060023	Panel de ventilador	38	121000037	Bobina de válvula de 4 vías
6	117110063	Sonda Tª ambiente d3-TH1	39	121000034	Válvula de 4 vías
7	132000015	Aspa del ventilador	40	117110050	Sonda evaporador. Desescarche. d5-TH2
8	112000031	Motor del ventilador	41	113060188	Tubería
9	109060027	Soporte del motor del ventilador	42	116000066	Minipresostato de alta presión
10	109060058	Panel izquierdo	43	113020623	Tubería
11	109060042	Panel de servicio	44	113020579	Tubería
12	133470001	Panel frontal	45	/	Tubería
13	117020293	Control	46	116000071	Minipresostato de baja presión
14	109060054	Pilar	47	113080123	Tubería
15	109060004	Placa de soporte del evaporador	48	113030214	Tubería
16	142000142	Resistencia de calentamiento del evaporador	49	113070067	Tubería
17	109060050	Bandeja de base	50	108010025	Clip
18	109060059	Panel de aislamiento	51	117110057	Sonda Tª salida de agua sensor d2-TH5
19	117230003	Reactor	52	136010072	Anillo de goma en la conexión de agua
20	101000188	Compresor	53	116000103	Interruptor de flujo de agua
21	142000072	Resistencia de calentamiento del compresor	54	133020007	Cubierta de PVC
22	113190007	Clip	55	133020012	Anillo de goma rojo
23	113190001	Alojamiento de sonda	56	102050004	Conjuntos de conexión de agua
24	117110061	Sonda Tª descarga sensor d6-TH3	57	133020012	Anillo de goma rojo
25	109060044	Panel de servicio	58	102041113	Intercambiador de calor de titanio
26	109060057	Panel derecho	59	117110053	Sonda Tª de entrada de agua. sensor d1-TH6
27	108960058	Caja de cableado	60	109060007	Tapa de caja eléctrica
28	115000004	Terminal de potencia	61	117100079	PCB
29	136010004	Clip	62	109060039	Caja eléctrica
30	124020011	Tornillo	63	117240002	Anillo magnético
31	106000012	Manómetro	64	117240003	Anillo magnético
32	109060055	Panel trasero	65	117010122	Módulo wifi
33	110000039	Conector del cable			

**UX14Csi32**

NO.	ERP	Part name	NO.	ERP	Part name
1	109060056	Tapa superior	34	136020119	Agujero de paso de cable
2	109060053	Panel de servicio	35	109060017	Parrilla trasera
3	103000335	Evaporador	36	109060051	Marco superior
4	109060052	Pilar	37	119000058	EEV
5	109060023	Panel de ventilador	38	121000037	Bobina de válvula de 4 vías
6	117110063	Sonda Tª ambiente d3-TH1	39	121000034	Válvula de 4 vías
7	132000015	Aspa del ventilador	40	117110050	Sonda evaporador. Desescarche. d5-TH2
8	112000031	Motor del ventilador	41	113060188	Tubería
9	109060027	Soporte del motor del ventilador	42	116000066	Minipresostato de alta presión
10	109060058	Panel izquierdo	43	113020623	Tubería
11	109060042	Panel de servicio	44	113020693	Tubería
12	133470001	Panel frontal	45	/	Tubería
13	117020293	Control	46	116000071	Minipresostato de baja presión
14	109060054	Pilar	47	113080123	Tubería
15	109060004	Placa de soporte del evaporador	48	113030214	Tubería
16	142000142	Resistencia de calentamiento del evaporador	49	113070067	Tubería
17	109060050	Bandeja de base	50	108010025	Clip
18	109060059	Panel de aislamiento	51	117110057	Sonda Tª salida de agua sensor d2-TH5
19	117230003	Reactor	52	136010072	Anillo de goma en la conexión de agua
20	101000188	Compresor	53	116000103	Interruptor de flujo de agua
21	142000072	Resistencia de calentamiento del compresor	54	133020007	Cubierta de PVC
22	113190007	Clip	55	133020012	Anillo de goma rojo
23	113190001	Alojamiento de sonda	56	102050004	Conjuntos de conexión de agua
24	117110061	Sonda Tª descarga sensor d6-TH3	57	133020012	Anillo de goma azul
25	109060044	Panel de servicio	58	102041138	Intercambiador de calor de titanio
26	109060057	Panel derecho	59	117110053	Sonda Tª de entrada de agua. sensor d1-TH6
27	108960058	Caja de cableado	60	109060007	Tapa de caja eléctrica
28	115000004	Terminal de potencia	61	117100076	PCB
29	136010004	Clip	62	109060039	Caja eléctrica
30	124020011	Tornillo	63	117240002	Anillo magnético
31	106000012	Manómetro	64	117240003	Anillo magnético
32	109060055	Panel trasero	65	117010122	Módulo wifi
33	110000039	Conector del cable			



**UX17Csi32**

NO.	ERP	Part name	NO.	ERP	Part name
1	108960050	Tapa superior	35	110000036	Conector del cable
2	108960057	Marco superior	36	108960053	Panel de servicio
3	108840091	Parrilla trasera	37	/	/
4	108960061	Panel de ventilador	38	121000037	Bobina de válvula de 4 vías
5	136010004	Clip	39	121000034	Válvula de 4 vías
6	115000004	Terminal de potencia	40	113060208	Tubería
7	108960037	Pilar	41	113010440	Tubería
8	117230003	Reactor	42	117110050	Sonda evaporador. Desescarche. d5-TH2
9	132000023	Aspa del ventilador	43	116000067	Minipresostato de alta presión
10	112000031	Motor del ventilador	44	/	/
11	117110063	Sonda Tª ambiente d3-TH1	45	/	Tubería
12	108960060	Soporte del motor del ventilador	46	116000073	Minipresostato de baja presión
13	108960073	Panel izquierdo	47	113020673	Tubería
14	133450001	Panel frontal	48	113080128	Tubería
15	117020293	Control	49	113030212	Tubería
16	108960062	Panel de servicio	50	119000058	EEV
17	108960052	Pilar	51	113070065	Tubería
18	108960074	Bandeja de base	52	/	#N/A
19	108960002	Placa de soporte del evaporador	53	108010025	Clip
20	108960063	Panel de aislamiento	54	117110057	Sonda Tª salida de agua sensor d2-TH5
21	101000181	Compresor	55	136010072	Anillo de goma en la conexión de agua
22	142000074	Resistencia de calentamiento del compresor	56	116000065	Interruptor de flujo de agua
23	142000142	Resistencia de calentamiento del evaporador	57	133020007	Cubierta de PVC
24	108960065	Panel de servicio	58	133020012	Anillo de goma rojo
25	108960072	Panel derecho	59	102050004	Conjuntos de conexión de agua
26	113190001	Alojamiento de sonda	60	133020011	Anillo de goma azul
27	113190007	Clip	61	102041110	Intercambiador de calor de titanio
28	117110061	Sonda Tª descarga sensor d6-TH3	62	117110053	Sonda Tª de entrada de agua. sensor d1-TH6
29	106000012	Manómetro	63	108960007	Tapa de caja eléctrica
30	108960058	Caja de cableado	64	117100076	PCB
31	103000360	Evaporador	65	108960054	Caja eléctrica
32	108960075	Panel trasero	66	117240002	Anillo magnético
33	110000048	Conector del cable	67	117240003	Anillo magnético
34	110000039	Conector del cable	68	117010122	Módulo wifi

UX21Csi32

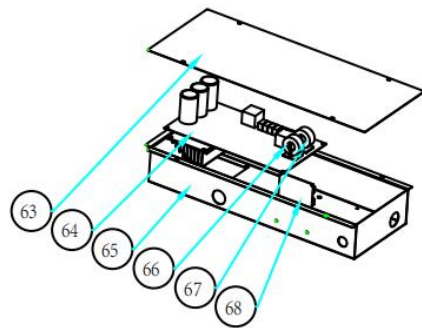
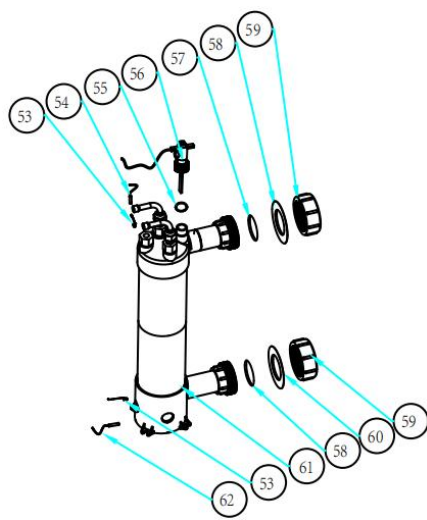
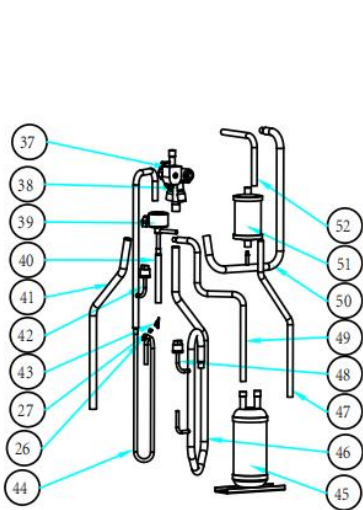
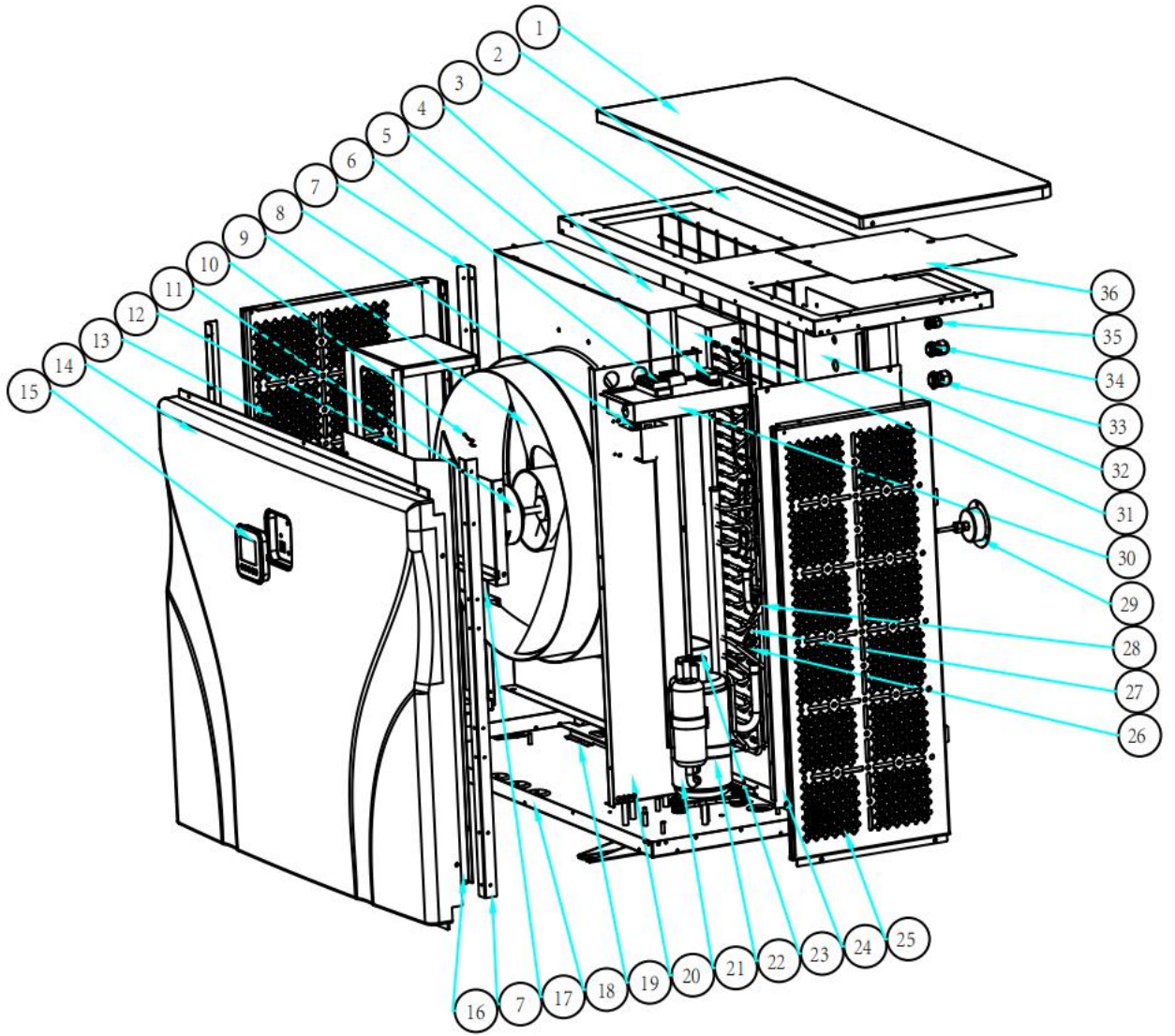



**UX21Csi32**

NO.	ERP	Part name	NO.	ERP	Part name
1	108960050	Tapa superior	35	110000036	Conector del cable
2	108960057	Marco superior	36	108960053	Panel de servicio
3	108840091	Parrilla trasera	37	121000028	Válvula de 4 vías
4	108960061	Panel de ventilador	38	121000037	Bobina de válvula de 4 vías
5	136010004	Clip	39	119000066	EEV
6	115000004	Terminal de potencia	40	113080128	Tubería
7	108960037	Pilar	41	113060193	Tubería
8	117230003	Reactor	42	116000068	Minipresostato de alta presión
9	132000023	Aspa del ventilador	43	117110050	Sonda evaporador. Desescarche. d5-TH2
10	112000031	Motor del ventilador	44	113010434	Tubería
11	117110063	Sonda Tª ambiente d3-TH1	45	105000004	Tanque de almacenamiento de líquidos
12	108960060	Soporte del motor del ventilador	46	113020683	Tubería
13	108960073	Panel izquierdo	47	113130041	Tubería
14	133450001	Panel frontal	48	116000073	Minipresostato de baja presión
15	117020293	Control	49	113120065	Tubería
16	108960062	Panel de servicio	50	113030216	Tubería
17	108960052	Pilar	51	120000066	Filtro deshidratador
18	108960079	Bandeja de base	52	113170079	Tubería
19	108960002	Placa de soporte del evaporador	53	108010025	Clip
20	108960063	Panel de aislamiento	54	117110057	Sonda Tª salida de agua sensor d2-TH5
21	101000252	Compresor	55	136010072	Anillo de goma en la conexión de agua
22	142000072	Resistencia de calentamiento del compresor	56	116000065	Interruptor de flujo de agua
23	142000142	Resistencia de calentamiento del evaporador	57	133020007	Cubierta de PVC
24	108960065	Panel de servicio	58	133020012	Anillo de goma rojo
25	108960072	Panel derecho	59	102050004	Conjuntos de conexión de agua
26	113190001	Alojamiento de sonda	60	133020011	Anillo de goma azul
27	113190007	Clip	61	102041110	Intercambiador de calor de titanio
28	117110061	Sonda Tª descarga sensor d6-TH3	62	117110053	Sonda Tª de entrada de agua. sensor d1-TH6
29	106000012	Manómetro	63	108960007	Tapa de caja eléctrica
30	108960058	Caja de cableado	64	117100076	PCB
31	103000337	Evaporador	65	108960054	Caja eléctrica
32	108960075	Panel trasero	66	117240002	Anillo magnético
33	110000048	Conector del cable	67	117240003	Anillo magnético
34	110000039	Conector del cable	68	117010122	Módulo wifi

UX26Csi32

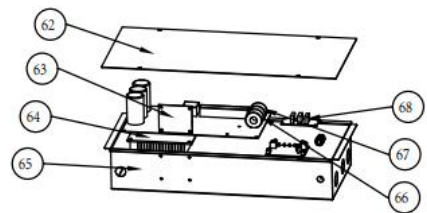
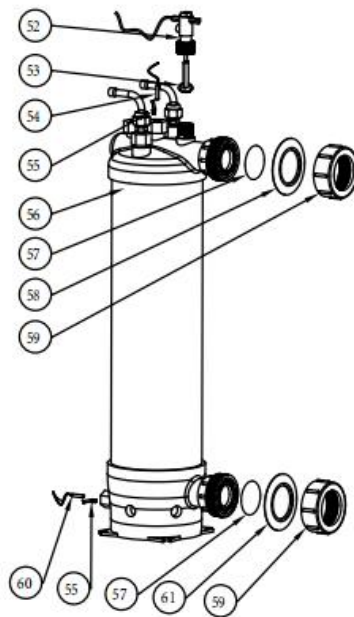
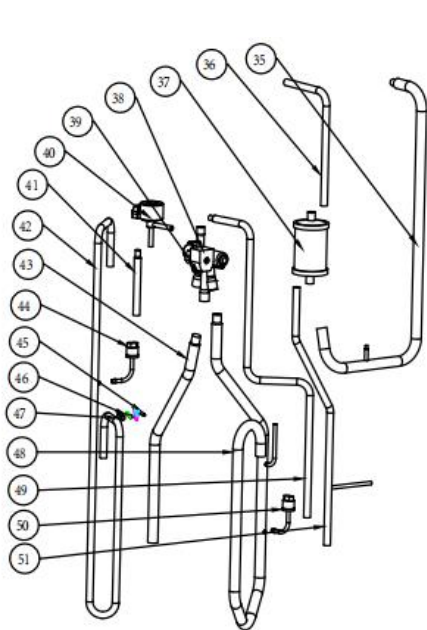
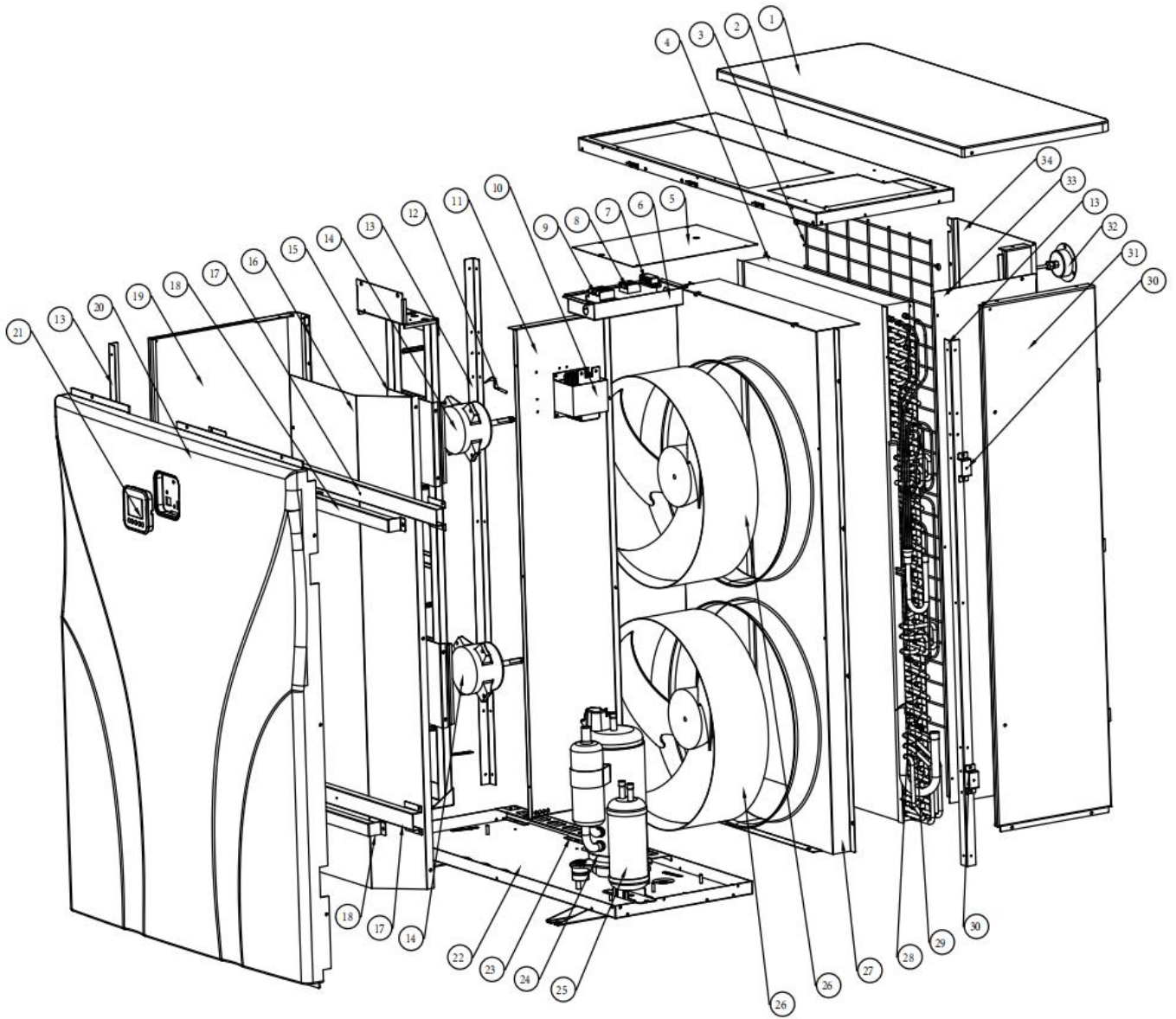

**UX26Csi32**

NO.	ERP	Part name	NO.	ERP	Part name
1	108940051	Tapa superior	35	113030215	Tubería
2	108940059	Marco superior	36	113170078	Tubería
3	108940012	Parrilla trasera	37	120000066	Filtro deshidratador
4	103000354	Evaporador	38	121000037	Bobina de válvula de 4 vías
5	108940034	Panel de servicio	39	121000028	Válvula de 4 vías
6	108960058	Caja de cableado	40	119000059	EEV
7	136010004	Clip	41	113080116	Tubería
8	115000012	Terminal de potencia	42	113020621	Tubería
9	115000025	Terminal de potencia	43	113060211	Tubería
10	117230002	Reactor	44	116000068	Minipresostato de alta presión
11	108940060	Panel de aislamiento	45	117110051	Sonda Tª descarga sensor d6-TH3
12	117110063	Sonda Tª ambiente d3-TH1	46	113190007	Clip
13	108940047	Pilar	47	113190001	Alojamiento de sonda
14	112000031	Motor del ventilador	48	113020703	Tubería
15	108940016	Soporte del motor del ventilador	49	113130040	Tubería
16	108940035	Panel de servicio	50	116000073	Minipresostato de baja presión
17	108940048	Pilar	51	113120063	Tubería
18	108960081	Pilar	52	116000065	Interruptor de flujo de agua
19	108940057	Panel izquierdo	53	136010089	Anillo de goma en la conexión de agua
20	133480002	Panel frontal	54	117110057	Sonda Tª salida de agua sensor d2-TH5
21	117020293	Control	55	108010025	Clip
22	108940043	Bandeja de base	56	102041127	Intercambiador de calor de titanio
23	108940004	Placa de soporte del evaporador	57	133020007	Cubierta de PVC
24	101000185	Compresor	58	133020012	Anillo de goma rojo
25	105000015	Tanque de almacenamiento de líquidos	59	102050004	Conjuntos de conexión de agua
26	132000015	Aspa del ventilador	60	117110053	Sonda Tª de entrada de agua. sensor d1-TH6
27	108940056	Panel de ventilador	61	133020011	Anillo de goma azul
28	117110050	Sonda evaporador. Desescarche. d5-TH2	62	108940062	Tapa de caja eléctrica
29	136020005	Bloque de goma	63	117010122	Módulo wifi
30	109070064	Pilar	64	117100077	PCB
31	108940058	Panel derecho	65	108940061	Caja eléctrica
32	106000012	Manómetro	66	117240002	Anillo magnético
33	108940036	Panel de servicio	67	117240003	Anillo magnético
34	108940053	Panel trasero	68	117010081	Clip

UX30Csi32/UX30Csi32T/UX35Csi32T

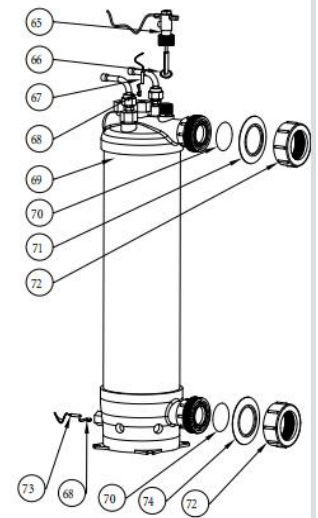
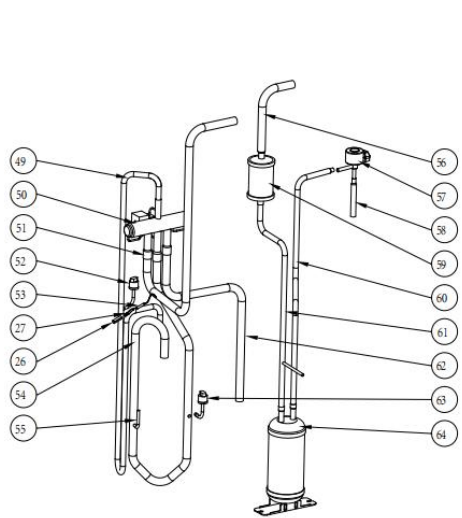
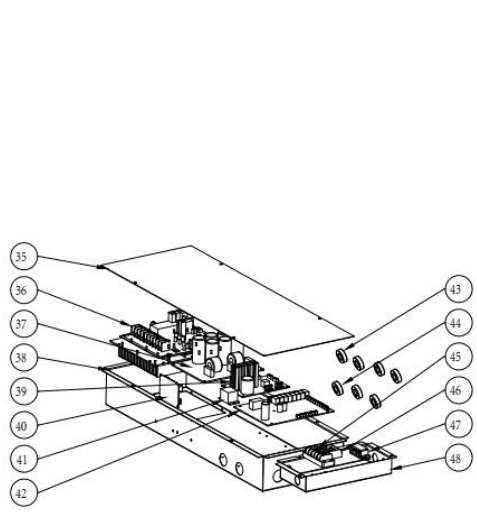
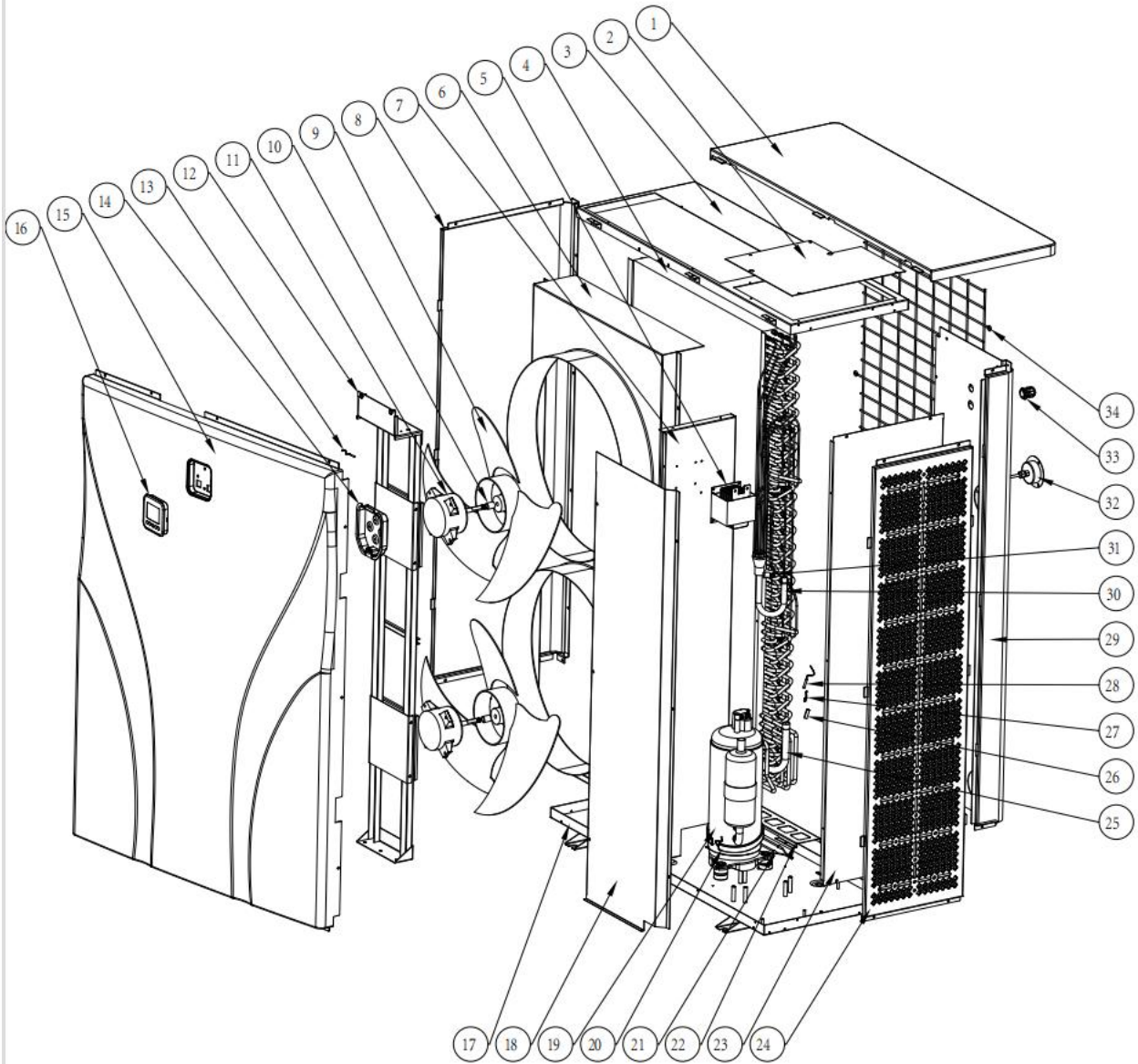

**UX30Csi32**

NO.	ERP	Part name	NO.	ERP	Part name
1	109070060	Tapa superior	38	109070006	Caja electrica
2	109070052	Panel de servicio	39	/	/
3	109070051	Marco superior	40	117010122	Módulo wifi
4	103000331	Evaporador	41	142000038	Relé
5	117230002	Reactor	42	117250021	PCB
6	109070019	Panel de ventilador	43	117240002	Anillo magnético
7	109070026	Panel de aislamiento	44	117240003	Anillo magnético
8	109070057	Panel izquierdo	45	115000025	Terminal de potencia
9	132000023	Aspa del ventilador	46	115000023	Terminal de potencia
10	108010024	Ensamblaje del motor del ventilador	47	136010004	Clip
11	112000031	Motor del ventilador	48	108960058	Caja de cableado
12	109070021	Soporte del motor del ventilador	49	113010444	Tubería
13	117110063	Sonda Tª ambiente d3-TH1	50	121000028	Válvula de 4 vías
14	133030020	Caja de control	51	113030183	Tubería
15	133460001	Panel frontal	52	116000068	Minipresostato de alta presion
16	117020293	Control	53	117110051	Sonda Tª descarga sensor d6-TH3
17	109070065	Bandeja de base	54	113020684	Tubería
18	109070053	Panel de servicio	55	113020685	Tubería
19	101000185	Compresor	56	113070061	Tubería
20	142000077	Resistencia de calentamiento del compresor	57	119000061	EEV
21	142000079	Resistencia de calentamiento del evaporador	58	113080116	Tubería
22	109070004	Placa de soporte del evaporador	59	120000066	Filtro deshidratador
23	109070054	Panel de servicio	60	113120053	Tubería
24	109070058	Panel derecho	61	113130039	Tubería
25	103000331	Tubería	62	113060214	Tubería
26	113190001	Alojamiento de sonda	63	116000073	Minipresostato de baja presión
27	113190007	Clip	64	105000015	Tanque de almacenamiento de líquidos
28	117110050	Sonda evaporador. Desescarche. d5-TH2	65	116000065	Interruptor de flujo de agua
29	109070062	Panel trasero	66	136020083	Anillo de goma en la conexión de agua
30	103000331	Tubería	67	117110057	Sonda Tª salida de agua sensor d2-TH5
31	136020005	Bloque de goma	68	108010025	Clip
32	106000012	Manómetro	69	102041106	Intercambiador de calor de titanio
33	110000038	Conector del cable	70	133020006	Anillo de goma en conexión de agua
34	109070022	Parrilla trasera	71	133020012	Anillo de goma rojo
35	109070007	Tapa de caja electrica	72	102050004	Conjuntos de conexión de agua
36	117140016	Placa de controlador trifásica	73	117110053	Sonda Tªde entrada de agua. sensor d1-TH6
37	117260001	Tablero de filtro	74	133020011	Anillo de goma azul

**UX30Csi32T**

NO.	ERP	Part name	NO.	ERP	Part name
1	109070060	Tapa superior	38	109070006	Caja electrica
2	109070052	Panel de servicio	39	/	/
3	109070051	Marco superior	40	117010122	Módulo wifi
4	103000331	Evaporador	41	142000038	Relé
5	117230002	Reactor	42	117250022	PCB
6	109070019	Panel de ventilador	43	117240002	Anillo magnético
7	109070068	Panel de aislamiento	44	117240003	Anillo magnético
8	109070070	Panel izquierdo	45	115000006	Terminal de potencia
9	132000023	Aspa del ventilador	46	115000023	Terminal de potencia
10	108010024	Ensamblaje del motor del ventilador	47	136010004	Clip
11	112000031	Motor del ventilador	48	108960058	Caja de cableado
12	109070021	Soporte del motor del ventilador	49	113020636	Tubería
13	117110063	Sonda Tª ambiente d3-TH1	50	121000028	Válvula de 4 vías
14	133030020	Caja de control	51	113030183	Tubería
15	133460001	Panel frontal	52	116000068	Minipresostato de alta presion
16	117020293	Control	53	117110051	Sonda Tª descarga sensor d6-TH3
17	180060001	Bandeja de base	54	113020697	Tubería
18	109070069	Panel de servicio	55	/	Tubería
19	101000239	Compresor	56	113070061	Tubería
20	142000077	Resistencia de calentamiento del compresor	57	119000061	EEV
21	142000079	Resistencia de calentamiento del evaporador	58	113080116	Tubería
22	109070004	Placa de soporte del evaporador	59	120000066	Filtro deshidratador
23	109070066	Panel de servicio	60	113120053	Tubería
24	109070058	Panel derecho	61	113130039	Tubería
25	103000331	Tubería	62	113060214	Tubería
26	113190001	Alojamiento de sonda	63	116000073	Minipresostato de baja presión
27	113190007	Clip	64	105000015	Tanque de almacenamiento de líquidos
28	117110050	Sonda evaporador. Desescarche. d5-TH2	65	116000065	Interruptor de flujo de agua
29	109070062	Panel trasero	66	136020083	Anillo de goma en la conexión de agua
30	103000331	Tubería	67	117110057	Sonda Tª salida de agua sensor d2-TH5
31	136020005	Bloque de goma	68	108010025	Clip
32	106000012	Manómetro	69	102041106	Intercambiador de calor de titanio
33	110000038	Conector del cable	70	133020006	Anillo de goma en conexión de agua
34	109070022	Parrilla trasera	71	133020012	Anillo de goma rojo
35	109070007	Tapa de caja electrica	72	102050004	Conjuntos de conexión de agua
36	117140019	Placa de controlador trifásica	73	117110053	Sonda Tªde entrada de agua. sensor d1-TH6
37	117260002	Tablero de filtro	74	133020011	Anillo de goma azul

**UX35Csi32T**

NO.	ERP	Part name	NO.	ERP	Part name
1	109070060	Tapa superior	38	109070006	Caja electrica
2	109070052	Panel de servicio	39	/	/
3	109070051	Marco superior	40	117010122	Módulo wifi
4	103000356	Evaporador	41	142000038	Relé
5	117230002	Reactor	42	117250022	PCB
6	109070019	Panel de ventilador	43	117240002	Anillo magnético
7	109070068	Panel de aislamiento	44	117240003	Anillo magnético
8	109070070	Panel izquierdo	45	115000006	Terminal de potencia
9	132000023	Aspa del ventilador	46	115000023	Terminal de potencia
10	108010024	Ensamblaje del motor del ventilador	47	136010004	Clip
11	112000031	Motor del ventilador	48	108960058	Caja de cableado
12	109070021	Soporte del motor del ventilador	49	113020636	Tubería
13	117110063	Sonda Tª ambiente d3-TH1	50	121000028	Válvula de 4 vías
14	133030020	Caja de control	51	113030183	Tubería
15	133460001	Panel frontal	52	116000068	Minipresostato de alta presion
16	117020293	Control	53	117110051	Sonda Tª descarga sensor d6-TH3
17	180060001	Bandeja de base	54	113020697	Tubería
18	109070069	Panel de servicio	55	/	Tubería
19	101000239	Compresor	56	113070061	Tubería
20	142000077	Resistencia de calentamiento del compresor	57	119000061	EEV
21	142000079	Resistencia de calentamiento del evaporador	58	113080116	Tubería
22	109070004	Placa de soporte del evaporador	59	120000066	Filtro deshidratador
23	109070066	Panel de servicio	60	113120053	Tubería
24	109070058	Panel derecho	61	113130039	Tubería
25	103000356	Tubería	62	113060214	Tubería
26	113190001	Alojamiento de sonda	63	116000073	Minipresostato de baja presión
27	113190007	Clip	64	105000015	Tanque de almacenamiento de líquidos
28	117110050	Sonda evaporador. Desescarche. d5-TH2	65	116000065	Interruptor de flujo de agua
29	109070062	Panel trasero	66	136020083	Anillo de goma en la conexión de agua
30	103000356	Tubería	67	117110057	Sonda Tª salida de agua sensor d2-TH5
31	136020005	Bloque de goma	68	108010025	Clip
32	106000012	Manómetro	69	102041106	Intercambiador de calor de titanio
33	110000038	Conector del cable	70	133020006	Anillo de goma en conexión de agua
34	109070022	Parrilla trasera	71	133020012	Anillo de goma rojo
35	109070007	Tapa de caja electrica	72	102050004	Conjuntos de conexión de agua
36	117140019	Placa de controlador trifásica	73	117110053	Sonda Tªde entrada de agua. sensor d1-TH6
37	117260002	Tablero de filtro	74	133020011	Anillo de goma azul

## Guide for Wi-Fi connection

### 1. INVERBOOST APP Download

Download “INVERBOOST” APP from GOOGLE PLAY or APP STORE with smart phone.

### 2. Connection

Make sure your smart phone is under 2.4 GHz/5 GHz wireless network signal and your INVERBOOST device is on to use “INVERBOOST” APP, and follow instruction as below.

1) Press “Add Device”, and scan below QR code to add your INVERBOOST device.

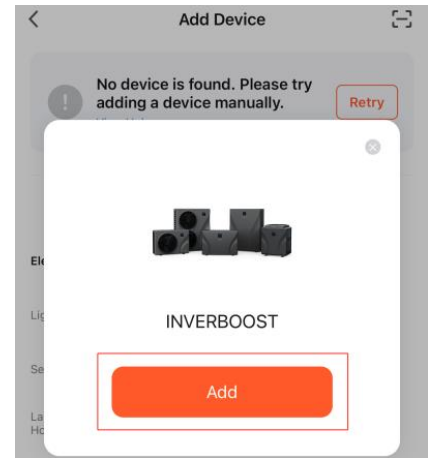
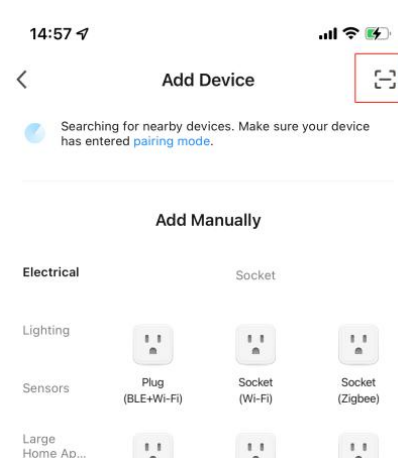
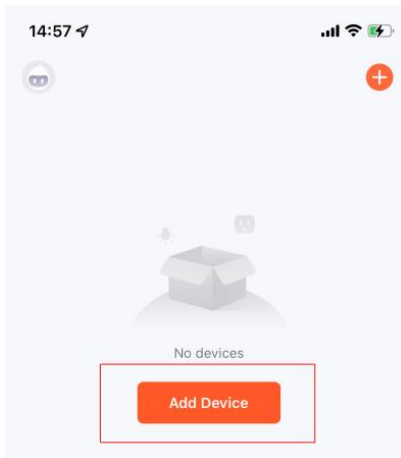

(INVERBOOST device QR code)



- 2) Select 2.4 Ghz/5 Ghz Wi-Fi Network and enter password. If your device is on, press "Next" directly, and no need to restart it.

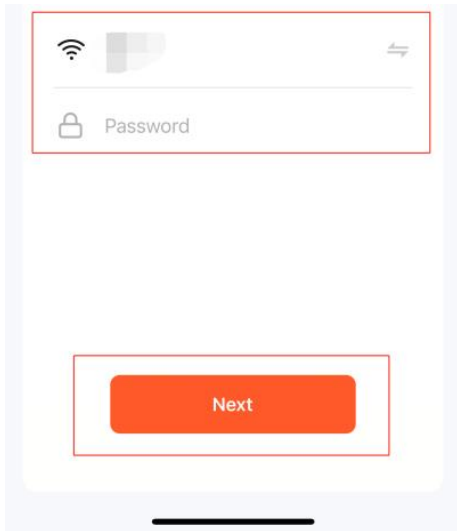

- 3) Keep pressing the on/off button of the machine controller for 5s.



- 4) Connection succeeded, and the name of the device could be modified.

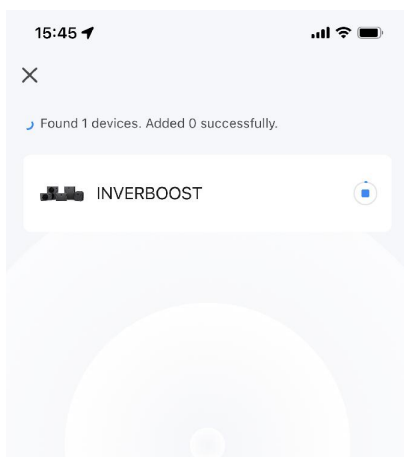

### 3. Function of INVERBOOST APP

#### 1) Connection share

Users who have successfully connected can freely share the link of the machine, so that other members can also control it through their mobile phone.

Use “Device Share” function and create a group to share the connection.

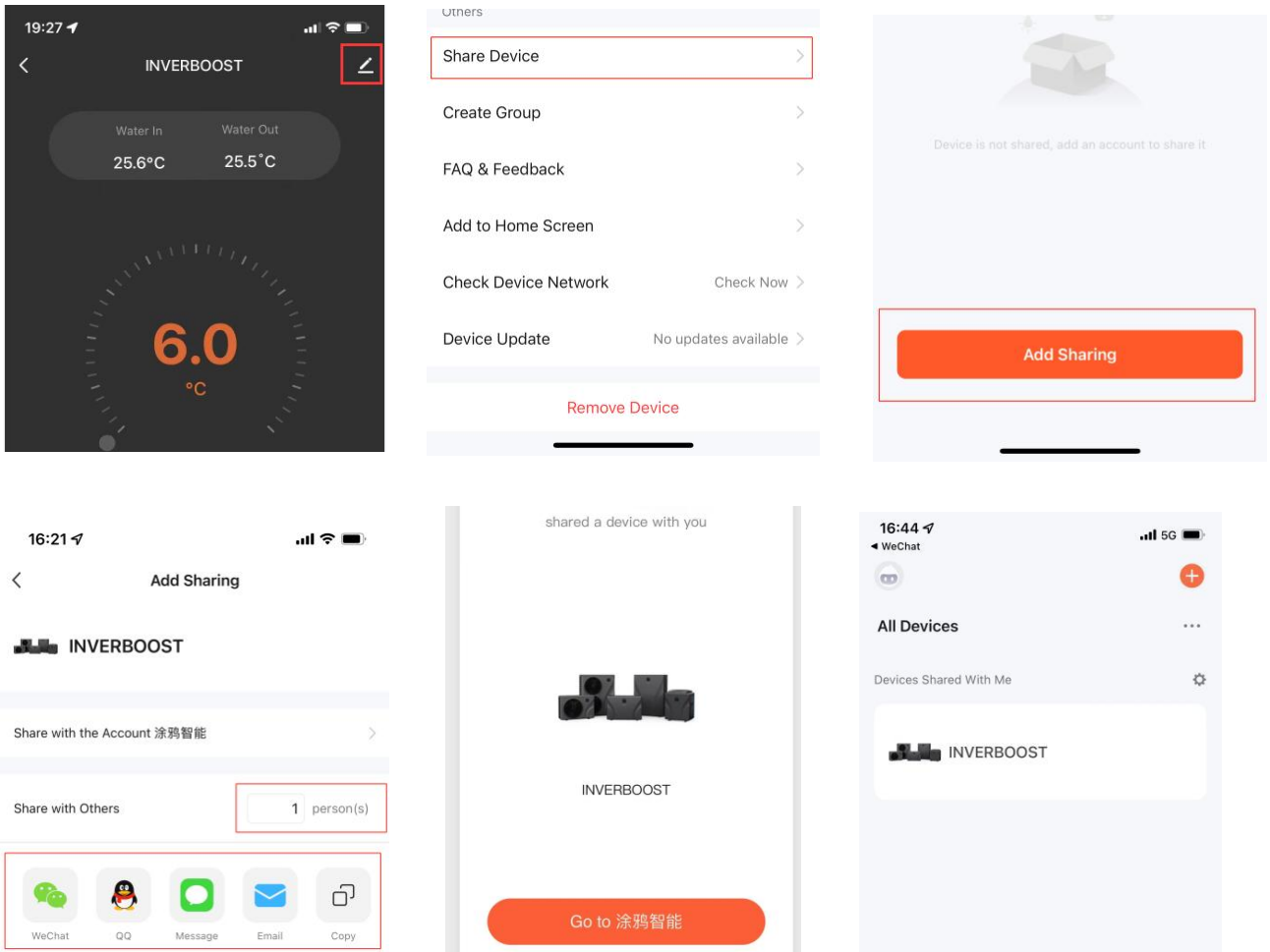

2) Operating mode, target temperature and work status control

A/ Changing operating mode by choosing “TURBO””SMART””SILENT”.

B/ Adjust the target temperature by dragging the right end of the temperature bar around the temperature dial. Temperature regulation accuracy is  $\pm 0.1^{\circ}\text{C}$ .

C/ Changing work status by choosing ”Heating””Auto””Cooling ”.

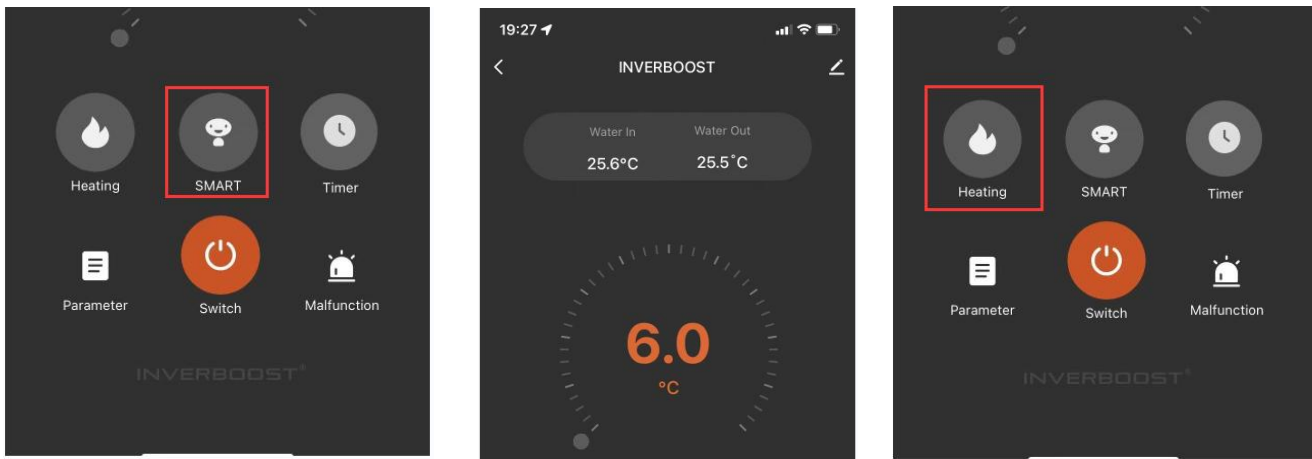

Mode	Temperature adjustment range	Temperature regulation accuracy
Heating	6-41°C	$\pm 0.1^{\circ}\text{C}$
Auto	6-41°C	$\pm 0.1^{\circ}\text{C}$
Cooling	6-35°C	$\pm 0.1^{\circ}\text{C}$

### 3) Timer setting

Through the timer function, the machine can be turned on or off at a specified time.

A/ And multiple sets of target times can be set at the same time.

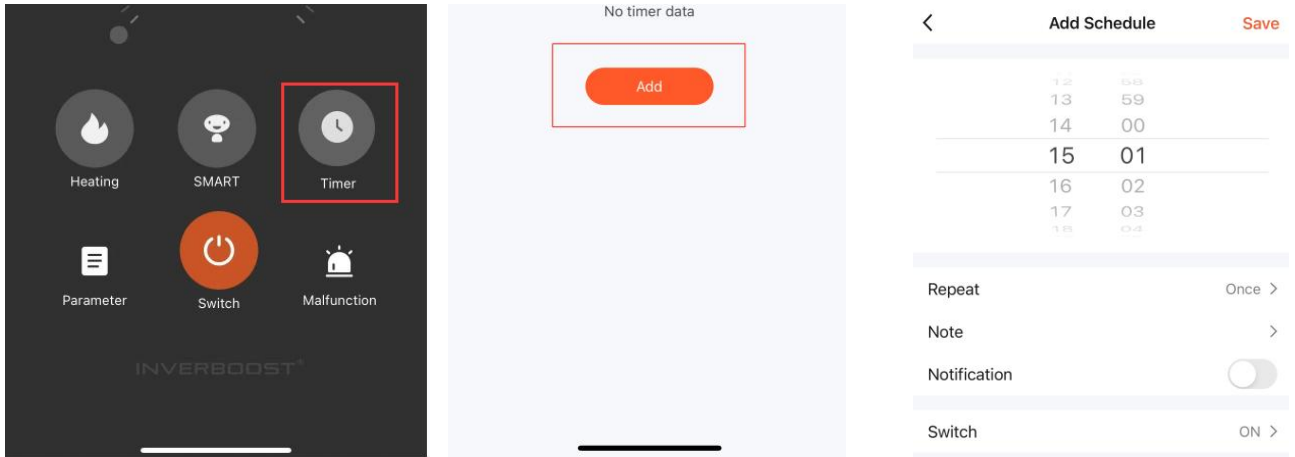

B/ INVERBOOST machine can be controlled on/off according to the specified day or a fixed period user set.

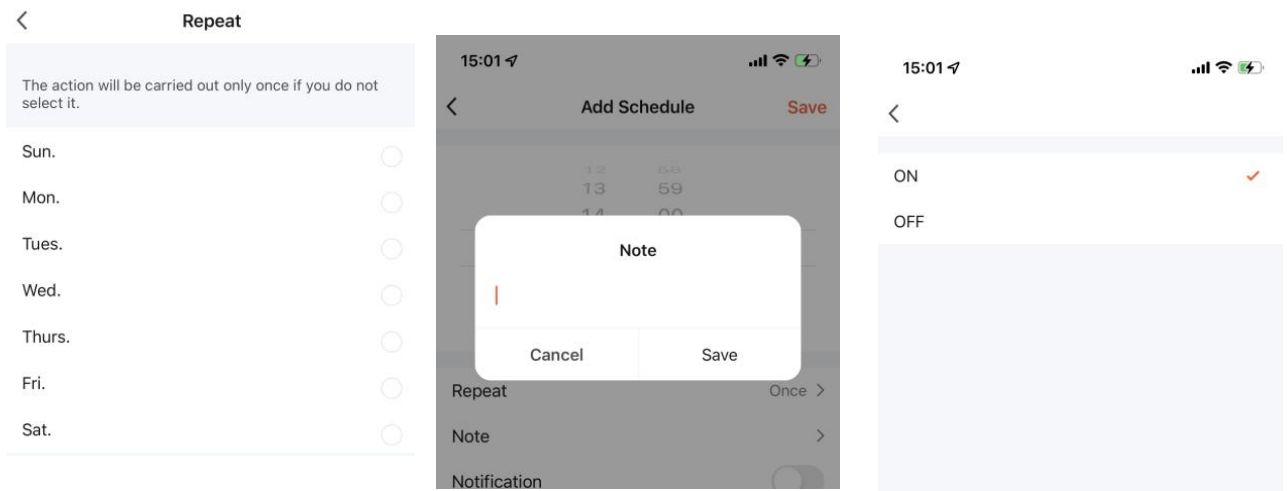

#### 4. Parameter and fault query

1) The real-time parameters of machine operation can be queried through the parameter interface.

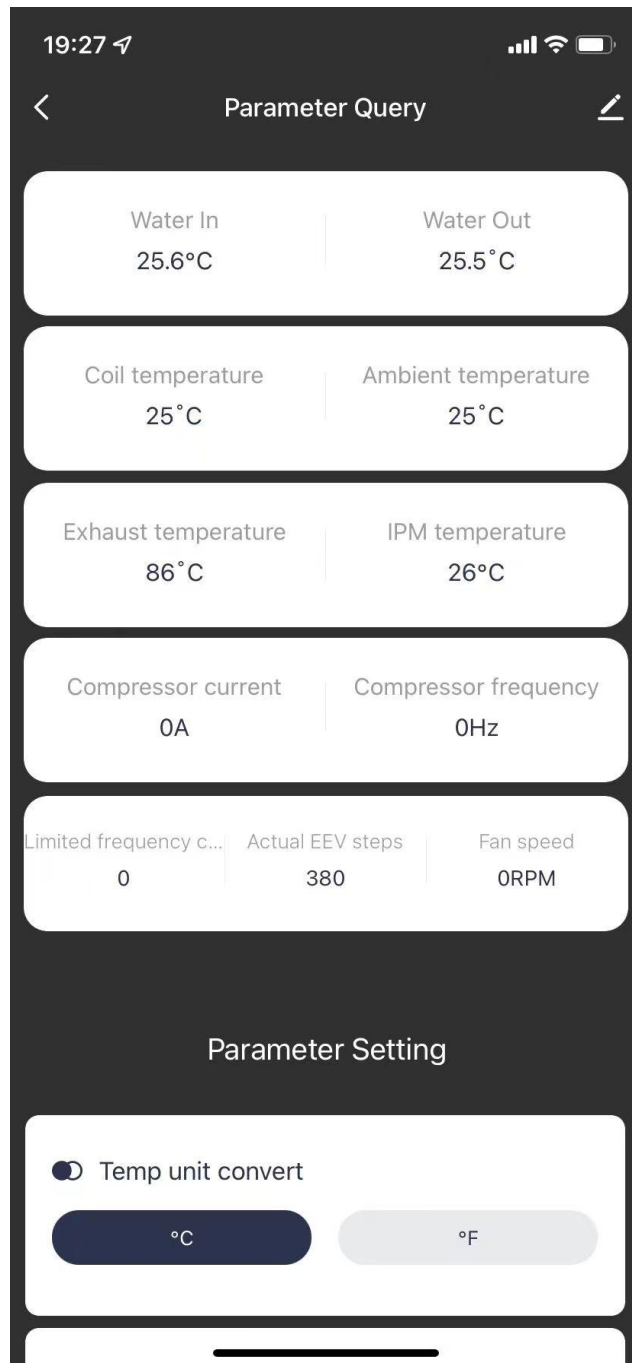

- 2) When the machine is not operating in a normal state, a pop-up window will appear on the interface to prompt the fault code. The fault code can be queried through "MALFUNCTION".

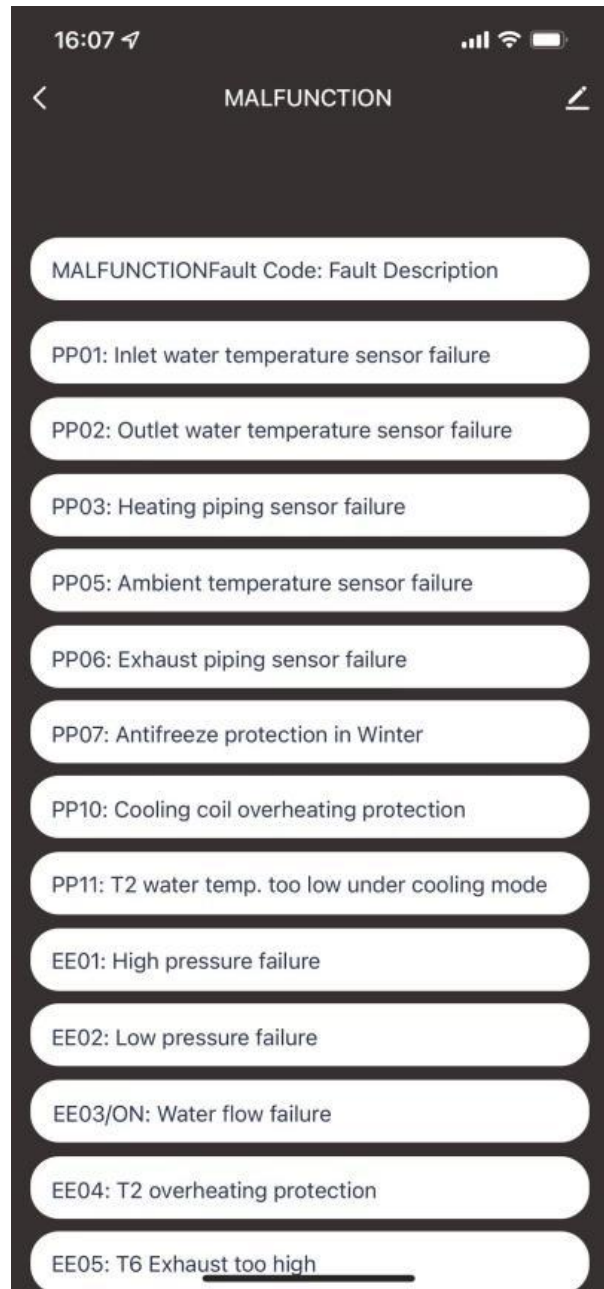
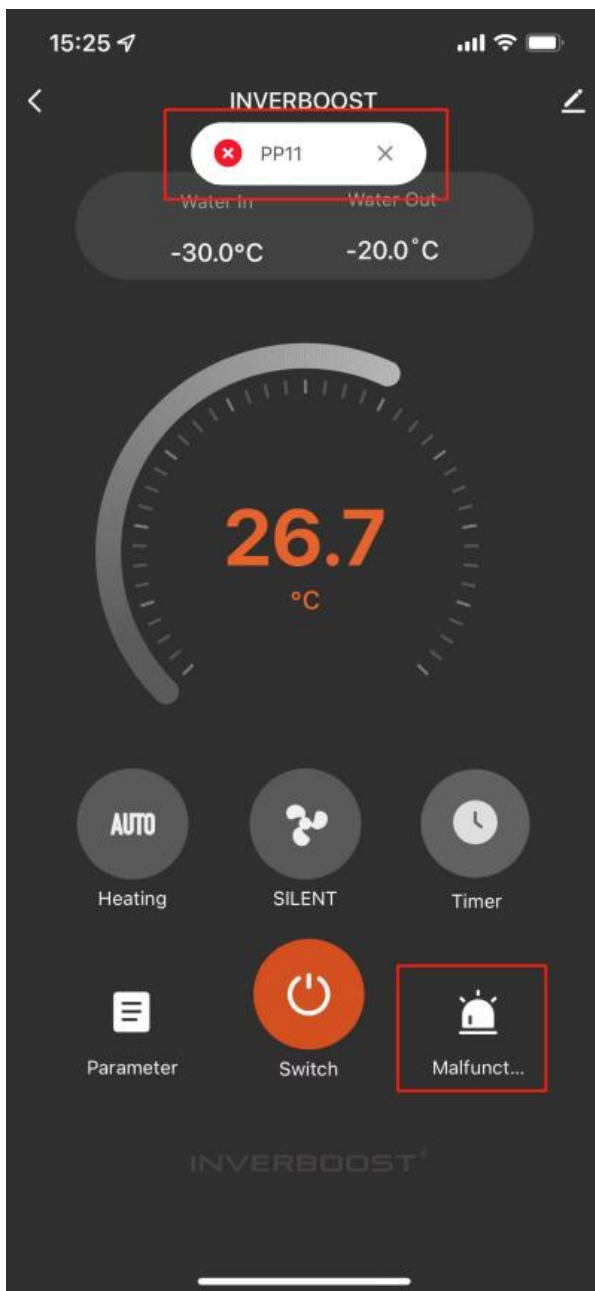



A0188UXI04